

How to Run a Lathe

The Care and Operation
of a Screw Cutting Lathe



No. 27
Revised Edition



WHEN interested in the purchase of a lathe write for a Catalog illustrating and describing the New and Improved line of South Bend Screw Cutting Lathes which are built in 210 sizes, types and patterns. This Catalog contains valuable data on lathes, tools and attachments and will be sent postpaid, no charge, to your address upon request.

How to Run a Lathe

Instructions on the Care and Operation of A Back Geared Screw Cutting Engine Lathe

For the Machinist Apprentice

REVISED
EDITION No. 27

Copyright, January, 1928
SOUTH BEND LATHE WORKS

Price 25 Cents Postpaid

Coin or Stamps of Any Country Accepted



Cable Address

"TWIN'S" SOUTH BEND, U. S. A.

SOUTH BEND LATHE WORKS

435 E. Madison Street

SOUTH BEND, INDIANA, U. S. A.

Printed in U. S. A.

PREFACE

ONE of the great needs of industry today is well trained workmen: men who are trained to work with their hands and also to think about their work, diagnose troubles and suggest improvements. No man can hope to succeed in any line of work unless he is willing to study it and increase his own ability in it.

It is the purpose of this book to aid the beginner or apprentice in the machine shop and the student in the school shop, to secure a better understanding of the fundamentals of the operation of a modern Screw Cutting Engine Lathe. In illustrating and describing the fundamental operations of modern lathe practice we have made an effort to show only the best and most practical methods and have tried to avoid tricks and freak methods so that the beginner may learn how to do his work properly.

We are indebted to so many manufacturers, engineers, authors, educators, mechanics and friends for assistance in the preparation of this book, that it would be impossible to give them individual mention here. However, we wish to express our appreciation for the co-operation that has made this work possible.

SOUTH BEND LATHE WORKS.



HOW TO RUN A LATHE, IN THE PORTUGUESE LANGUAGE

"How to Run a Lathe" has run into twenty-three editions in the Portuguese language. There are still some copies of this edition in stock and they may be had at ten cents per copy while they last.

HOW TO RUN A LATHE, IN THE SPANISH LANGUAGE

"How to Run a Lathe" is printed in the Spanish language and contains eighty pages. It has reached to twenty-second edition. We still have a small stock of these books and they may be had at ten cents per copy, postpaid.

HOW TO RUN A LATHE, IN CHINESE

The cut is from a photograph of the Chinese Version of "How to Run a Lathe," several thousand copies of which were printed in Shanghai. We supplied over 150 cuts and the translation was made by twenty-six engineers representing sixteen different countries. We cannot supply copies of this book as there are only a few in this country.

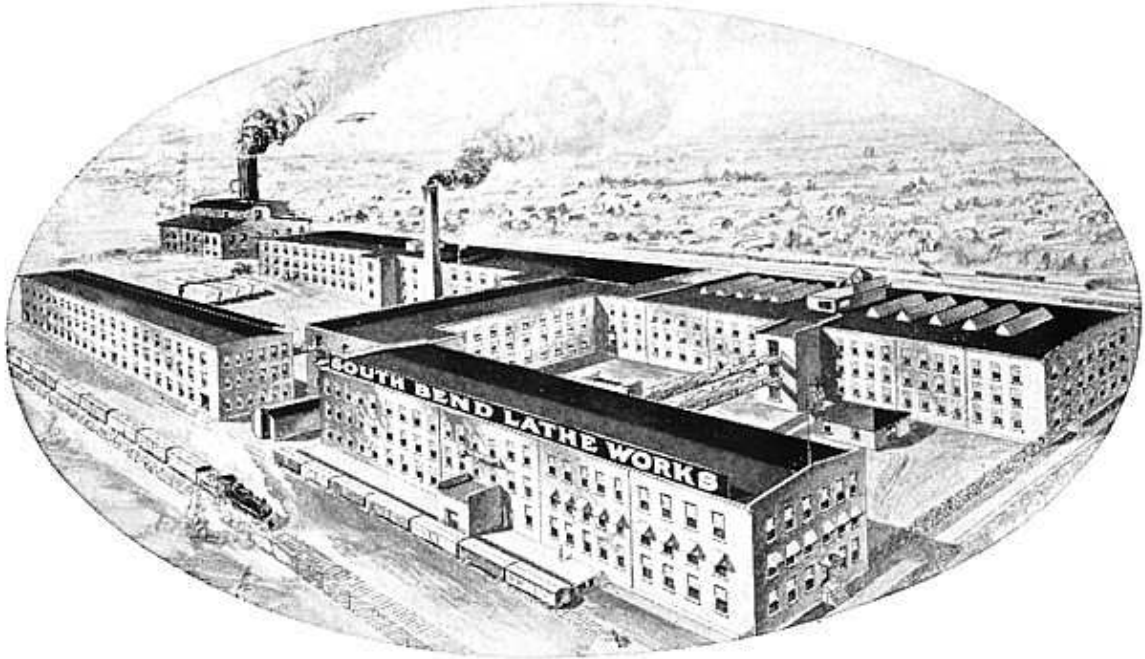

FACTORY OF THE SOUTH BEND LATHE WORKS
Established in 1906

Lathe Builders for Twenty-two Years

In 1906, more than 22 years ago, the South Bend Lathe Works was established in South Bend, Indiana. Since that time more than 40,000 South Bend Lathes have been built and are now in use in the United States and sixty-five foreign countries.

A halftone of the plant as it now appears is shown at the top of this page. The ground area covers four and one-half acres. The floor space area covers three and one-half acres. The equipment consists of the finest machinery that can be procured. Many of the machines were designed specially for the work of building lathes. Jigs and fixtures are used to insure accuracy and interchangeability of parts.

The business is devoted entirely to the manufacture of South Bend Lathes and the production capacity is normally about 4,000 lathes per annum. The production of lathes in such quantities makes it possible to sell at a reasonable price without sacrificing quality and at the same time insures the highest degree of accuracy because in quantity production accuracy is absolutely necessary.

With each South Bend Lathe a complete line of attachments can be supplied equipping it for the working of metals in the manufacturing plant, in the toolroom and in the machine shop, or in any shop where the most accurate work is desired.

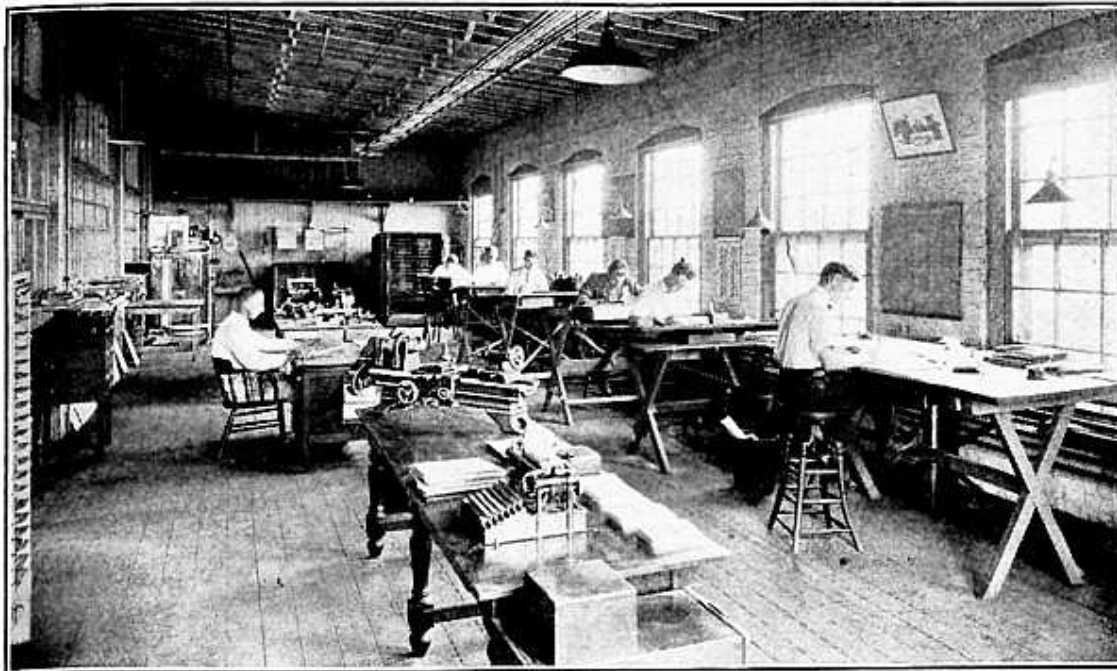

Engineering Department South Bend Lathe Works

NAMES OF THE PRINCIPAL PARTS OF THE LATHE

SOUTH BEND LATHE

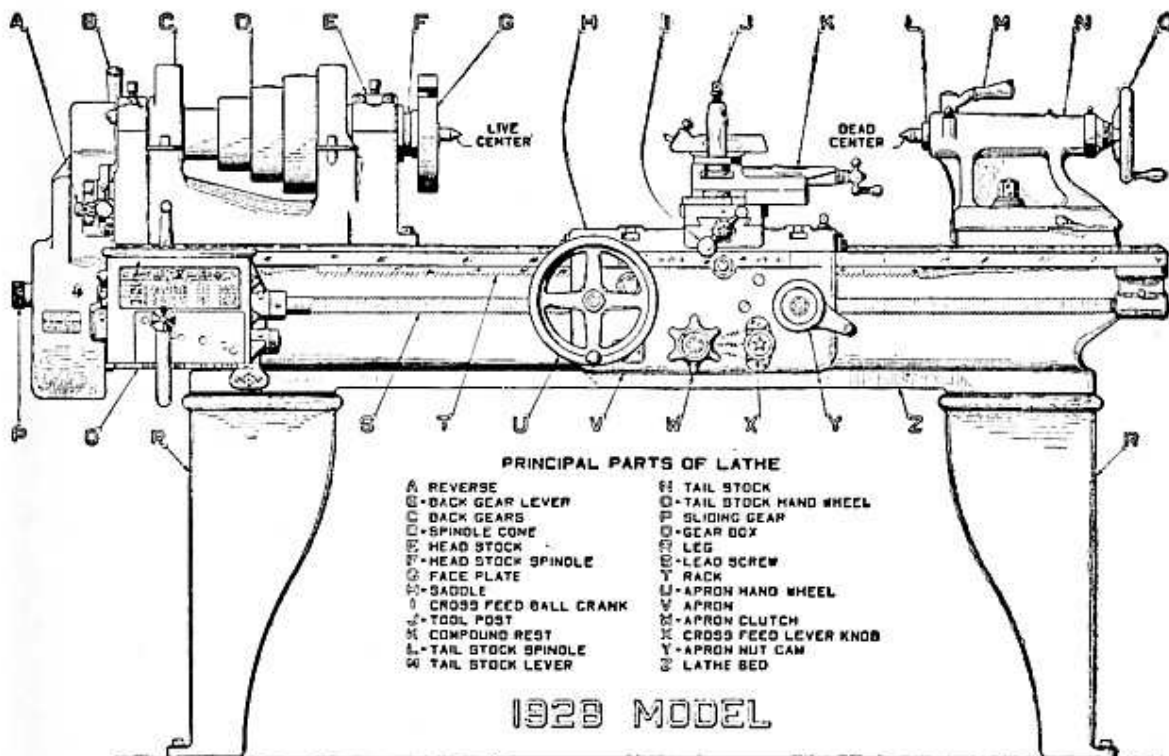

The above cut is taken from a large drawing 28"x40" which can be fastened to the wall for instruction purposes. A blue print of this drawing will be sent to any instructor or foreman postpaid on receipt of 25 cents.

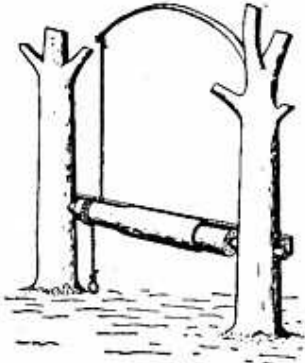

The Tree Lathe

THE TREE LATHE

The earliest style lathe of which we have record is called the tree lathe. It was simple in form as shown in the illustration, and is known to have been in use over two hundred years ago.

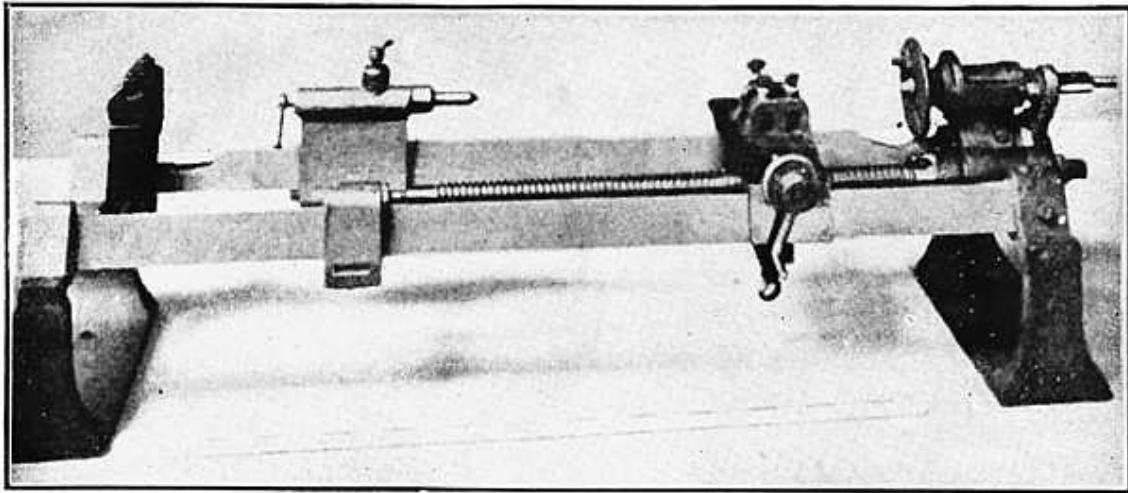

Maudslay Lathe

MAUDSLAY LATHE BUILT IN ENGLAND IN 1797

There was not much further development in lathes until 1797, when Henry Maudslay, an Englishman, designed and built a small screw cutting engine lathe. See illustration above. This lathe which is about a 10-inch swing, you will note is fitted with a Lead Screw, which is geared to the spindle. The slide rest or carriage is driven by the screw.

LATHES BUILT IN UNITED STATES

There were a few lathes built in the United States between 1800 and 1830, the beds being made of wood, with iron ways. In 1836 Putman of Fitchburg, Massachusetts, built a small lathe which was fitted with a Lead Screw.

THE SCREW CUTTING LATHE

The screw cutting engine lathe is the oldest, the first developed and most important of all the machine tools and from which were developed all other machine tools. This lathe is sometimes called the Universal Tool. It was the lathe that made possible the building of the steamboat, the locomotive, the electric motor, the automobile and all kinds of machinery used in industry. Without the lathe our great industrial progress would have been impossible.

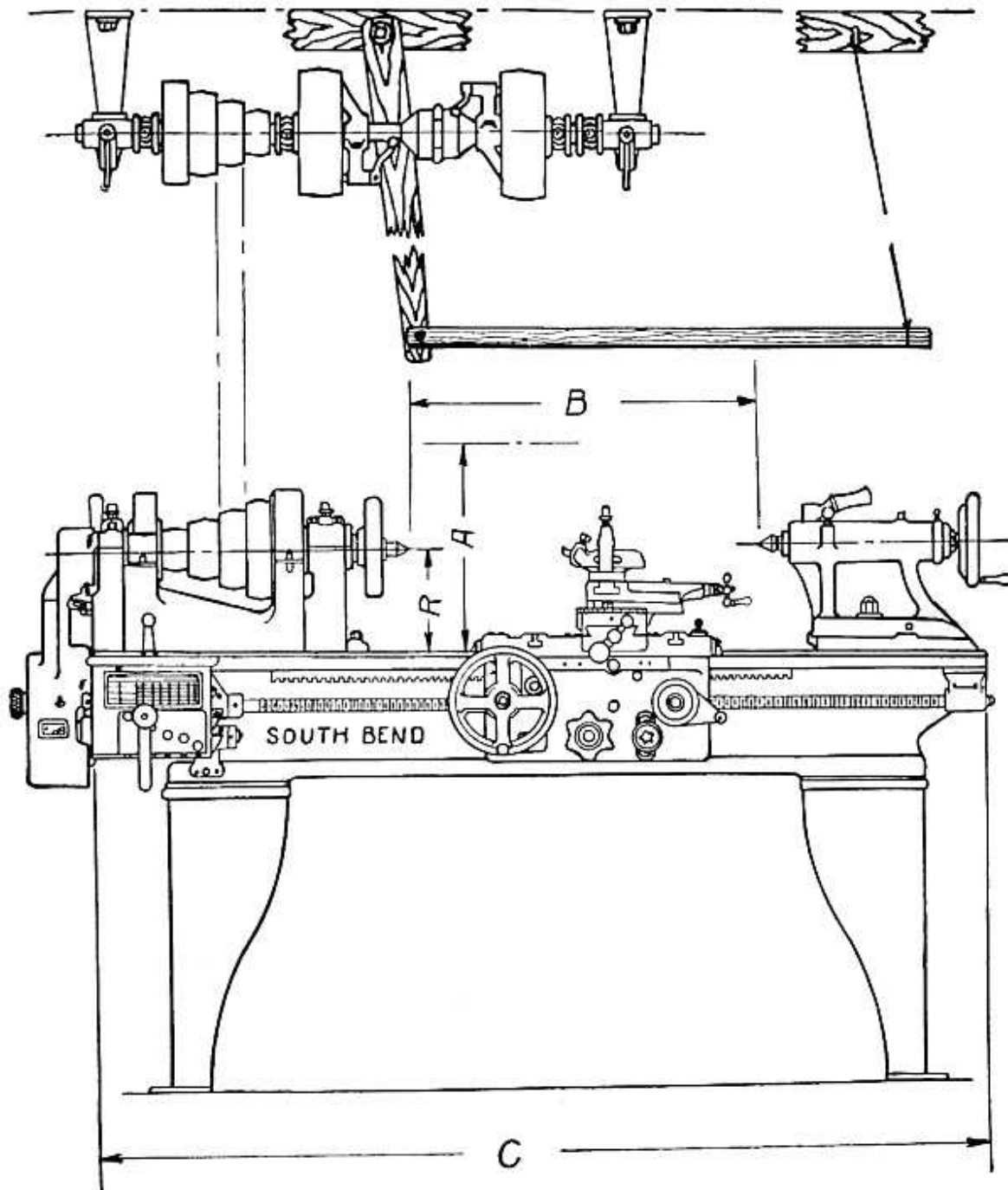

Fig. 400.—Size of Lathe

The size of a Screw Cutting Lathe is determined by the swing over bed and the length of bed. See drawing above.

- A represents the swing over bed.
- R represents the radius, one-half of the swing.
- C represents the length of bed.
- B represents the distance between centers when end of tail stock is flush with end of bed.

European tool manufacturers determine the size of a lathe by its radius or center distance; for example, an 8-inch center lathe is a lathe having a radius of 8 inches. What the European terms an 8-inch center lathe, the Americans call a 16-inch swing lathe.

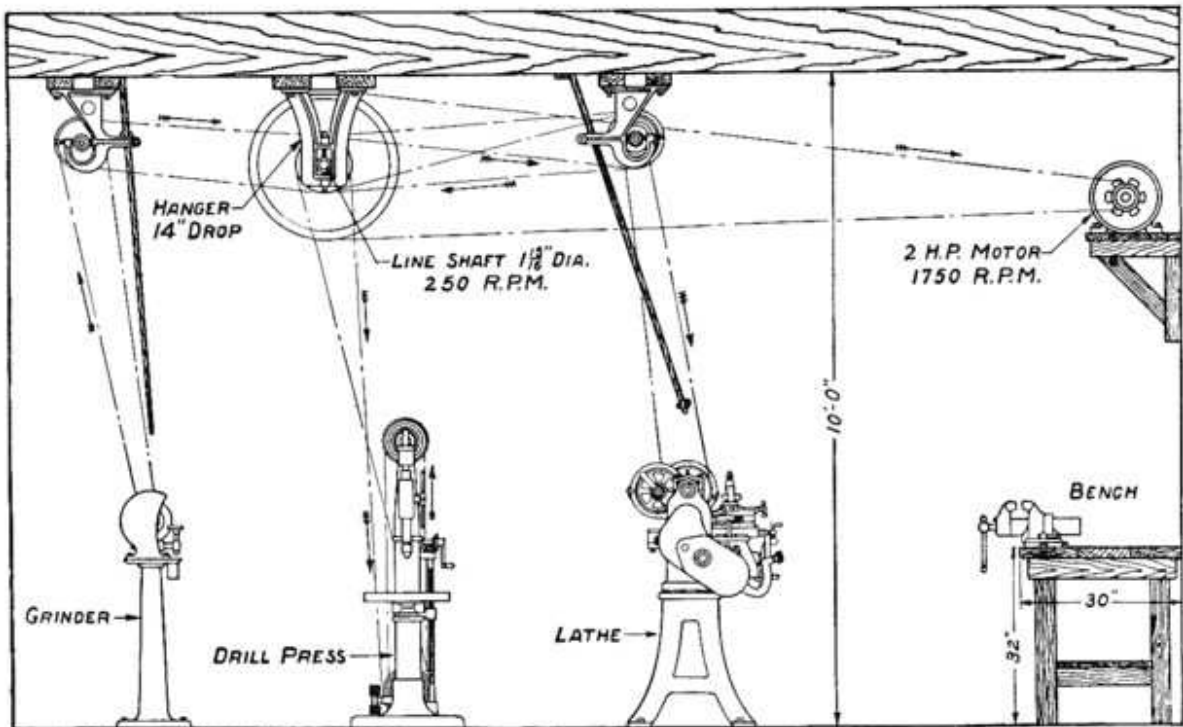

Fig. 401.—Layout of Small Machine Shop (end view)

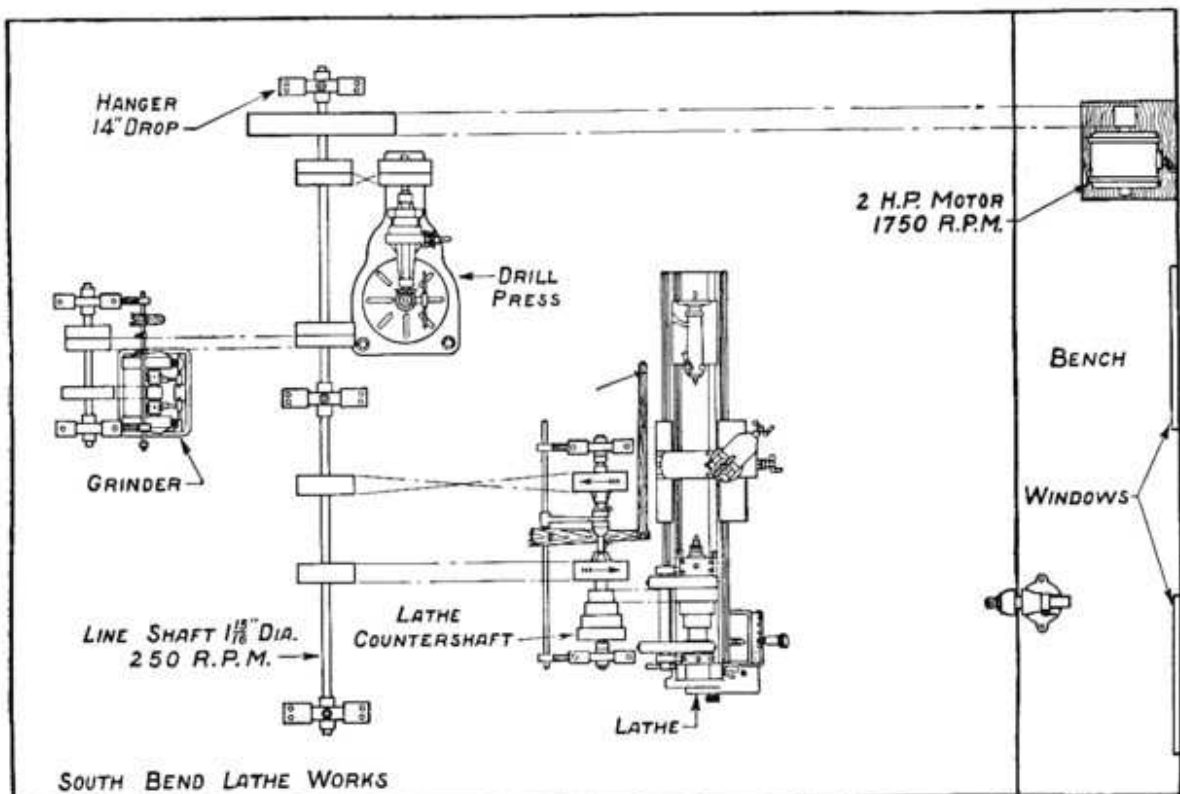

Fig. 402.—Layout of Small Machine Shop (plan view)

EQUIPMENT

The equipment consists of a 16" lathe, 20" Drill Press and 12" Emery Grinder.

The dimensions of this room as shown in the drawing are 20 feet

LAYOUT OF THE EQUIPMENT FOR A SMALL MACHINE SHOP

The Lineshaft.—The Lineshaft is $1\frac{1}{2}$ " in diameter, has a speed of 250 R. P. M., and is supported by three hangers, each 14" drop. The length of the lineshaft depends upon the length of the shop room. The distance between lineshaft hangers should not be more than 8'.

Style of Drive.—The lineshaft drive is recommended for small machine shops rather than individual electric motor drive for each machine. The reason is that with a lineshaft, one motor will serve and a number of machines may be driven from this lineshaft.

Pulleys.—Wood pulleys, crown face, are recommended on the lineshaft, except for the grinder and the drill press, and as both of these machines have shifting belts the pulleys on the lineshaft should be straight face.

The Motor.—The Motor is a 2 H. P., constant speed, 1750 R. P. M., set on a bracket on the side wall, high enough so that the belt will not interfere with the workmen passing underneath.

This motor has ample power to run the three machines in the equipment, all under load at the same time.

The Lathe.—The Lathe is set in a position where the light shines over the right shoulder of the operator. There is plenty of space between the operator and the bench. The lathe countershaft has the left belt straight and the right belt crossed to lineshaft. For instructions for erecting the Lathe, see Page 10.

The Drill Press.—The Drill Press is set almost under the lineshaft, and is driven by a cross belt direct from the lineshaft.

The Grinder.—The Grinder is set on the opposite side of the lineshaft, and is driven by its countershaft from the lineshaft.

The Bench.—The Bench is made of wood and is 30" wide and 32" high.

BLUE PRINTS

A blue print 12"x18" can be had of the layout on Page 8. If a different layout is required including other equipment, we will submit drawings on request, as we have a large number of layouts and foundation plans for machine shops of various types and sizes. We make no charge for this service.

THE AVERAGE SMALL SHOP

A lineshaft $1\frac{1}{2}$ " is used so that wood pulleys can be clamped to the shaft securely. A lineshaft smaller in diameter makes it difficult to fasten wood split pulleys.

The speed of the lineshaft is 250 R.P.M. which is the speed used in the industrial shop. 200 R.P.M. is satisfactory for the small repair shop.

LOCATING AND SETTING THE LATHE

The location of the lathe in the shop has much to do with its satisfactory operation. The lathe should be so located that it will not set closer than 18 inches to any other machine or wall. This will give room for making necessary adjustments. On the operator's side of the lathe, there should be at least 42 inches clearance, this gives the operator sufficient room to work, and also room for another person to pass back of the operator without interfering with his work.

The lathe should be located so that the light will shine over the operator's right shoulder, or so that his back will be toward the window.

The lathe should be set on a solid floor to keep down vibration. If necessary the floor should be braced to prevent its shaking. After the lathe has been set and leveled, it should then be securely fastened to the floor with lag screws.

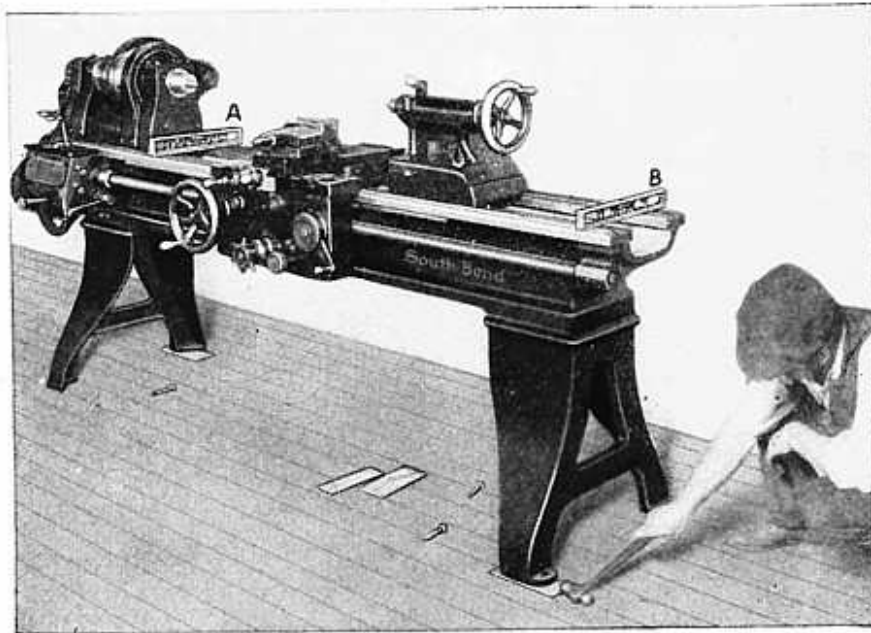

Fig. 403.—Leveling the Lathe

Fig. 403 shows the proper method of leveling a lathe. No lathe can do accurate work unless it is level and if at any time the machine is not doing accurate work, one of the first tests should be to see if it is setting level.

To level a lathe, place a level at least 18" long across the ways under the head stock center. See Fig. 403. If you have another level, place this across the ways at the tail stock end of the bed. Shim underneath the legs with shingles or thin strips of wood until the lathe is perfectly level.

Place the level lengthwise of the bed and test the bed on both the front and the back ways. If the lathe is not level in this direction shim up as before and again test with the level cross ways of the bed.

TO HANG THE COUNTERSHAFT

First: Place a plumb bob over the lineshaft in two different positions on the same side of the shaft about ten feet apart, to get a chalk line on the floor parallel to the lineshaft.

Second: Locate the lathe in the desired position parallel with the chalk line on the floor. Draw another line parallel with this lineshaft line about on center with the lathe bed under the head and tail spindles. Draw a third line 9" back of lathe center line, for the countershaft. These three lines should be parallel. Transfer the countershaft line to the ceiling by use of the plumb bob.

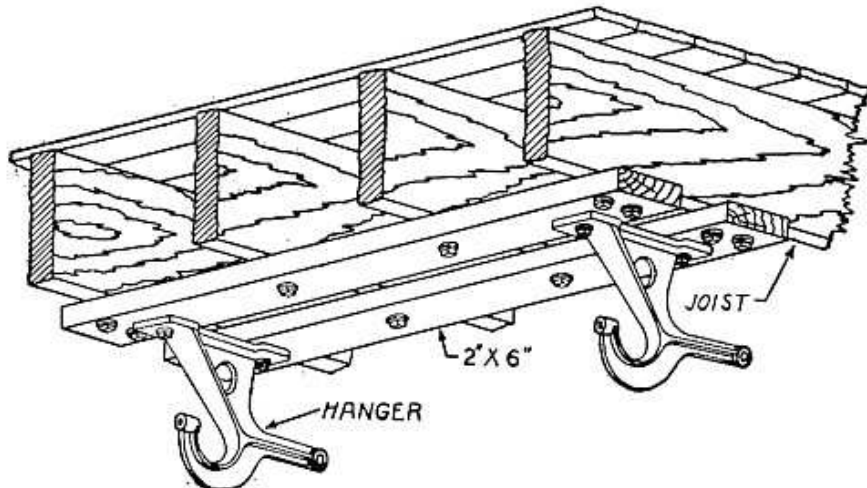

Fig. 404.—Attaching a Lathe Countershaft to Joists

Third: Bolt the countershaft hangers on the two 2x6s. Remove the shafting and pulleys. Fasten the 2x6s and hangers to the ceiling by lag bolts, as per illustration, to the joists so that the center line of the countershaft will be directly over and parallel to the countershaft center line as marked on the floor. It would be well to drill a small hole in the wood and put soap on the lag bolts, so they can be screwed in easily.

After the 2x6s are fastened to the ceiling, replace the countershaft in its hanger. The hangers are provided with longitudinal holes for adjustment. Adjust the hangers so that the countershaft will be parallel with the lineshaft. At the same time level the lineshaft. Fasten hangers securely to the 2x6s. See that shaft revolves freely, and that the set screws that hold the boxes are tight, and also fasten the jam nuts on the set screws. Note carefully the two collars inside the boxes. These collars should be fastened securely as they prevent end play of the countershaft. After these collars are fastened, try again and see that the countershaft revolves freely.

Specifications of Countershafts for South Bend Lathes

Size of Lathe	Size of C.S. Friction Pulley	Speed of Countershaft	Size of Lathe	Size of C.S. Friction Pulley	Speed of Countershaft
9 in.	6 $\frac{7}{8}$ x 2 $\frac{3}{16}$ in.	290 R.P.M.	16 in.	10 x 3 $\frac{5}{8}$ in.	225 R.P.M.
11 in.	6 $\frac{7}{8}$ x 2 $\frac{3}{16}$ in.	290 R.P.M.	18 in.	12 x 4 $\frac{1}{2}$ in.	200 R.P.M.
13 in.	8 x 2 $\frac{3}{8}$ in.	275 R.P.M.	21 in.	12 x 4 $\frac{1}{2}$ in.	175 R.P.M.
15 in.	10 x 3 $\frac{5}{8}$ in.	250 R.P.M.	24 in.	14 x 5 in.	150 R.P.M.

RULES FOR CALCULATING THE SPEED AND SIZE OF PULLEYS

The driving pulley is called the driver and the driven pulley is the driven or follower.

R. P. M. indicates the number of revolutions per minute.

Problem 1.—The revolutions of driver and driven, and the diameter of the driven being given, required the diameter of the driver.

RULE.—Multiply the diameter of the driven by its number of revolutions, and divide by the number of revolutions of the driver.

Problem 2.—The diameter and revolutions of the driver being given, required the diameter of the driven to make a given number of revolutions in the same time.

RULE.—Multiply the diameter of the driver by its number of revolutions, and divide the product by the given number of revolutions of the driven.

Problem 3.—The diameter and number of revolutions of the driver, with the diameter of the driven, being given, required the revolutions of the driven.

RULE.—Multiply the diameter of the driver by its number of revolutions, and divide by the diameter of the driven.

Problem 4.—The diameter of the driver and driven, and the number of revolutions of the driven, being given, required the number of revolutions of the driver.

RULE.—Multiply the diameter of the driven by its number of revolutions, and divide by the diameter of the driver.

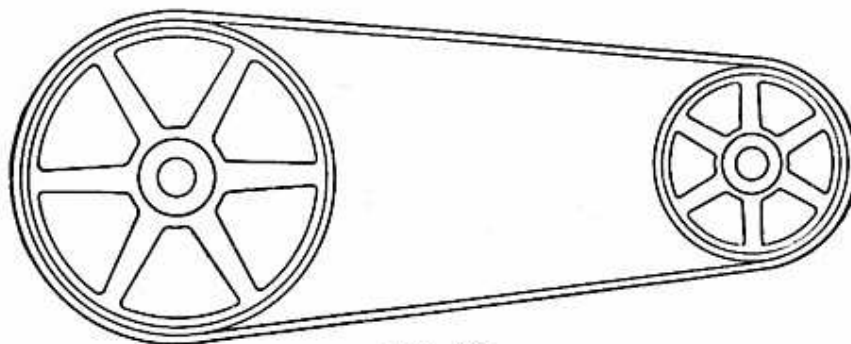

Fig. 405

One of the pulleys is the driver, the other is the driven.

Example: Problem 1.

Given: Speed of the driving pulley 260 R.P.M. Speed of the driven pulley 390 R.P.M. Diameter of the driven pulley 8".

To Find the diameter of the driving pulley.

$$\begin{aligned} 390 \times 8 &= 3120 \\ 3120 \div 260 &= 12'' \end{aligned}$$

The diameter of the driving pulley is 12".

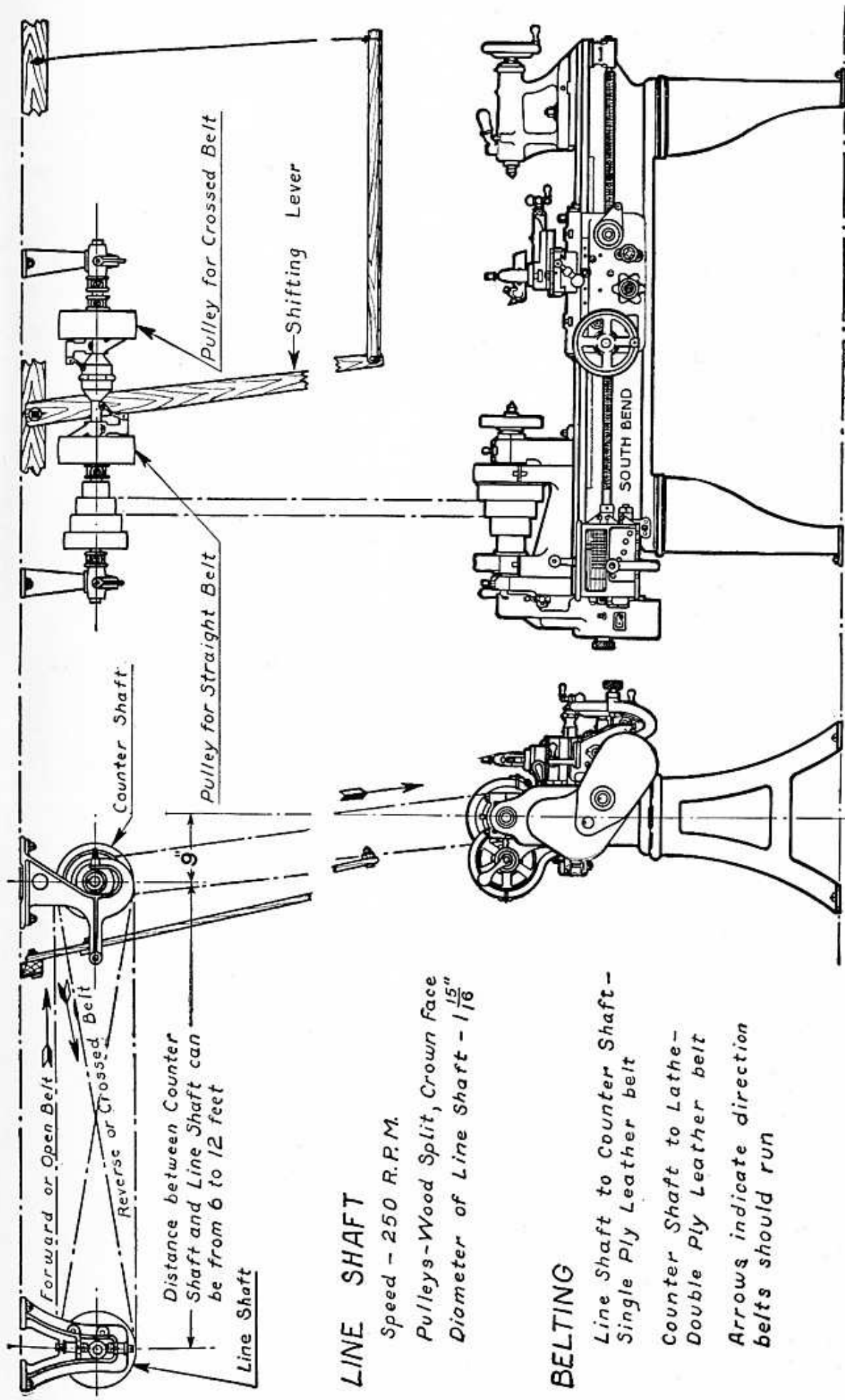

LINE SHAFT

Speed - 250 R.P.M.
 Pulleys - Wood Split, Crown Face
 Diameter of Line Shaft - $1\frac{15}{16}$ "

BELTING

Line Shaft to Counter Shaft -
 Single Ply Leather belt
 Counter Shaft to Lathe -
 Double Ply Leather belt
 Arrows indicate direction
 belts should run

Fig. 406.—Setting Up of the Lathe

LACING A LEATHER BELT

A leather belt should have the smooth or grain side running next to the pulley, because the smooth surface of the belt eliminates air pockets between the belt and the pulleys, and belt slipping is reduced to a minimum.

In measuring for the length of belt needed, place a steel tape or a strong cord over the pulleys that the belt is to run on. Draw taut and read the measurement on the tape, or cut the cord at the proper place.

Straighten the belt out on the floor and measure it with the cord or tape, drawing the cord as taut as you did when measuring over the pulleys. Mark the length of the belt with a square and cut off evenly.

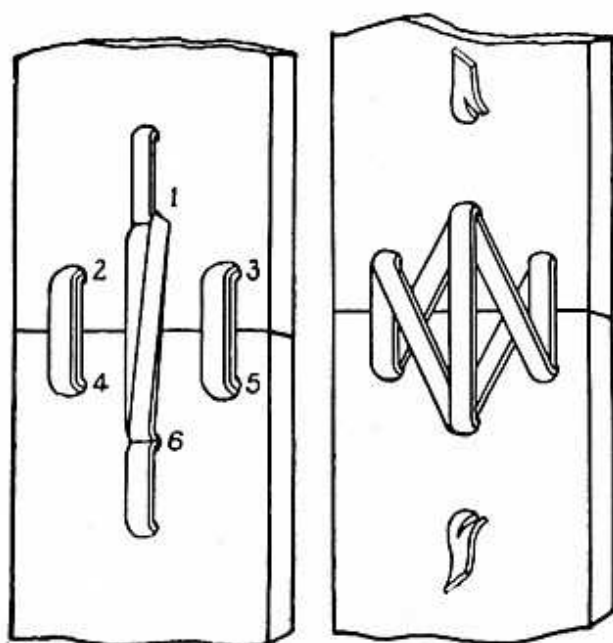

Fig. 407

Fig. 408

Fig. 407.—Smooth Side of Belting

Fig. 407 shows the smooth or grain side of a 3-inch leather belt that has been laced. The lacing is not crossed on this side.

Fig. 408.—Rough Side of Belting

Fig. 408 shows the outer or rough side of the same belt. The lacing has been crossed on this side of the belt.

The holes for the rawhide or leather lacing should be punched a sufficient distance from the edge in order not to weaken the belt. These holes should be just large enough to permit the lacing to be pulled through.

Fig. 407. Start lacing the belt on the smooth side by placing one end of the lace through hole No. 1, the other end through hole No. 6. Pull tight and even up at ends of the lacing. Lace alternately in the following order:

- From No. 6 to No. 2, and from No. 1 to No. 5.
- From No. 5 to No. 3, and from No. 2 to No. 4.
- From No. 4 to No. 2, and from No. 3 to No. 5.
- From No. 5 to No. 3, and from No. 2 to No. 4.
- From No. 4 to No. 1, and out and from No. 3 to No. 6.
- From No. 6 to No. 1, and from No. 1 to No. 6 and out.

In lacing wider belts, the same plan can be used as shown in above drawing. For example, a 5-inch belt requires 5 holes on the edge where the belt meets.

SHIFTING A BELT

The belt running between the countershaft and the lathe spindle should be leather, double ply, and laced with rawhide lacing.

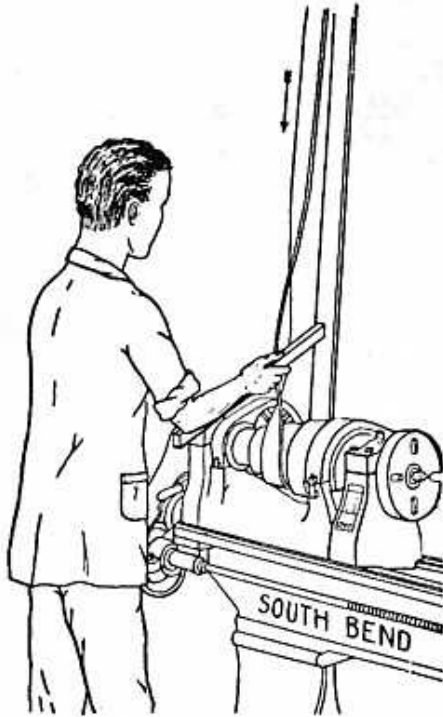

Fig. 409.—Shifting Belt on Lathe

Fig. 409 shows the method of shifting the belt on the spindle cone while the lathe is running. With a stick in his right hand, the operator pushes the belt from one cone step to another, keeping a firm hold on the stick.

To shift the belt on the countershaft cone to a larger step, the operator uses a long belt stick with an iron pin in the end, as shown in Fig. 410. While the countershaft is revolving, give the belt a sharp push and twist with the pin on the end of the stick.

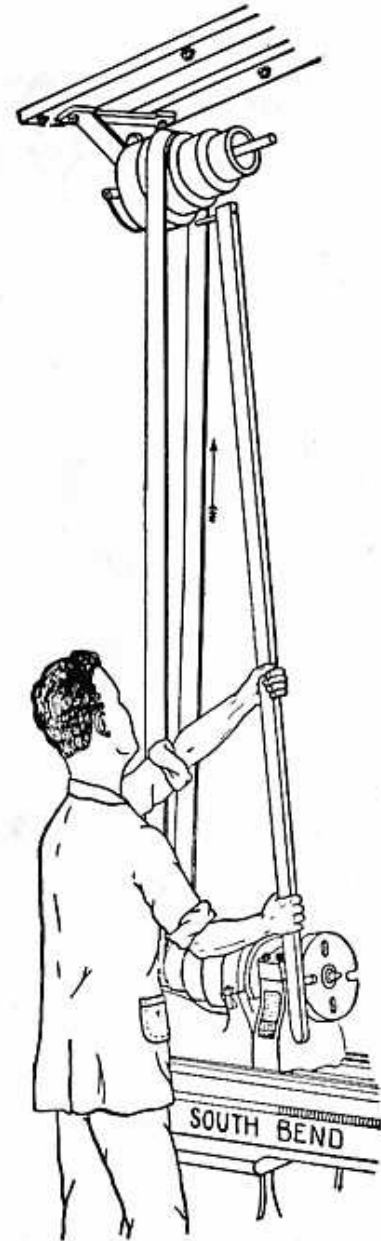

Fig. 410.—Shifting Belt on Countershaft

For the beginner, we recommend when shifting belts, he stop the lathe and shift by hand by pulling the belt, and slipping one side off of the larger step cone, then complete the shift to the desired position, and again turn by hand to run the belt in the proper position.

After a little experience of shifting by hand, he will learn how to shift the belt while the lathe is running.

OILING THE LATHE

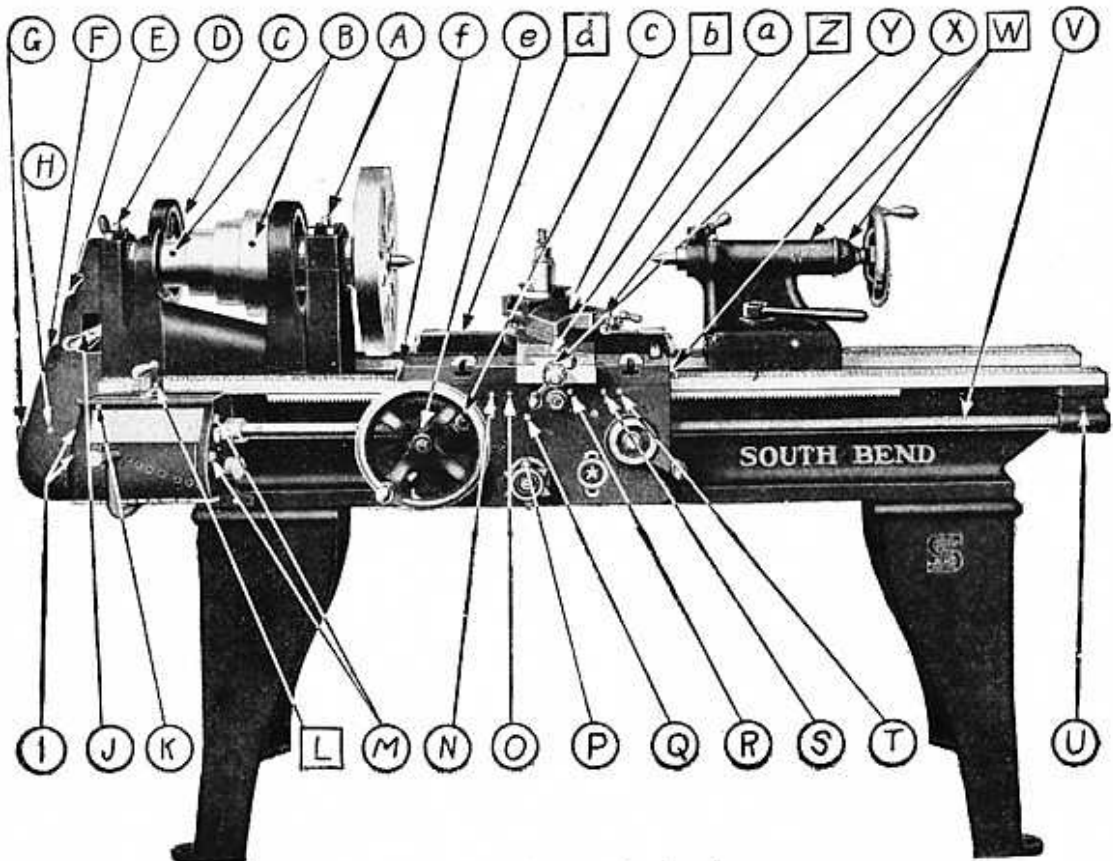

Fig. 411.—Oiling the Lathe

Fig. 411 shows a photograph of the lathe with the principal oil holes indicated by arrows. There is a symbol at the end of each arrow showing how frequently each bearing should be oiled. Start with oil hole marked "A" and follow through in regular order, B, C, D, etc.

Key to Symbols

- O indicates bearings that are to be oiled daily.
 □ indicates bearings that are to be oiled weekly.

- | | |
|--------------------------------|--------------------------------------|
| A—Spindle Bearing (Large) | R—Apron Cross Feed Gear Bearing |
| B—Cone Bearings | S—Apron Worm Support Bracket |
| C—Back Gear Quill Bearings | T—Lead Screw Half Nut |
| D—Spindle Bearing (Small) | U—Lead Screw Bearing (Right End) |
| E—Reverse Twin Gears Bearing | V—Lead Screw Thread |
| F—Primary Gear Bearing | W—Tail Stock Barrel and Nut Bearings |
| G—Primary Sliding Gear Bearing | X—Saddle Bearings (Four) |
| H—Primary Drive Gear Bearing | Y—Cross Feed Bushing |
| I—Gear Box Shaft Bearings | Z—Compound Rest Bushing |
| J—Reverse Lever Bearing | a—Cross Feed Screw Bearing |
| K—Gear Box Bearings | b—Compound Rest Screw Threads |
| L—Quick Change Lever | c—Apron Rack Pinion Bearing |
| M—Gear Box Shaft Bearings | d—Saddle Gib Surface Bearing |
| N—Apron Worm Bracket Bearing | e—Apron Hand Wheel Bearing |
| O—Apron Worm | f—Saddle Bearings (Four) |
| P—Friction Feed Clutch Bearing | |
| Q—Apron Idler Gear Bearing | |

OILING THE LATHE

Keeping the lathe well oiled has much to do with the life of the lathe and the quality of the work it will turn out. Follow these directions carefully if you wish to keep your lathe in first class condition.

First.—Use only a good grade of machine oil, equal in quality to Atlantic Red, in oiling the lathe. Oil all bearings regularly as directed in Fig. 411.

Second.—Always oil in the order indicated so that no holes will be missed. If you do this you will soon form the habit and the oiling will require only a very short time.

Third.—Do not use an excess of oil. A few drops is sufficient and if more is applied, it will only run out of the bearings and get on the machine, making it necessary for you to clean the machine more frequently.

Fourth.—After you have completed the process of oiling the lathe and countershaft wipe off the excess oil around the bearings with a clean cloth or waste.

Fifth.—Take pride in keeping the lathe clean and neat. You will do better work on a clean machine than a dirty one. If compressed air is available, use this occasionally to blow off all dirt and refuse.

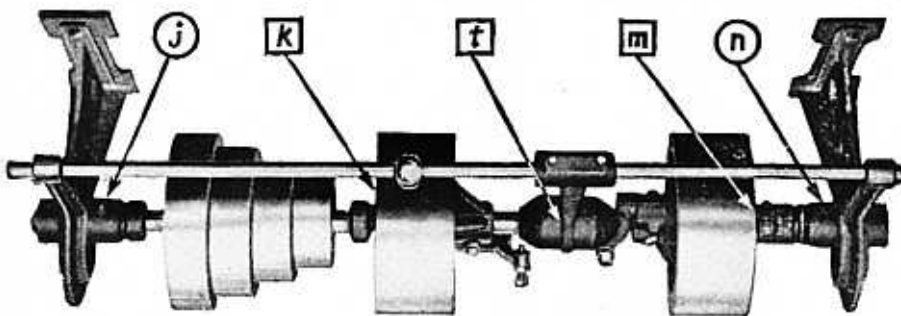

Fig. 412.—Oiling the Countershaft

Fig. 412 shows a photograph of the countershaft with the principal oil holes indicated by arrows. There is a symbol at the end of each arrow showing how frequently each bearing should be oiled. Oil the countershaft as regularly as the lathe itself. The fact that the countershaft is not as easy to get to as the lathe, is no excuse for slighting it.

Key to Symbols

- Indicates bearings that are to be oiled daily.
- Indicates bearings that are to be oiled weekly.

- j—Countershaft Bearing.
- k—Grease Cup Friction Clutch Pulley.
- t—Countershaft Yoke Lever and Yoke Cone.
- m—Grease Cup Friction Clutch Pulley.
- n—Countershaft Bearing.

Neither the lathe nor the countershaft should be oiled while the machine is in motion.

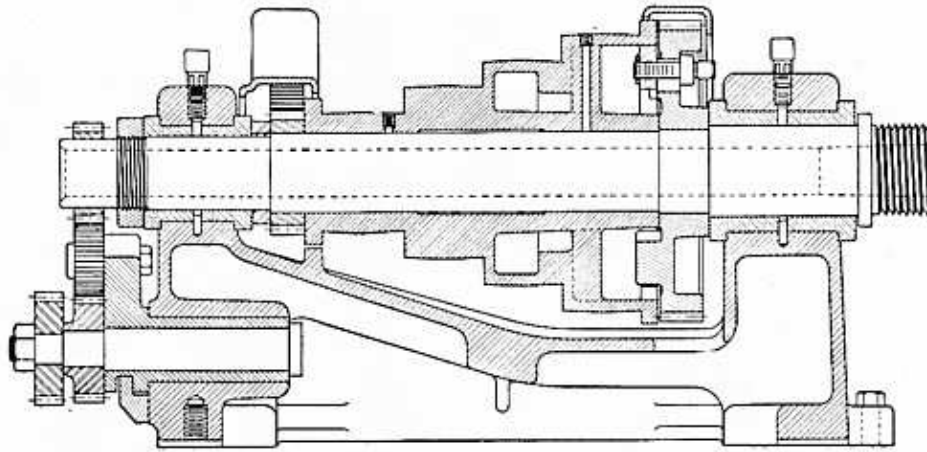

Cross Section of a Lathe Head Stock

The principal parts of the head stock of the New South Bend Lathe are shown in the above drawing. They are: the Steel Spindle, Bronze Bearings, Spindle Cone, Back Gears, Reverse Gears, Take-up Nut, Thrust Collar and Head Stock Frame.

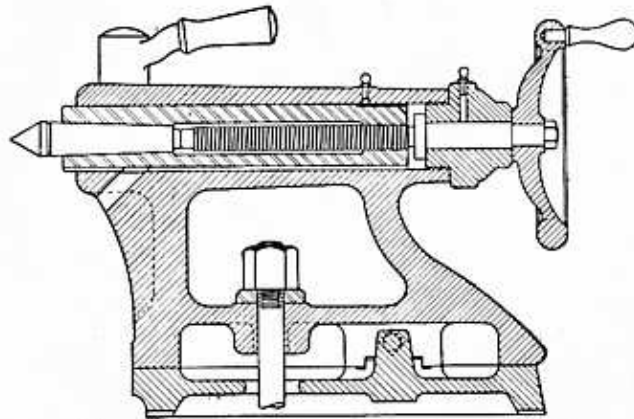

Cross Section of a Lathe Tail Stock

The Tail Stock of the New South Bend Lathe is shown above. The principal parts are, the Steel Spindle, Spindle Adjusting Screw, Barrel Nut, Spindle Binding Clamp, Tail Spindle Center, Bolt for Clamping Tail Stock to Bed, Tail Stock Top, and Tail Stock Bottom.

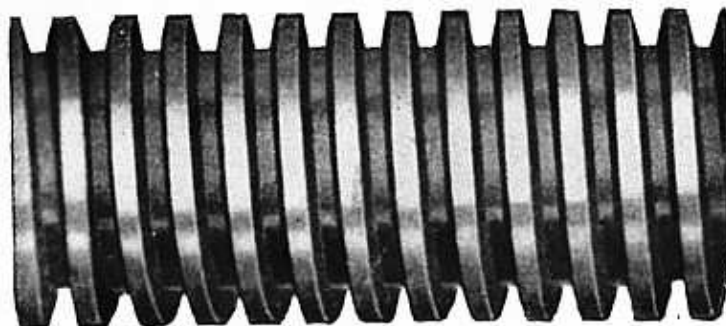

The Lead Screw of the Lathe

The illustration shows a section of the lead screw of the New South Bend Lathe. These lead screws are made of a special steel, have a coarse pitch Acme thread and are cut with precision accuracy, on a special machine equipped with a master lead screw which permits the finest precision thread gauges, taps, etc., to meet the most exacting requirements.



HAND SCRAPING THE WAYS OF A LATHE BED

After a lathe bed has been machined it is thoroughly seasoned, then finish planed. Extreme accuracy is obtained by scraping the ways by hand, so all South Bend Lathe Beds are hand finished and frosted by master craftsmen preparatory to the fitting of the carriage, headstock and tailstock.

FITTING THE BRONZE SPINDLE BEARINGS

The Bronze Bearings for the spindle are machined all over and are hand fitted to the housings of the headstock. The spindle being finished ground, is placed in the bronze bearings and turned by hand. The prussian blue on the spindle will mark the high points of the bronze bearings for hand scraping. The scraping of these bearings to a perfect fit requires great skill.

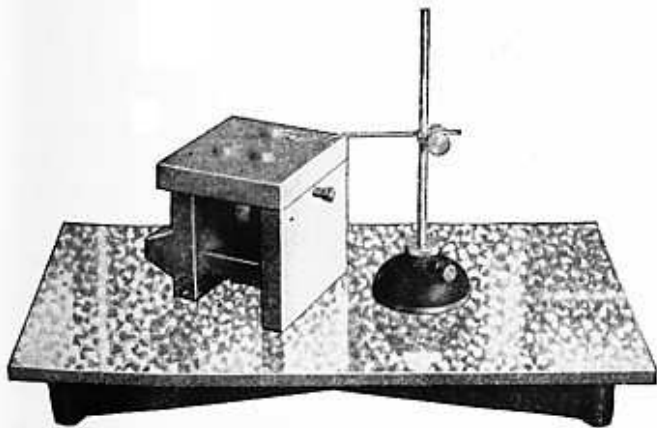
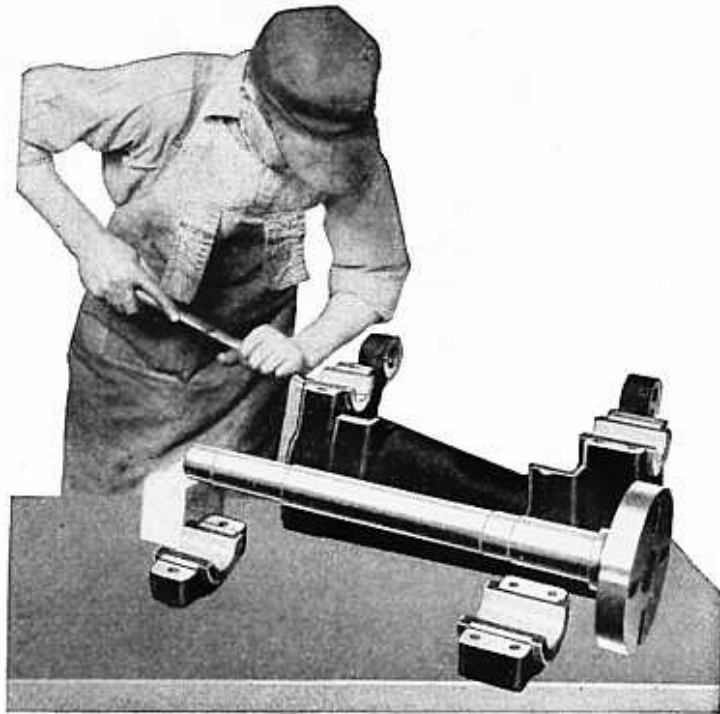

HAND SCRAPING ON MACHINE PARTS

The accuracy and precision of a fine piece of machinery depends upon the fit of the bearings. Sliding surfaces must be hand scraped and also the important cylindrical bearings.

The surface plate, shown in the illustration, is used in the building of fine machinery to test plane surfaces while hand scraping. Two surface plates are necessary so that they may be tested together occasionally and the surface kept perfectly true and flat.

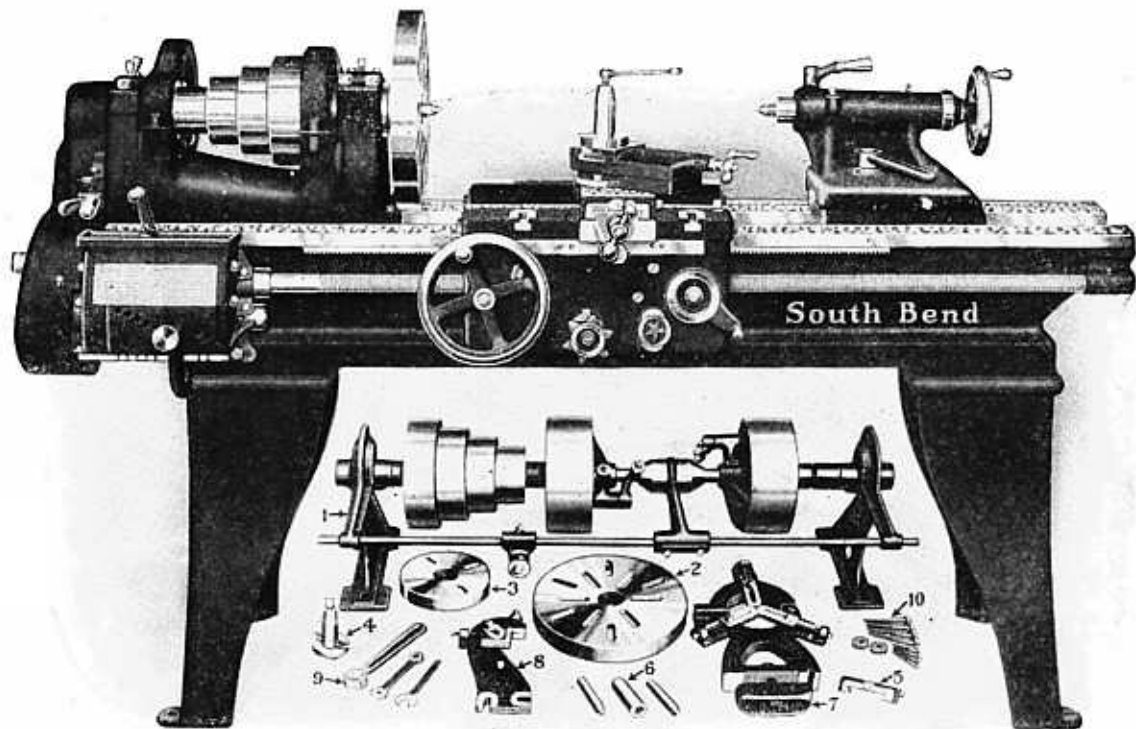

THE NEW MODEL BACK GEARED QUICK CHANGE SCREW CUTTING LATHE WITH OVERHEAD COUNTERSHAFT DRIVE

The new model back geared quick change screw cutting lathe, illustrated above, has a multitude of uses. It has the power for heavy production in manufacturing plants, the precision and accuracy for fine tool room work, and the capacity for a wide variety of general use.

The lathe here has eight changes of spindle speed. Four speeds direct from the belt driven cone and four more thru application of the back gears; giving the operator the variety of speeds necessary to take care of the class of work he has to do. The spindle is hollow to allow long rods, bars or tubing to be passed thru for machining. A draw-in collet chuck, of either hand wheel or quick acting hand lever type may be used for this kind of work.

The lead screw controls the carriage travel and has six Acme threads per inch. The accuracy and precision with which an operator can make thread gauges, taps, screw gauges, etc., is governed by the lead screw. Therefore the threads of the lead screw are used for thread cutting only. A spline in the lead screw drives a worm in the apron which operates both the automatic longitudinal and cross feeds. An automatic safety interlock prevents any possibility of the thread cutting split nuts and friction automatic feeds becoming engaged at same time.

The compound rest is graduated on the base 180 degrees, permitting it to be clamped to feed the cutting tool at any desired angle. The compound rest screw collar and cross feed screw collar are both graduated to read in one-thousandths of an inch. For ordinary taper turning, a set-over arrangement of the tailstock is made. Other tapers can be obtained by using the taper attachment described on page 82.

The quick change gear box provides 48 changes of pitch for cutting screw threads, either right or left hand, ranging from 2 to 112 threads per inch. It also controls the various automatic longitudinal and automatic cross feeds.

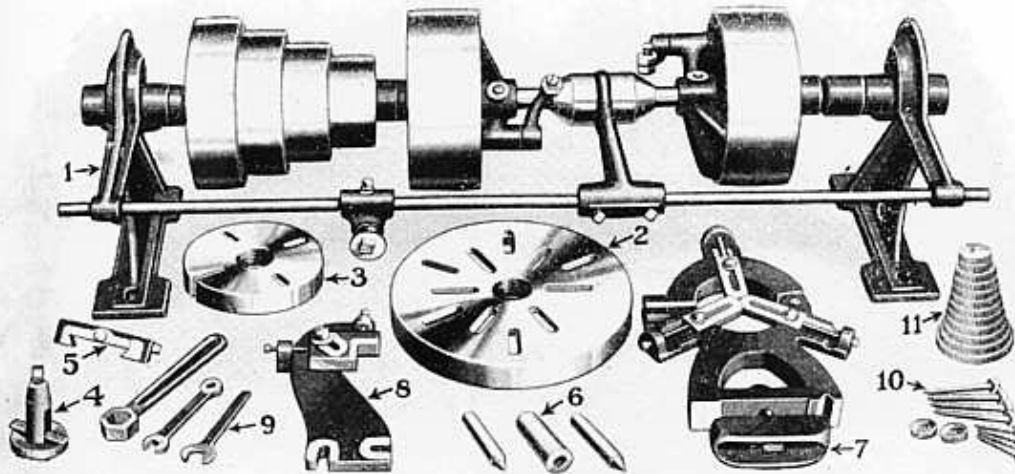

COUNTERSHAFT AND REGULAR EQUIPMENT OF A MODERN BACK GEARED SCREW CUTTING PRECISION LATHE

The regular equipment of a Screw Cutting Lathe is shown above and is included in the price of the lathe. On the arrival of the new lathe, check off each part of the equipment as described in the list below to see that none of the parts are lost or broken. The items illustrated above are furnished with the Lathes shown and described on pages 20 and 129 of this book.

1. The Improved Double Friction Countershaft is efficient and durable. It is accurately balanced and can be operated at high speed without vibration. Two Drive Pulleys equipped with Quick Acting Rim-Grip Friction Clutches expand against the rim. One Pulley used for cross belt furnishes reverse drive. Pressure grease cups lubricate the hub of the clutch pulleys. The countershaft bearings are adjustable in the hangers and are provided with felt wick oilers.

2. The large Face Plate threaded and fitted to the spindle nose of lathe.

3. The small Face Plate threaded and fitted to the spindle nose of lathe.

4. Tool Post, Ring, Wedge and Wrench are drop forged steel, case hardened. The Tool Post set screw is tool steel hardened and tempered.

5. Adjustable thread cutting stop for regulating the depth of chip in thread cutting.

6. Two tool steel Lathe Centers, one soft for head and the other hard for tail spindle and a taper sleeve for the head spindle.

7. Center Rest to support long, slender work while being turned and for supporting work while drilling, boring, reaming, etc.

8. Follower Rest which travels with the cutting tool for supporting long, slender work while being machined between centers.

9. Wrenches for Tailstock, Compound Rest and Tool Post.

10. Lag Screws for fastening lathe and countershaft.

11. Change Gears for thread cutting, automatic cross and longitudinal feeds, on Standard Change Gear Lathes.

Note: Change Gears are not required on Quick Change Gear Lathes as the gear box takes care of the changes. Change Gears are furnished only with Standard Change Gear Lathes.

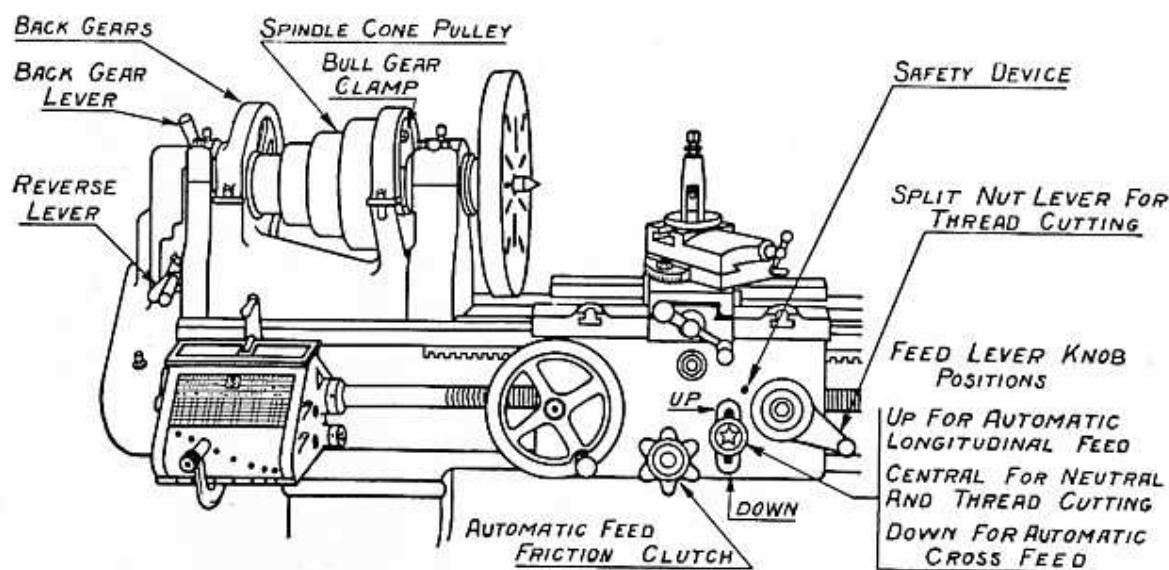

Fig. 413.—Operating Parts of a Lathe

STARTING THE NEW LATHE

Before starting the new lathe, study the action of the principal operating parts. These are marked in the illustration above and described herewith.

DIRECT CONE DRIVE OF THE SPINDLE

To prepare the spindle to operate on direct cone drive, throw the back gear lever outward from you. This causes the back gears to move out of mesh. Then loosen the bull gear clamp and slide it upward until it enters the recess in the spindle cone. If the bull gear clamp does not enter the recess readily, rotate the cone until you feel the clamp entering the slot. Then tighten the clamp and the spindle is connected for direct cone drive.

BACK GEAR DRIVE OF THE SPINDLE

To connect the back gears with the spindle, loosen the bull gear clamp. Move it to a down position and fasten. This disconnects the cone and allows it to revolve freely on the spindle. Then pull the back gear lever forward. This will bring the back gears into mesh. The lathe is now connected for back gear drive.

Never throw the back gears IN or OUT of mesh while the lathe spindle is revolving.

THE REVERSE LEVER

The reverse lever is located on the left hand end of the head stock. It is used to connect the lathe spindle through a train of gearing, with the lead screw to drive the carriage in either direction. This reverse lever has three positions: position **up**, position **central** and position **down**. When the reverse lever is in central position, the lead screw is disconnected from the spindle.

Never change the position of the reverse lever in either direction while the lathe spindle is revolving.

THE AUTOMATIC FRICTION CLUTCH

The automatic friction clutch controls the operation of both the automatic longitudinal feed and the automatic cross feed. If, therefore, the automatic feeds are not in use, the friction clutch knob should be loosened or unscrewed a couple of turns to the left.

THE AUTOMATIC FEED LEVER KNOB

The automatic feed lever knob is used for operating the automatic longitudinal feed and the automatic cross feed. The automatic feed lever knob in the apron has three positions: position up, position central and position down.

AUTOMATIC LONGITUDINAL FEED OF THE CARRIAGE

To connect the automatic longitudinal feed of the carriage of a Quick Change Gear Lathe to feed from right to left in the direction of the head stock, move the reverse lever to a down position. Move automatic feed lever knob into up position and fasten, then tighten automatic friction clutch.

For the Standard Change Gear Lathe, the position of the reverse lever for automatic longitudinal feed may be up or down according to whether simple or compound gearing connects the spindle with the lead screw.

AUTOMATIC CROSS FEED

To connect the automatic cross feed on a Quick Change Gear Lathe, loosen the automatic feed lever knob and move it to down position and fasten, then tighten the automatic friction clutch. The automatic cross feed is in action for feeding the tool in the direction of the operator from the axis of the spindle, providing the reverse lever is in down position.

For the Standard Change Gear Lathe the position of the reverse lever for automatic cross feed, may be up or down according to whether simple or compound gearing connects the spindle with the lead screw.

The automatic feed lever knob is controlled by a safety device. For example: when cutting a thread the automatic feed lever knob is locked in central position and while in this position, it is impossible for either of the automatic feeds to get into action. For description of safety device see page 24.

SPLIT NUT LEVER FOR THREAD CUTTING

The split nut lever controls the split nuts or half nuts in the apron that clamp on the lead screw for thread cutting.

When the split nut lever is in down position the split nuts are open, and out of contact. When the split nut lever is in up position, the split nuts are clamped on the thread of the lead screw ready for thread cutting.

The thread of the lead screw is used for thread cutting only, as both the automatic feeds in the apron are driven by the spline in the lead screw and not by the thread of the lead screw.

SAFETY DEVICE FOR SOUTH BEND LATHES

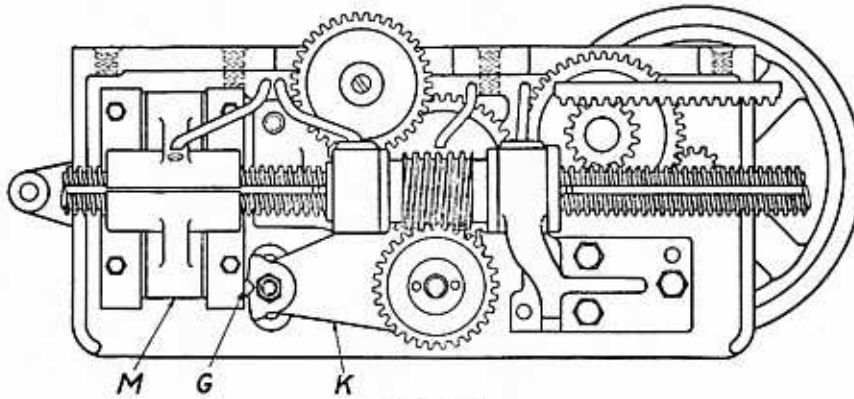

Fig. 414

the lead screw while either the automatic cross feed or automatic longitudinal feed is in action.

Figure 414 shows the interior view of the improved apron on South Bend Lathes. "G" Safety device. "K" Automatic feed lever. "M" Split half nuts.

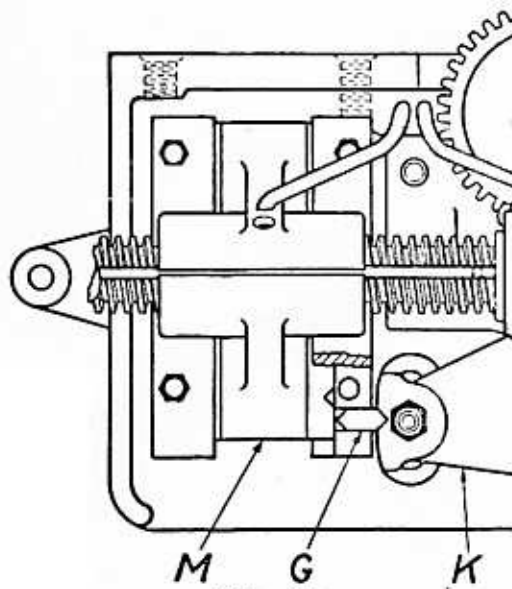

Fig. 415

Set for Thread Cutting

Figure 415 shows the mechanism of the casting cut away to show the action of the safety device when cutting threads. Split nuts "M" are closed on the lead screw. Feed lever "K" is locked in neutral position.

Set for Automatic Feed

Figure 416 shows the safety device "G" locking split half nuts in an open position. It also shows the feed lever "K" in position for operation of automatic longitudinal feed. For automatic cross feed operation, slide feed lever "K" to the bottom of the slot.

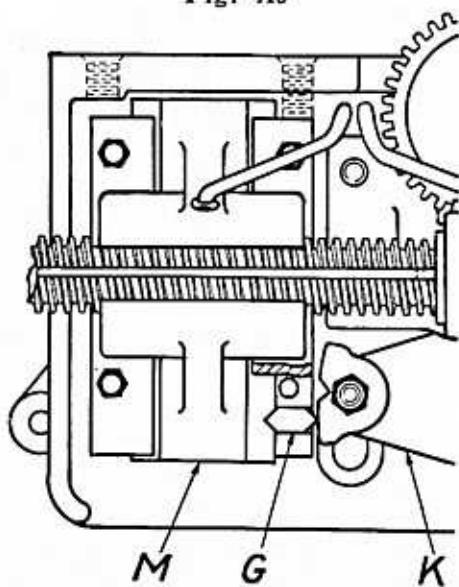

Fig. 416

Safety Device is Fool Proof

This safety device is fool proof. It works automatically without any attention from the operator. The feed mechanism is also fool proof, as the automatic cross feed and the automatic longitudinal feed cannot be engaged at the same time.

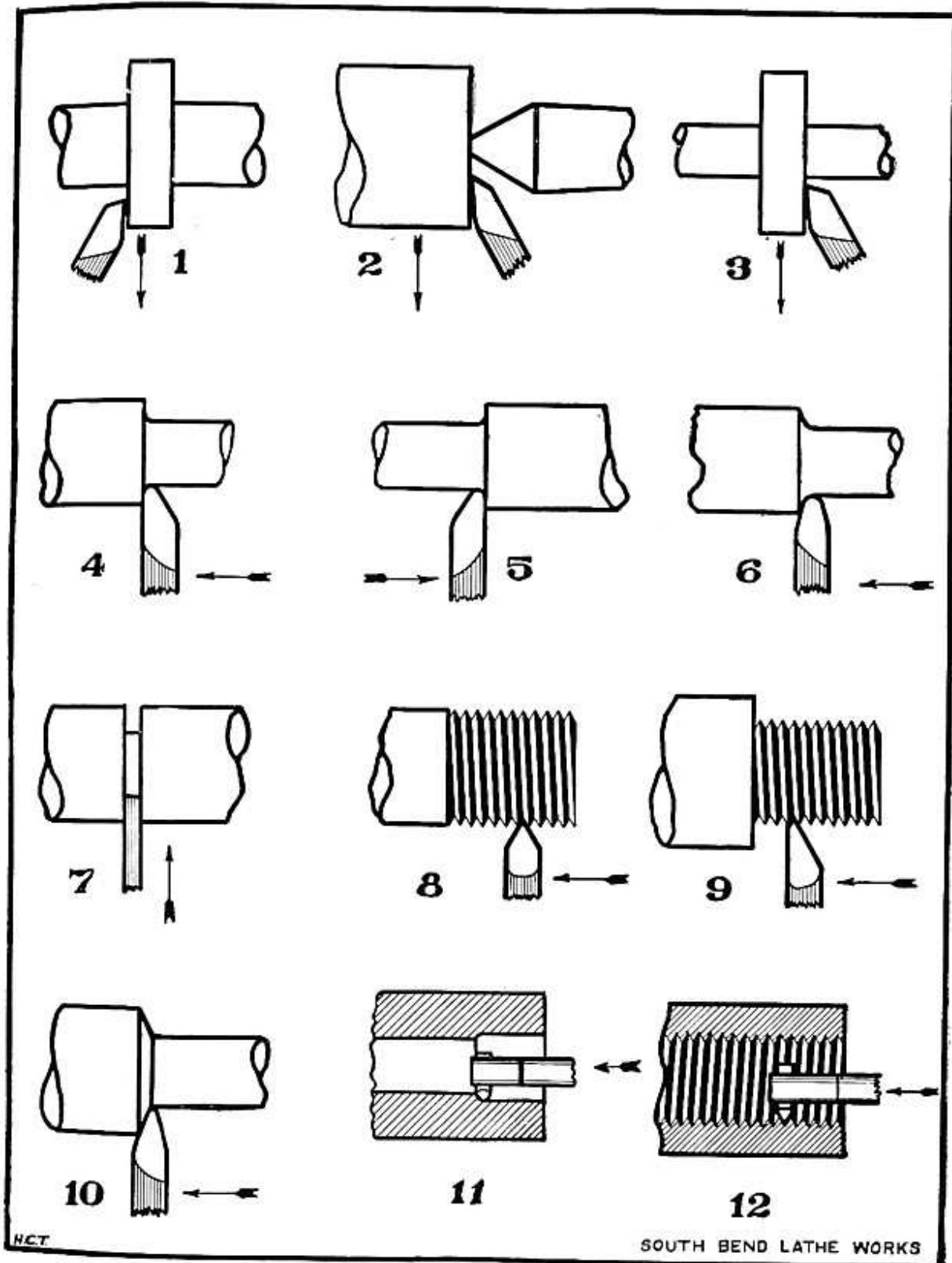

Fig. 417.—Application of Lathe Tools

- | | |
|---------------------------------|------------------------------------|
| No. 1. Left Hand Side Tool. | No. 7. Cutting-off Tool. |
| No. 2. Right Hand Side Tool. | No. 8. Threading Tool. |
| No. 3. Right Hand Corner Tool. | No. 9. Right Hand Threading Tool. |
| No. 4. Right Hand Turning Tool. | No. 10. Round Nose Finishing Tool. |
| No. 5. Left Hand Turning Tool. | No. 11. Internal Boring Tool. |
| No. 6. Round Nose Turning Tool. | No. 12. Internal Threading Tool. |

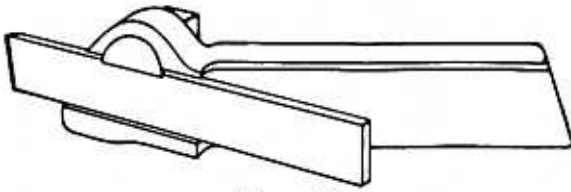

Fig. 418

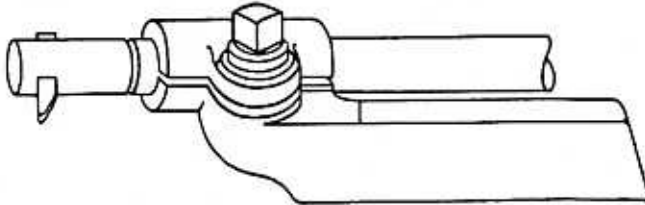

Fig. 419

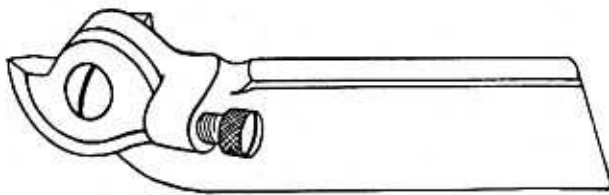

Fig. 420

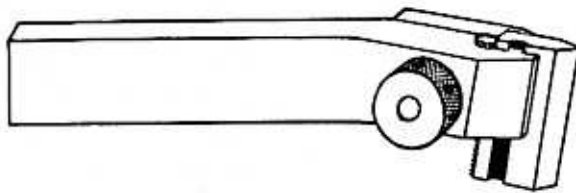

Fig. 421

Fig. 418 is a cutting off tool, hardened and ground, ready for use. The blade has clearance on both sides, and requires grinding only on the end.

Fig. 419 is a boring tool with an adjustable bar in which small hardened steel bits are inserted. This tool may be used also for internal thread cutting.

Fig. 420 is a threading tool, the cutter of which is hardened and ground, and is adjustable. This cutter requires grinding on the top edge only. It therefore always remains true to form and angle.

Fig. 421 is a threading tool, holding an adjustable cutter that is hardened and ground to shape, and requires grinding on the top edge only to sharpen.

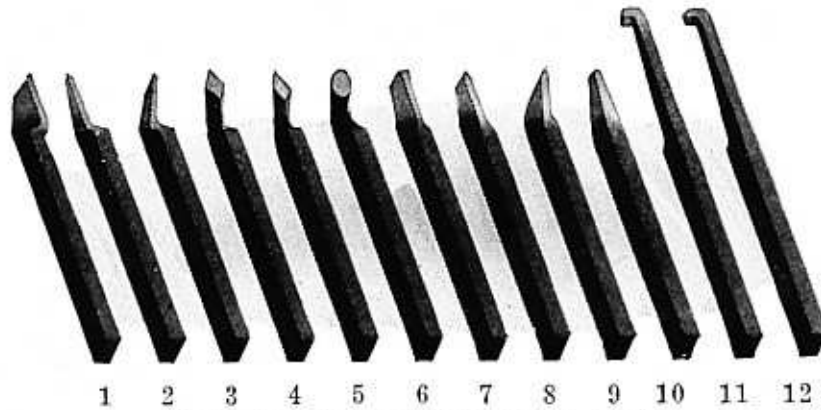

Fig. 422. Forged Steel Lathe Tools

- | | |
|------------------------------|----------------------------|
| 1. Left-hand Side Tool. | 7. Cutting-Off Tool. |
| 2. Right-hand Side Tool. | 8. Threading Tool. |
| 3. Right-hand Bent Tool. | 9. Bent Threading Tool. |
| 4. Right-hand Diamond Point. | 10. Roughing Tool. |
| 5. Left-hand Diamond Point. | 11. Boring Tool. |
| 6. Round Nose Tool. | 12. Inside Threading Tool. |

FORGED STEEL LATHE TOOLS

Fig. 422 shows twelve forged carbon steel lathe tools used in the various machining operations on the lathe. The forged lathe tool is used more on large lathes for heavy work.

High Speed Forged Steel Lathe Tools

The twelve forged steel lathe tools illustrated above may also be made of high speed steel.

LATHE TOOLS

The lathe tool is used for the cutting and machining of metals in the lathe. It is held in the tool post of the compound rest, and is fed to the revolving work by hand feed or by automatic feed.

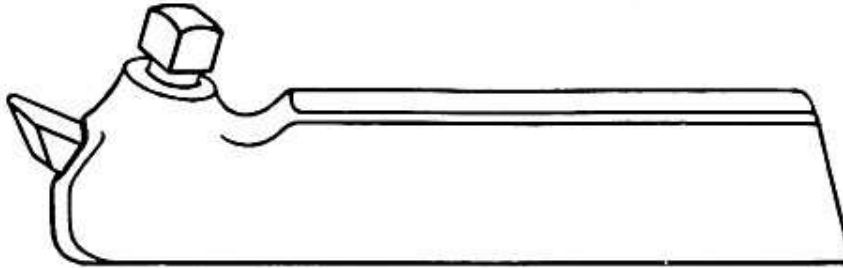

Fig. 423.—Tool Holder with Inserted Cutting Bits of High Speed Steel

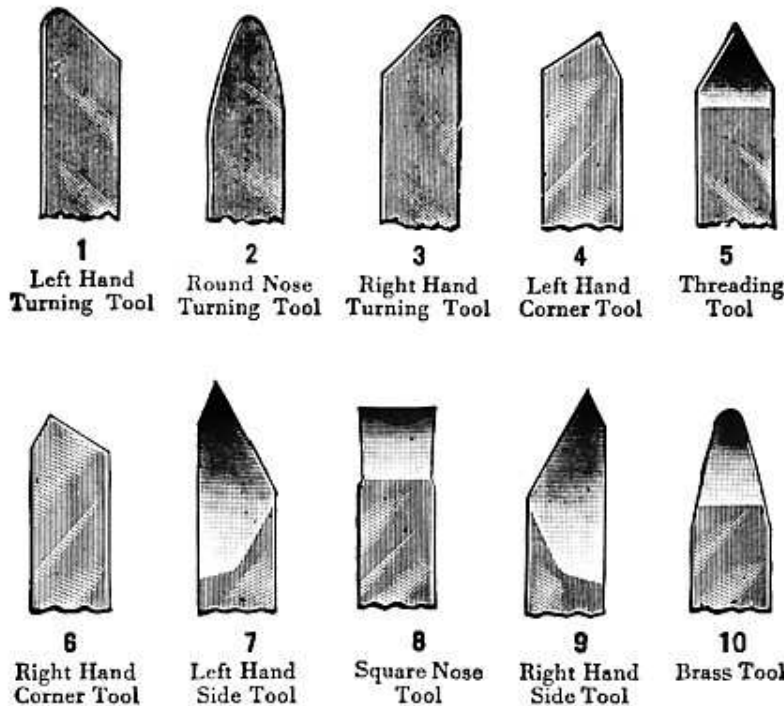

Fig. 424.—High Speed Cutting Bits Ground to Form

Right hand.—A right hand tool is one that takes a cutting chip while the feed is operating from right to left, or feeding towards the head stock.

Left hand.—A left hand cutting tool is one that takes a cutting chip from left to right, or feeding towards the tail stock.

HIGH SPEED STEEL BITS

Require grinding only to make them ready for use in Lathe Tool Holders



High Speed Steel Bits for Tool Holders

Size of Squares...	$\frac{3}{16}$ "	$\frac{1}{4}$ "	$\frac{5}{16}$ "	$\frac{3}{8}$ "	$\frac{7}{16}$ "
Length	$1\frac{3}{4}$ "	$2\frac{1}{8}$ "	$2\frac{3}{4}$ "	$3\frac{1}{4}$ "	$3\frac{3}{4}$ "
Price Each15	.20	.35	.55	.90

GRINDING OR SHARPENING THE CUTTING EDGE OF THE LATHE TOOL

The efficiency of the lathe tool depends a great deal upon the way it is ground or sharpened. The cutting edge of the tool must have the proper side clearance, front clearance, side rake and back rake.

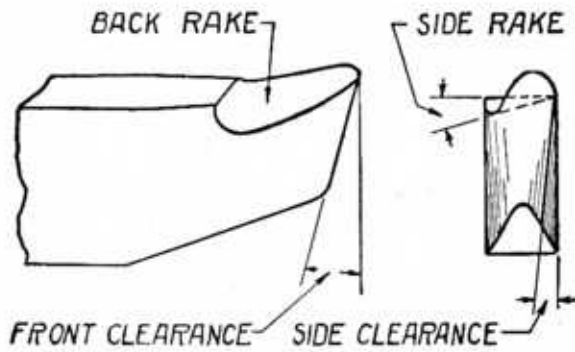

Fig. 425

Cutting Edge of Tool

Fig. 425 illustrates the front clearance, the side clearance, the side rake and the back rake of the cutting edge of the tool. All of these angles are important, and should be remembered when grinding a cutting tool.

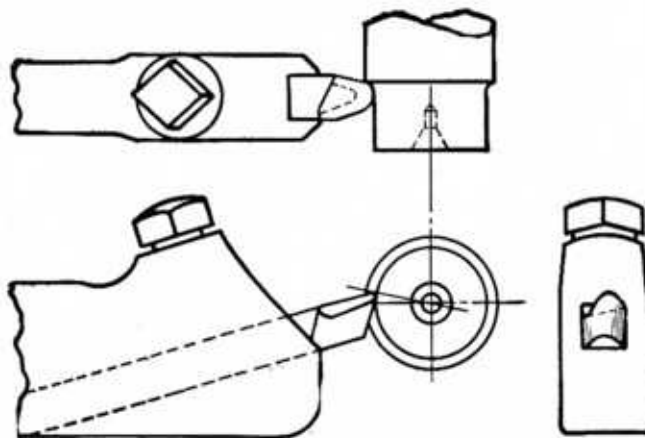

Fig. 426.—For Cutting Mild Steel

Angle of Tool for Cutting Mild Steel

Fig. 426 illustrates a ground cutting tool for the machining of mild steel.

The angles of back rake and side rake are quite pronounced, as are also the angles of front clearance and side clearance.

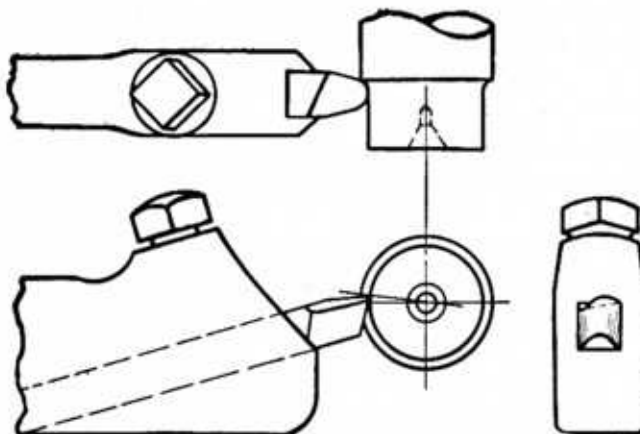

Fig. 427.—For Cutting Carbon Tool Steel and Cast Iron

Angle of Tool for Cutting High Carbon Steel and Cast Iron

Fig. 427 illustrates the tool for cutting annealed tool steel and high carbon steel and cast iron. The angle of clearance and rake are not so sharp as in the tool for cutting steel, but then there is sufficient slope and clearance.

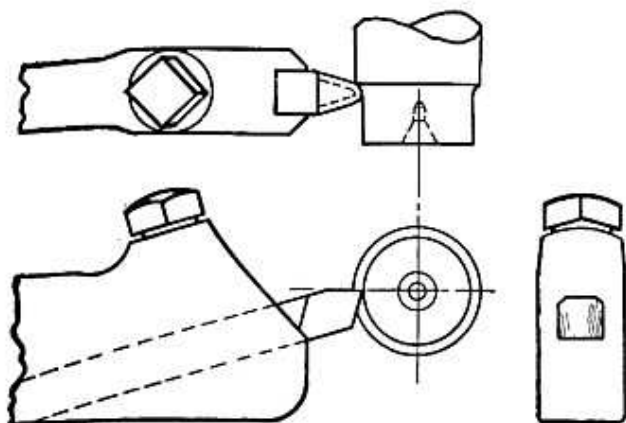

Fig. 428.—Turning Tool for Bronze Work

**Angle of Tool for Cutting
Bronze and Brass**

Fig. 428 shows the turning tool ground for machining bronze and brass. You will note that the tool has no back or side rake, and that the cutting edge of the tool is on the center line.

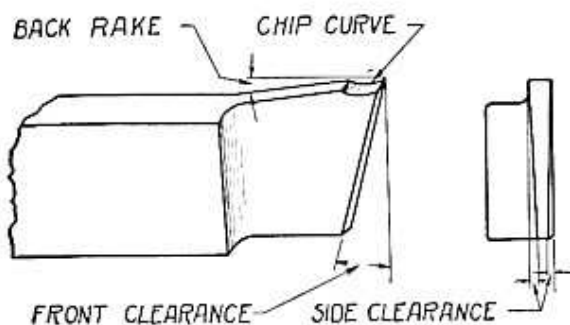

Fig 429.—Cutting Off Tool

Fig. 429 shows a cutting off or parting tool ground for machining both steel and cast iron. There is back rake, a chip curve, front clearance and side clearance but no side rake. The side clearance is very important on a cutting off tool.

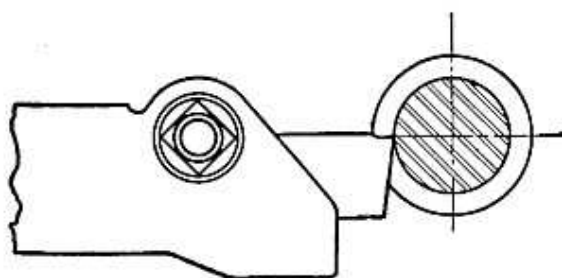

Fig. 430.—Cutting Off Tool in Holder

Fig. 430 shows a cutting off tool in a tool holder. Note that the cutting edge of the tool is on a center line with the work.

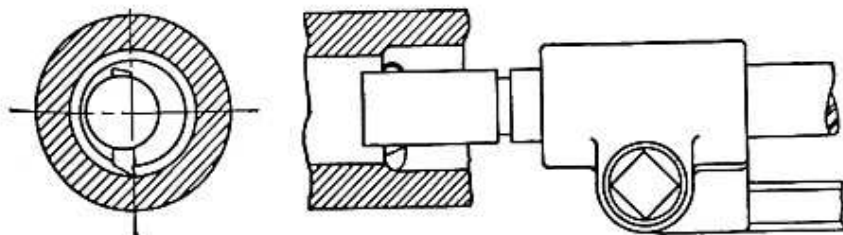

Fig. 431.—Boring Tool Cutting Edge

Fig. 431 shows the cutting edge of a boring tool. There is both a side rake and a back rake to this cutting edge and the front and side clearance is

about the same as for the turning tool. The height of the cutting edge is exactly on the center line.

HEIGHT OF THE CUTTING TOOL FOR TURNING STEEL AND CAST IRON

The position of the cutting edge of a turning tool for machining metal is important. In the cutting of mild steel and cast iron, the best results are obtained when the cutting point of the tool is about $\frac{3}{16}$ " above the center for each inch in diameter of the work.

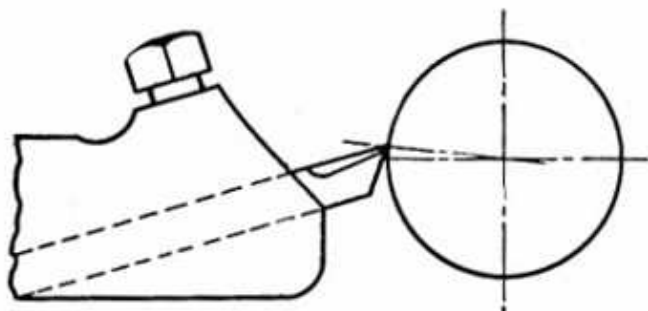

Fig. 432.—Position of Turning Tool

Insert the tool holder in the tool post and raise or lower the point of the tool to the height indicated in the preceding paragraph by moving the wedge in or out of the tool post ring. To test this height run the cross slide in until the point of the tool is opposite the tail center point.

HOLDING THE TOOL IN THE TOOL POST

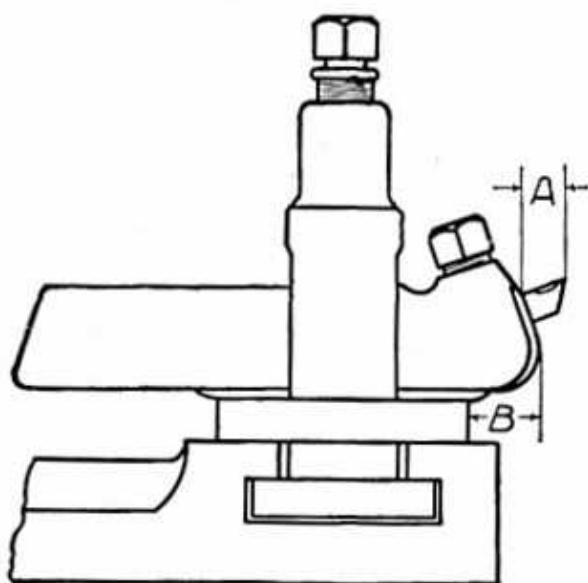

Fig. 433.—The Tool Holder

The tool holder should be held firmly in the tool post. The end of the holder should not extend too far from the edge of the compound rest. See "B," Fig. 433, which is about the correct distance.

The cutting edge of the tool bit should not extend far beyond the holder. See "A," Fig. 433 which is about the correct distance. When the tool bit extends too far from the holder or the tool holder extends too far from the tool post, the tool will spring and the tool point catch in the work, destroying both tool and work.

KEEP THE CUTTING TOOLS SHARP

The cutting tools must have a sharp, keen edge, in order to do fine accurate work. First-class workmen take pride in keeping their tools in condition. After grinding a tool on the emery wheel, its wearing qualities will be improved if it is honed by hand with a small oil stone, using a couple of drops of oil.

MEASURING WITH CALIPERS

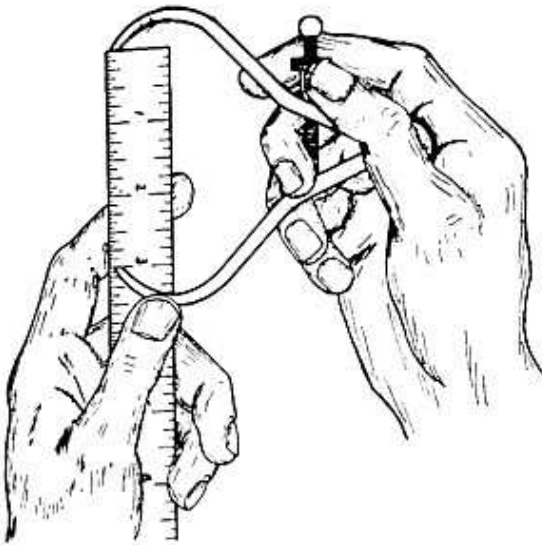

Fig. 434.—Setting the Outside Caliper

Setting an Outside Caliper to a Steel Scale

Fig. 434 shows a method of setting an outside caliper to a steel scale. The scale is held in the left hand and the caliper in the right hand. The caliper is supported by the thumb of the left hand and the adjustment is made with the thumb and first finger of the right hand.

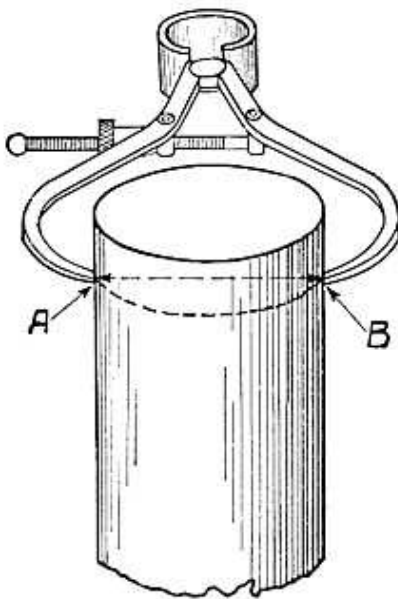

Fig. 435.—Position of Caliper in Measuring Diameters

Correct Position of the Caliper in Measuring the Diameter of a Cylinder

Fig. 435 shows the proper application of the outside caliper when measuring the diameter of a cylinder or a shaft. Note the dotted line connecting points "A" and "B" where the caliper comes in contact with the work, is at right angles to the center line of the work, and at a point where the true diameter of the cylinder can be measured. When the caliper measures properly, it should just slip over the shaft of its own weight. Never force a caliper. It will spring and the measurement will not be accurate.

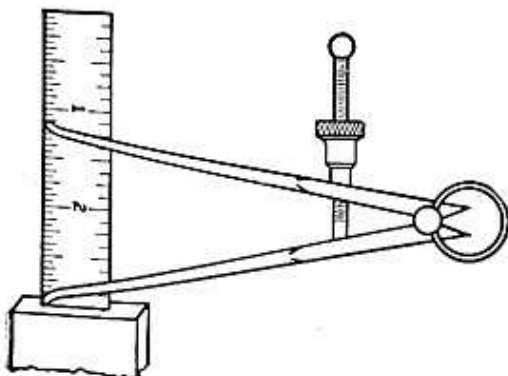

Fig. 436.—Setting the Inside Caliper

Setting an Inside Caliper to a Scale

To set an inside caliper for a definite dimension, place the end of the scale against a flat surface and the end of the caliper at the edge and end of the scale. Adjust the other end of the caliper to the required dimension.

APPLICATION OF INSIDE CALIPER

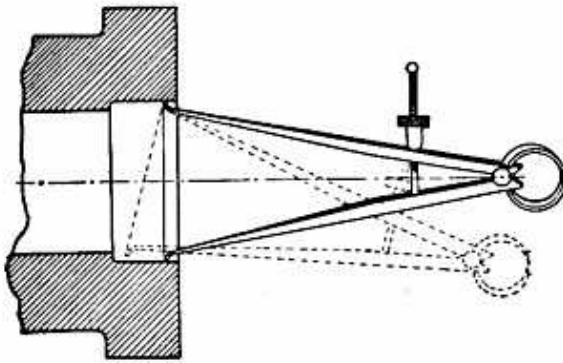

Fig. 437.—Using the Inside Caliper

In measuring the diameter of a hole place the caliper in the hole as shown on the dotted line and raise the hand slowly. Adjust the caliper in the meantime, then take another cut with the boring tool, and test with the caliper again. Continue until the proper dimension is obtained. **Do not force the caliper.** Develop a fine "caliper touch." Be sure the points of the caliper are across the diameter of the hole being measured.

Transferring Measurement from an Outside to an Inside Caliper

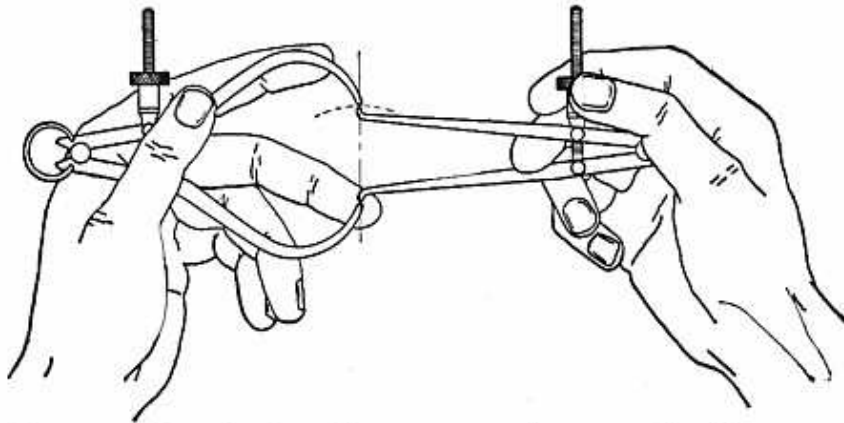

Fig. 438.—Transferring Measurement from an Outside to an Inside Caliper

Fig. 438 shows the method of transferring measurement from an outside to an inside caliper. The point of one leg of the inside caliper rests on a similar point of the outside caliper. Using this contact point as

a pivot, move the inside caliper along the dotted line shown in illustration, and adjust with the thumb screw until you feel your measurement is just right.

If you wish to transfer measurement from an inside caliper to an outside caliper, reverse the process described above, holding the inside caliper in the left hand and the outside caliper in the right hand.

Caliper FEEL

The accuracy of all contact measurements is dependent upon the touch or feel. Therefore the contact measuring tool should be held by the fingers only, and in such a way as to bring it in contact with the finger tips. The caliper should be delicately and lightly held, instead of gripped tightly, because if the caliper is gripped harshly between the fingers, the sense of touch is very much impaired.

LATHE CATALOG

If interested in securing further information on any of the lathes, tools or accessories described in this hand book, write for a free copy of our illustrated catalog, which describes the entire line, also giving the prices.



Fig. 439.—Using a Micrometer Caliper Measuring Work in the Lathe

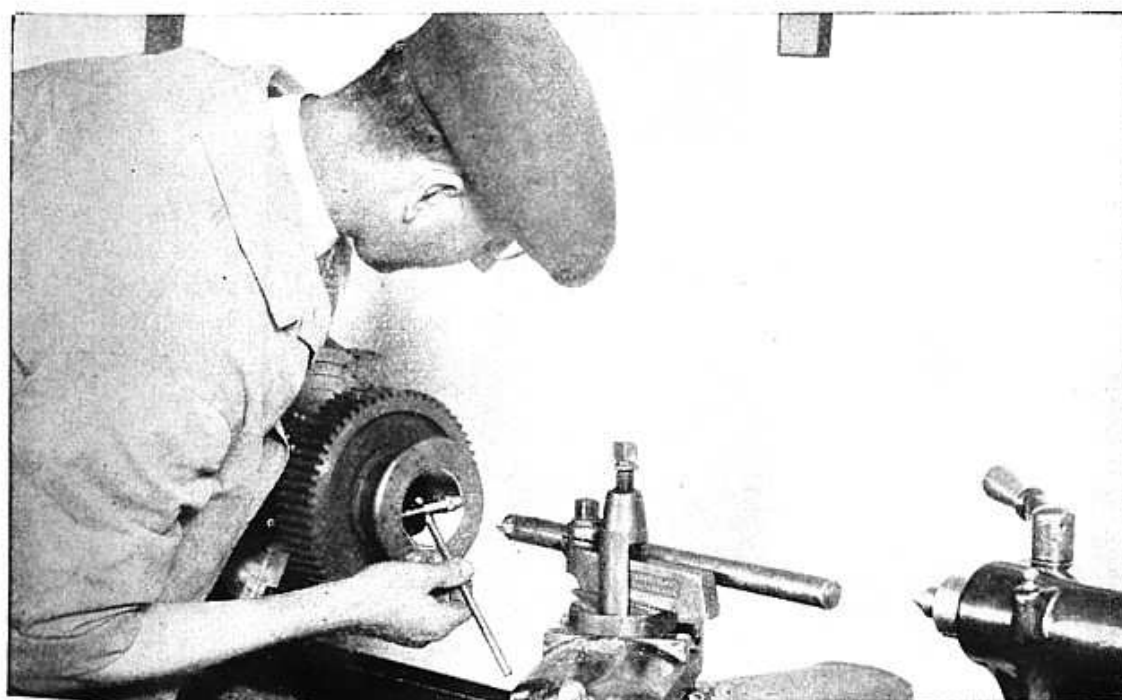

Fig. 440.—Using an Internal Micrometer Caliper Measuring the Diameter of a Machined Hole

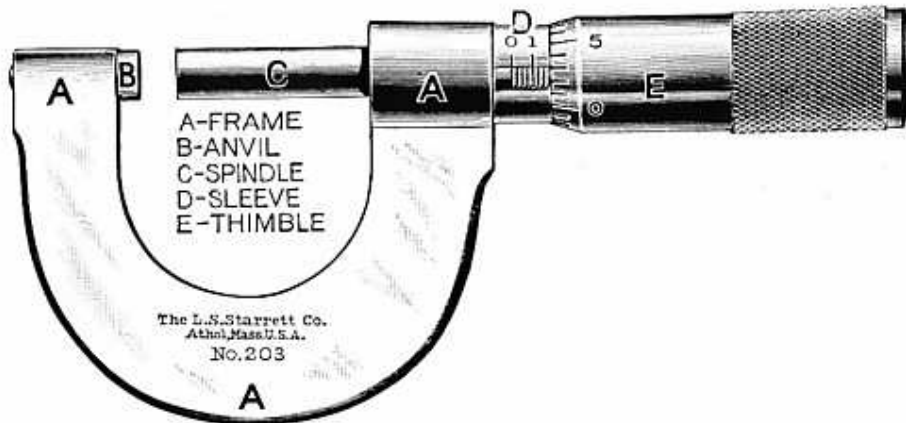

Fig. 441

HOW TO READ A MICROMETER

The pitch of the screw threads on the concealed part of the spindle is forty to an inch. One complete revolution of the spindle, therefore, moves it lengthwise one fortieth (or twenty-five thousandths) of an inch. The sleeve D is marked with forty lines to the inch, corresponding to the number of threads on the spindle.

Each vertical line indicates a distance of one-fortieth of an inch. Every fourth line is made longer than the others, and is numbered 0, 1, 2, 3, etc. Each numbered line indicates a distance of four times one-fortieth of an inch, or one tenth.

The beveled edge of the thimble is marked in twenty-five divisions, and every fifth line is numbered, from 0 to 25. Rotating the thimble from one of these marks to the next moves the spindle longitudinally one twenty-fifth of twenty-five thousandths, or one thousandth of an inch. Rotating it two divisions indicates two thousandths, etc. Twenty-five divisions will indicate a complete revolution, .025 or one-fortieth of an inch.

To read the micrometer, therefore, multiply the number of vertical divisions visible on the sleeve by twenty-five and add the number of divisions on the bevel of the thimble, from 0 to the line which coincides with the horizontal line on the sleeve. For example, in the engraving, there are seven divisions visible on the sleeve. Multiply this number by twenty-five, and add the number of divisions shown on the bevel of the thimble, 3. The micrometer is open one hundred and seventy-eight thousandths. ($7 \times 25 = 175 + 3 = 178.$)

Young man, learn the machinist's trade, learn mechanical drawing. If you master both subjects you will be a trained man and your future will be limited only by your ability.

CENTERING

To machine a job on centers in the lathe it is necessary that a hole be drilled in each end of the work so it can revolve on the lathe centers. These holes are called countersunk center holes.

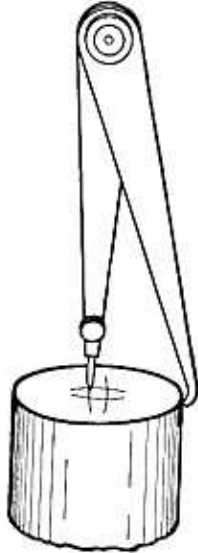

Fig. 442.—The Hermaphrodite Caliper

Locating Centers with a Hermaphrodite Caliper

Place the work to be centered in a vise. Face the end of the work with chalk and then rub in with your finger so that the marks of the caliper can be seen. Set the caliper to a little over half of the diameter of the stock and mark as shown in Fig. 442. Drive the center punch point in the center of these marks. Repeat this operation on the other end of the work.

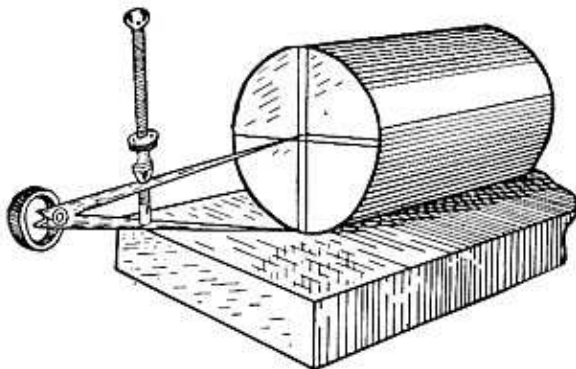

Fig. 443.—Dividers

Locating Centers with Surface Plate and Dividers

If hermaphrodite calipers are not available, the center can be located with a surface plate and dividers. See Fig. 443.

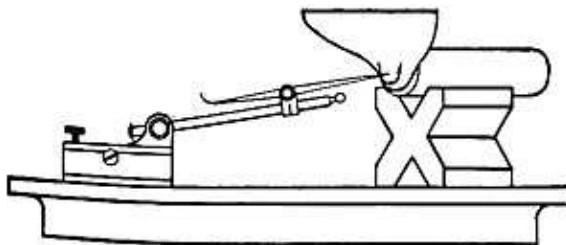

Fig. 444.—Surface Gauge and V-Block

Locating Centers with Surface Gauge and V-Block

When work is of irregular shape, a surface gauge can be used to locate the centers. See Fig. 444. This shows the tool rest of an emery grinder on a V-Block on a surface plate. The centers at both ends of this tool rest are located by the aid of the surface gauge.

George Westinghouse, Henry Ford and Orville Wright got their early mechanical training on a small screw cutting lathe.

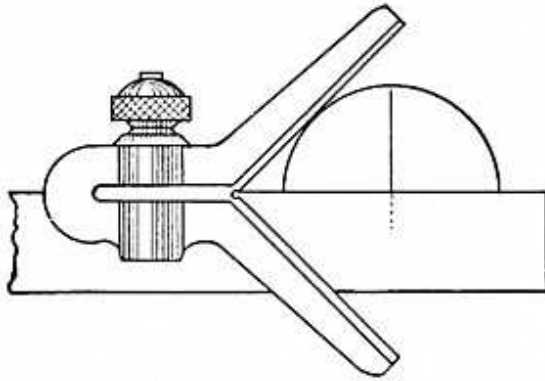

Fig. 445.—Center Head

Locating Centers with a Center Head

Another method of locating the centers is with a center head as shown in Fig. 445. Make a mark along the side of the blade on the end of the work, then turn the square one-quarter way around and make a similar mark on the end. This is a quick method of locating the center on round stock.

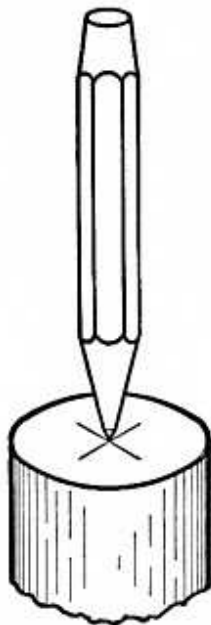

Fig. 446.—Center Punch

Punching the Center Point

Location of the center being found, place the center punch at the intersection of the lines and tap with a hammer, making a mark sufficiently deep so that the work will revolve on the center points when placed on centers in the lathe. See Fig. 446.

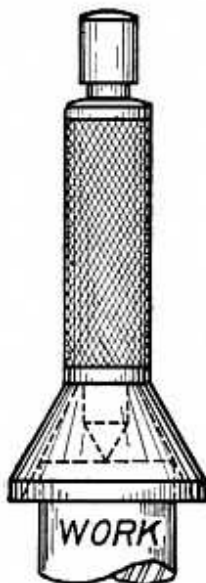

Fig. 447.—Bell Cup Center Punch

Bell Cup Center Punch

Fig. 447 shows the application of a bell cup center punch centering a small cylindrical piece of work. The bell cup is placed over the end of the work and the center punch or plunger slides through this cup. Hit the plunger a sharp blow with the hammer and it will immediately locate the center. This method is used mostly in production where a great many small pieces are to be centered.

TESTING THE WORK ON CENTERS

After a piece has been centered on both ends by the center punch, place the work on centers in the lathe. Clamp the tail stock and bring the tail stock center up tight enough so that the work will be supported between centers. With a piece of chalk in the right hand, revolve the work with the left hand and mark the high spots on each end of the cylinder.

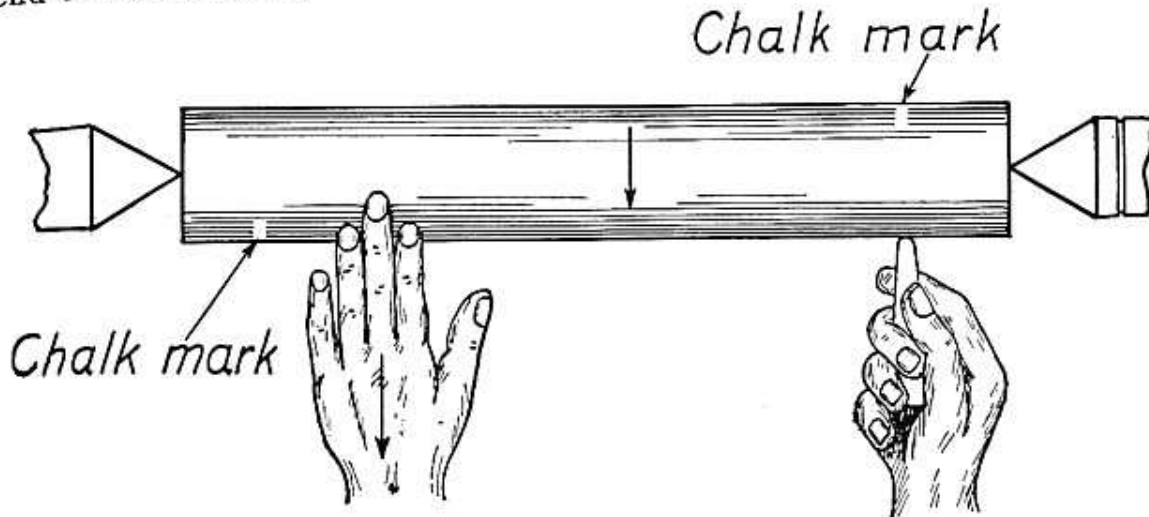

Fig. 448.—Testing the Work on Center Points

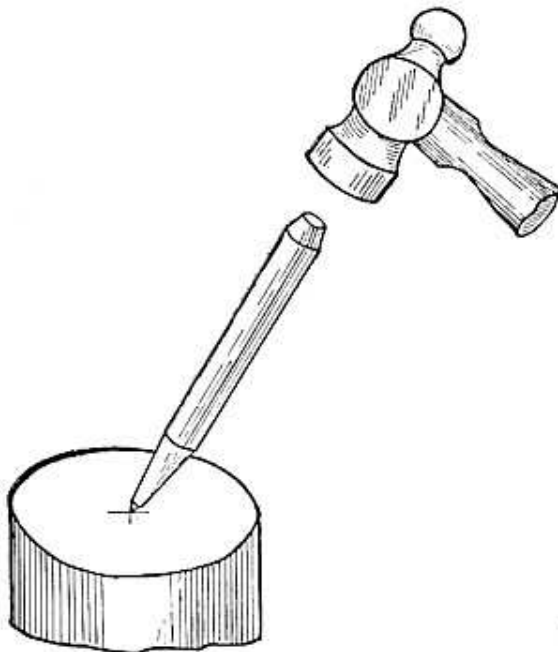

Fig. 449.—Changing Position of the Center Point

Changing the Position of Center Point

Place the work again in the vise and drive the center punch mark in the proper direction necessary to have the work run true. Complete this operation on both ends of the work and place it back on the centers and test again with chalk. When the work is running true on the centers, it is then ready for drilling and countersinking.

Straightening the Work

If the piece to be machined is close to size in the rough so that very little stock is left for machining, care should be taken to see that the bar is straight as possible and that the center holes are located accurately so that the shaft may be true all over when finished.

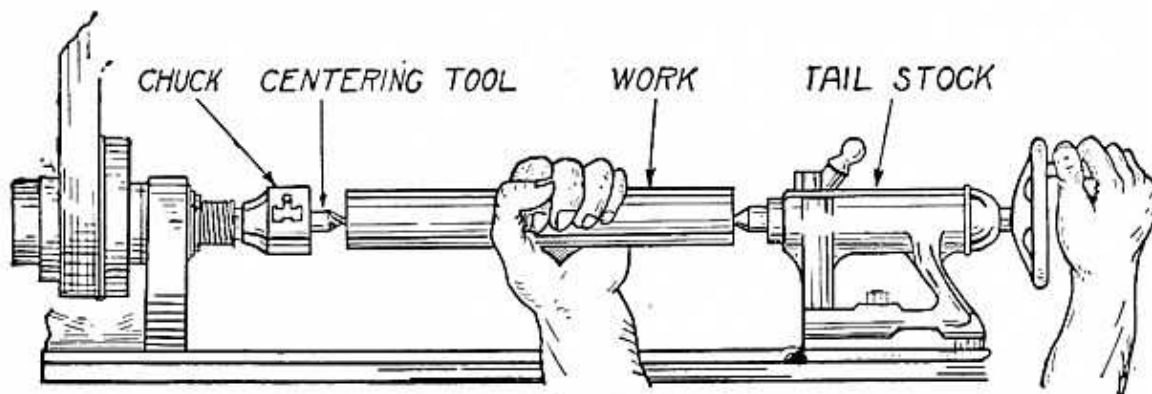

Fig. 450

COUNTERSINKING WORK ON A LATHE

Fig. 450 shows the method of countersinking a short cylindrical shaft on a lathe. We call the shaft the work.

The location of the centers on the work have already been found as indicated in a previous article. A drill chuck is placed in the head stock spindle of the lathe. A combined drill and countersink or centering tool is held in the chuck. The work is placed with the center point on the tail stock center of the lathe and held with the left hand. See Fig. 450 above. The right hand is used to feed the tail stock center and the work to the combined drill and countersink. Start the lathe and feed the work until the countersunk hole enters to the proper depth. Remove the work, place the countersunk hole on the tail spindle center and countersink the other end of the work.

In feeding work to a combined drill and countersink, a drop or two of oil should be used on the drill. The work should be fed slowly and carefully so as not to break the point of the drill. Extreme care is needed when the work is heavy because it is then more difficult to feel the proper feed of the work on the center drill.

The Broken Drill

If while countersinking a hole in the work, the center drill breaks, and part of the broken drill remains in the work, this part must be removed. Sometimes it can be driven out by a chisel or jarred loose, but it may stick so hard that it cannot be removed. In that case the broken part of the drill should be annealed, and the only way to anneal it is to anneal the end of the shaft. After steel is annealed, the broken drill may be drilled out.

TRAINING AND VOCATION

"There is a tremendous waste in the world due to the fact that many of the workers have not found the vocation for which they are adapted and are not trained in the work they are doing."—HARRIS.

Young man, give some thought to the above statement, try to find the vocation for which you are adapted and become trained in that line of work.

COUNTERSINKING CENTER HOLES

For countersinking a piece of work the combined drill and countersink is the most practical tool. See Fig. 451.



Fig. 451.—Combined Drill and Countersink

These combined drills and countersinks vary in size and the drill points also vary. Sometimes a drill point on one end will be $\frac{1}{8}$ " in diameter, and the drill point on the opposite end $\frac{3}{16}$ " in diameter. The countersink is always 60 degrees, so that the countersunk hole will fit the angle of the lathe center point which is 60 degrees.

Countersinking Center Holes with a Small Twist Drill and Special Countersink

If a combined drill and countersink is not available, the work may be centered with a small twist drill. Let the drill enter the work a sufficient length on each end, then follow with a special countersink, the point of which is 60 degrees.

Below we show two countersinks that can be made in a very short time, either one of which will do satisfactory work.

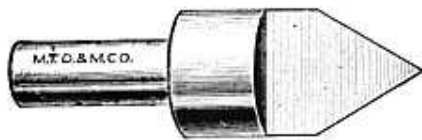

Fig. 452.—Special Countersink

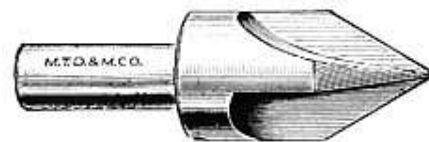
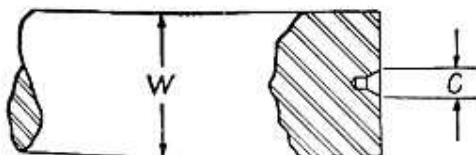

Fig. 453.—Special Countersink

Size of the Countersunk Center Hole

The drawing and tabulation below show the correct size of the countersunk center hole for the diameter of the work. This tabulation also contains the price of the carbon steel combined drill and countersinks.



Combined Drill & Countersink

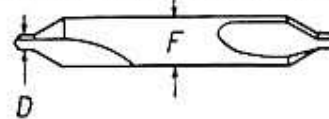

No. of Comb. Drill & Countersink	Dia. of Work W	Large Diameter of Countersunk Hole C	Dia. of Drill D	Dia. of Body F	Price Each	Price per Doz.
1	$\frac{3}{16}$ " to $\frac{5}{16}$ "	$\frac{1}{8}$ "	$\frac{1}{16}$ "	$\frac{13}{64}$ "	.25	2.25
2	$\frac{3}{8}$ " to 1"	$\frac{3}{16}$ "	$\frac{3}{32}$ "	$\frac{3}{10}$ "	.30	2.75
3	$1\frac{1}{4}$ " to 2"	$\frac{1}{4}$ "	$\frac{1}{8}$ "	$\frac{3}{10}$ "	.30	2.75
4	$2\frac{1}{4}$ " to 4"	$\frac{5}{16}$ "	$\frac{5}{32}$ "	$\frac{7}{16}$ "	.40	3.50

EXAMPLES OF COUNTERSINKING

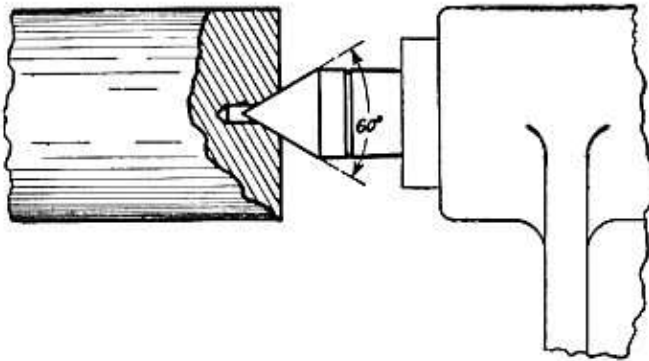

Fig. 454.—Correct Countersinking

Correct Countersinking

Fig. 454 shows the correct form and depth for countersinking work to be machined on centers. Note that the small hole is deep enough so that the point of the Lathe center does not come in contact with the bottom of the hole,

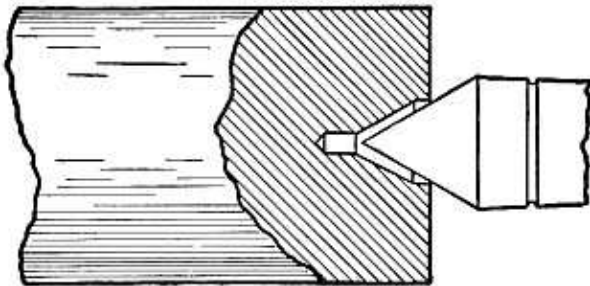

Fig. 455.—Incorrect Countersinking

Incorrect Countersinking

Fig. 455 shows a piece of work in which the countersunk hole is too deep, and that only the outer edge of the work rests on the Lathe center. Accurate work cannot be machined on centers when countersunk in this manner.

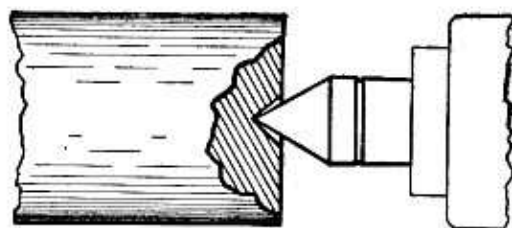

Fig. 456.—Incorrect Taper in the Work

Countersink Not Deep Enough with Incorrect Taper

Fig. 456 shows a piece of work that has been countersunk with a tool of an improper angle. This work rests on the point of the Lathe center only. It is evident that this work will soon destroy the end of the Lathe center and it will be impossible to do an accurate job.

THE COUNTERSUNK HOLE AND THE LATHE CENTER POINT

The importance of proper center holes in the work and a correct angle on the point of the lathe centers cannot be over estimated. In order to do an accurate job between centers on the lathe, the countersunk holes in the work must be the proper size and depth, and the points of the lathe centers must be true and accurate.

LATHE DOGS FOR DRIVING WORK ON CENTERS

To machine a job on centers, it is necessary to mount the work and drive this work by a Lathe Dog. The dogs vary in size for work of different diameters.



Fig. 457.—Common Lathe Dog

Common Lathe Dog

There are three kinds of dogs that are used for this purpose. The most popular is the common lathe dog. See Fig. 457. This dog is used for driving cylindrical pieces, or work having a regular section such as square, hexagon, or octagonal bars.



Fig. 458.—Safety Lathe Dog

Safety Lathe Dog

Fig. 458 is a common lathe dog, similar to the above, but instead of having the head of the set screw exposed, it has a cap over the set screw, and it is called a safety dog.

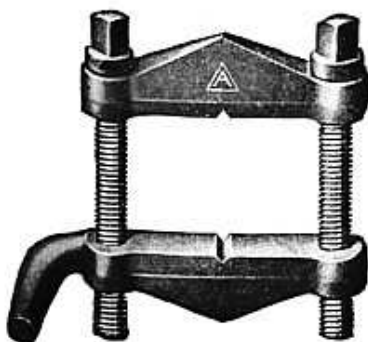

Fig. 459.—Clamp Lathe Dog

Clamp Lathe Dog

Fig. 459 is called a clamp lathe dog. It is used principally for rectangular work in the lathe.

A Face Plate Driving Stud

Work is sometimes driven between centers by a stud bolt fastened to the face plate. As for example, in driving a pulley on a mandrel, the stud extends far enough from the face plate to reach the spokes of the pulley, and drives in this manner.

MOUNTING LATHE CENTERS IN SPINDLES

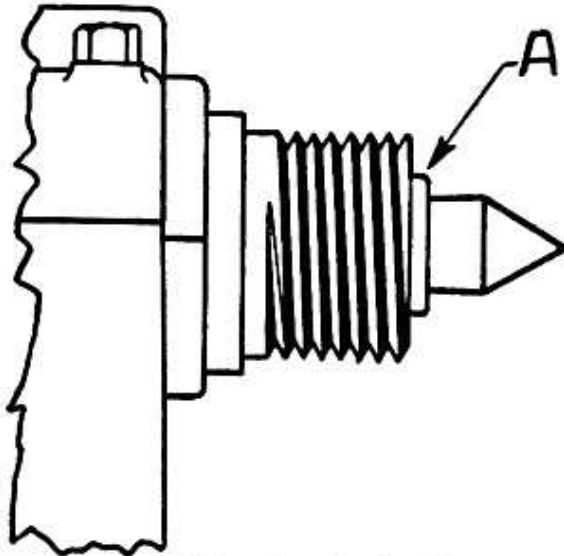

Fig. 460.—Mounting Lathe Centers

To mount lathe centers in the head stock or tail stock spindle of a lathe, thoroughly clean the tapered holes in the spindles. A little dirt left in the spindle or on the long taper of the lathe center will not permit accurate work. Never put your finger in the lathe spindle hole to remove dirt while the head spindle is revolving. Use a stick with a small piece of rag wound around it to clean the spindle hole.

Removing the Head Stock Center

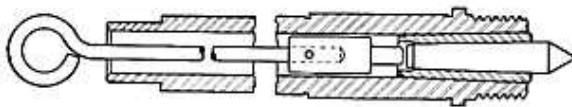

Fig. 461.—Removing the Head Stock Center

To remove the head stock lathe center, insert a $\frac{1}{2}$ " steel rod 30" long through the spindle hole. With a piece of rag in your right hand hold the sharp point of the center, while with the left hand give the rod a

sharp tap and the center will jar loose.

Fig. 461 shows a steel rod with a small bushing attached for removing the head spindle lathe center, also the taper sleeve. The small pin on the point of the bushing will drive the center out. If the sleeve is to be removed, tap with the rod again and the bushing itself will drive it out.

To Remove the Tail Stock Center

To remove the tail stock center turn the hand wheel to the left until the end of the spindle screw bumps the end of the tail center. This will loosen the center and it may be picked out of the spindle.

REMOVING THE LIVE CENTER

Before mounting a chuck on the spindle of the lathe, always remove the live center from the spindle, because if the center is not removed, the operator may forget about it and during a drilling operation he is liable to drill right through the work in the chuck and into the lathe center. When you remove the live center from the spindle, stuff a piece of rag or waste in the spindle hole so it will fit tight, in order to prevent chips and dirt getting into the taper bore of the spindle.

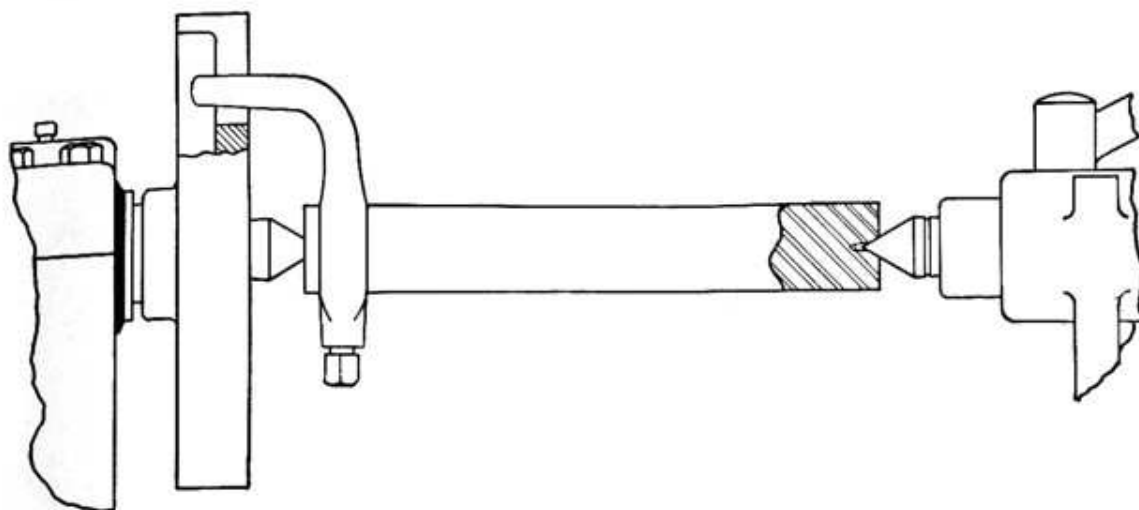

Fig. 462.—An Example of Correct Mounting of Work on Centers

Fig. 462 shows the correct method of mounting the work on centers. The driving dog is attached to the work. The tail of the dog rests in the slot of the face plate and extends beyond the base of the slot, so that the work rests firmly on both the head stock center and the tail stock center.

When mounting work on centers for machining, the tail center should not be tight against the work, but there should be a slight play between the work and the tail center. There should be a supply of oil used on the countersunk hole on which the tail center enters, because the tail center is hardened and tempered, and if the work when revolving is held too tightly by the tail center it will heat the center point and destroy both the center and the work.

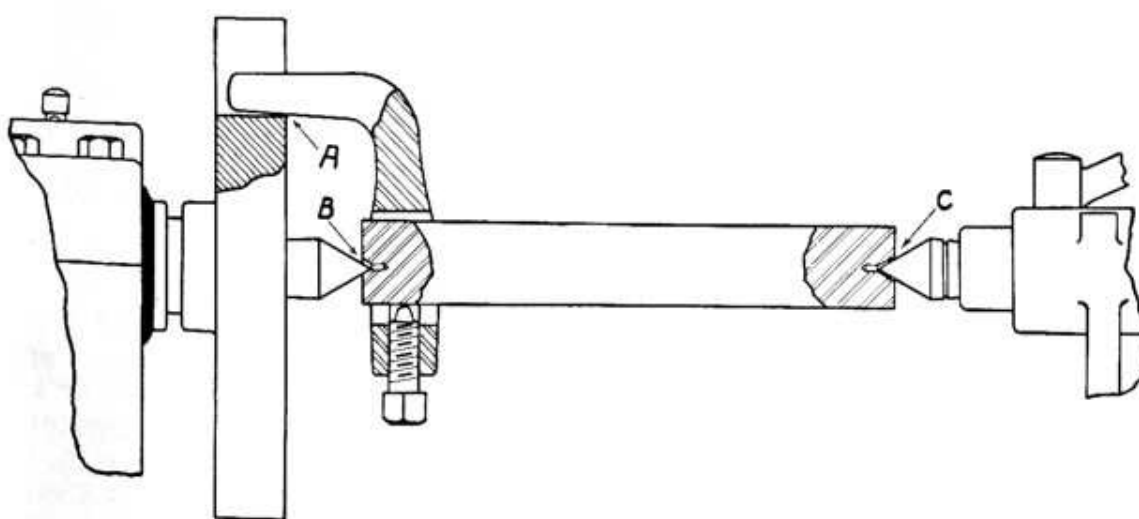

Fig. 463.—Incorrect Mounting

Fig. 463 illustrates an example of incorrect mounting on centers. The dog is fastened on the work, but the tail of the dog rests on the bottom of the slot on the face plate.

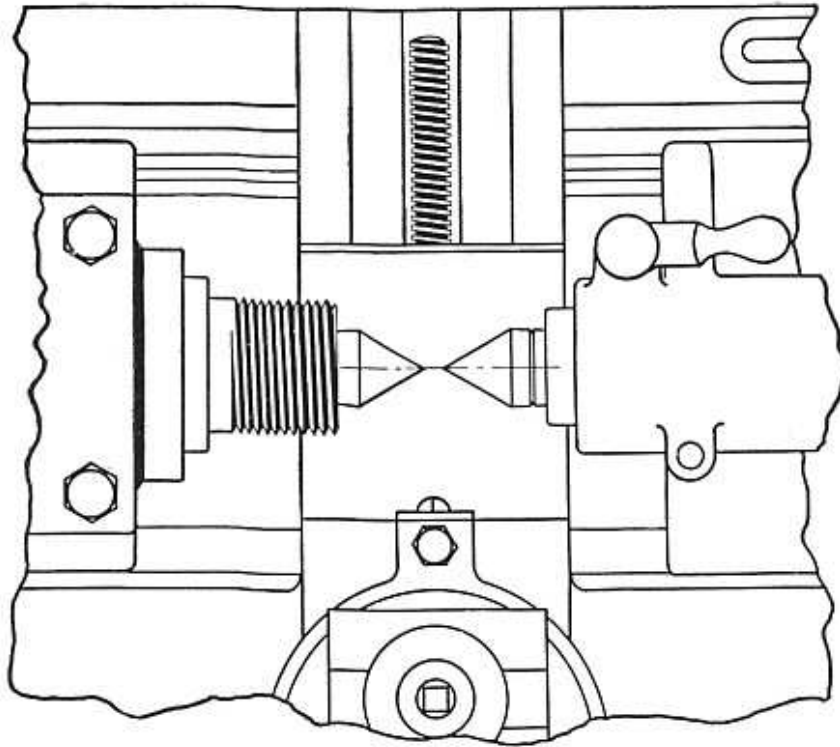

Fig. 464.—Aligning Lathe Centers

To align centers, slide the tail stock center up close to the head stock center; clamp the tail stock to the bed and then by moving the hand wheel of the tail stock spindle bring the center point close up to the point of the head stock center. If the tail stock center does not line up adjust the tail stock top in the proper direction and repeat this test and operation until the desired degree of accuracy is obtained. To test the alignment of tail stock centers, see Fig. 472, Page 50.



Fig. 465

Head Spindle Lathe Center



Fig. 466

Tail Spindle Lathe Center

Fig. 465 shows a live or head spindle lathe center that is used in the head spindle of the lathe. This center is almost always soft because it revolves with the work. It should always be kept in good condition; that is, with a sharp point and running true. It is very important that the center runs true.

Fig. 466 shows the dead or tail spindle lathe center. This center is always hardened and tempered, because it is stationary and the work revolves on it. Therefore, there is constant wear on this center.

There is a groove around the hardened or tail stock center to distinguish it from the live or head spindle center.

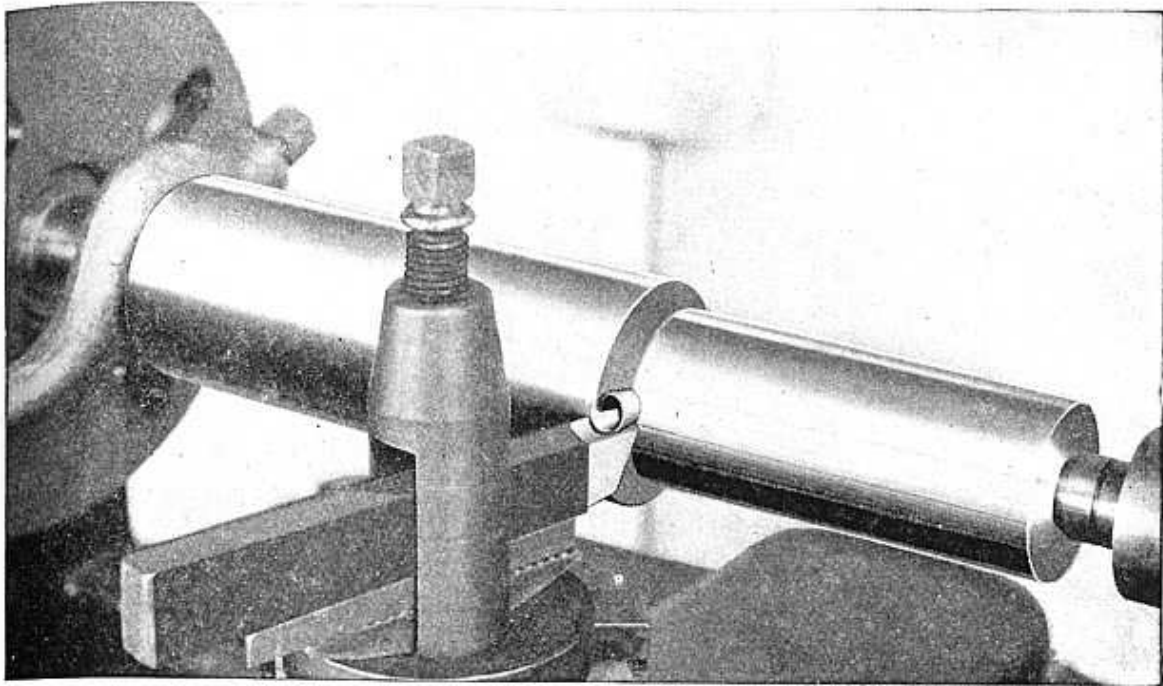

Fig. 467

ROUGH TURNING STEEL AND CAST IRON

Fig. 467 illustrates a lathe in operation taking a heavy cut, which is called rough turning. When a great deal of stock is to be removed from the work, heavy cuts should be taken in order to finish the job in the least possible time.

The proper tool should be selected for taking a heavy chip. The speed of the work, and the amount of feed of the tool should be as great as the tool will stand.

The work should be rough machined to almost the finished size, then care in measuring is required. It is at this point that the operator can demonstrate whether or not he has the ability to become an accurate workman.

CUTTING UNDERNEATH THE SCALE

When taking a roughing cut on steel or cast iron or any other metal that has a scale upon its surface, be sure to set the tool deep enough to get under the scale in the first cut, because unless you do, the scale on the metal will dull the point of the tool.

FINISH TURNING

When the work has been rough turned to within about $\frac{1}{32}$ " of the finished size, with a sharp keen tool take a finished cut. Caliper carefully to be sure that you are machining the work to the proper dimension.

On work where it is to be finished by a cylindrical grinder, a limited amount of stock is usually left for grinding to the finished dimensions.

THE DEPTH OF THE ROUGHING CHIP

The drawings below show the depth of a roughing cut on mild steel machined between centers on each size South Bend Lathe.

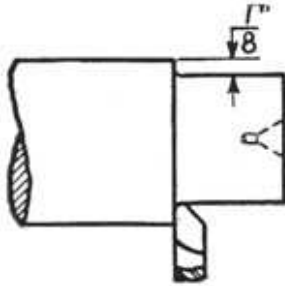

9" Lathe

Reducing the diameter $\frac{1}{4}$ " in one cut.

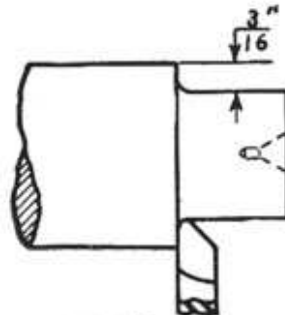

11" Lathe

Reducing the diameter $\frac{3}{8}$ " in one cut.

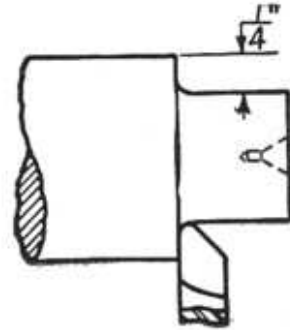

13" Lathe

Reducing the diameter $\frac{1}{2}$ " in one cut.

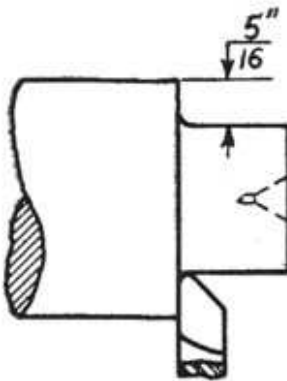

15" Lathe

Reducing the diameter $\frac{5}{8}$ " in one cut.

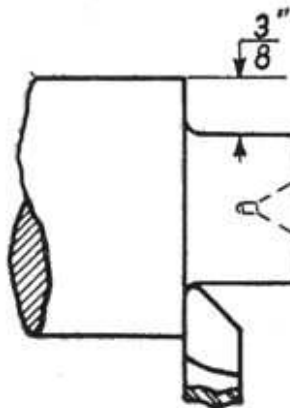

16" Lathe

Reducing the diameter $\frac{3}{4}$ " in one cut.

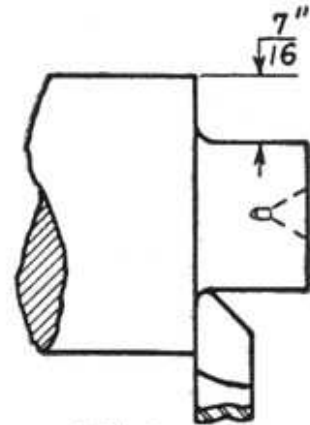

18" Lathe

Reducing the diameter $\frac{7}{8}$ " in one cut.

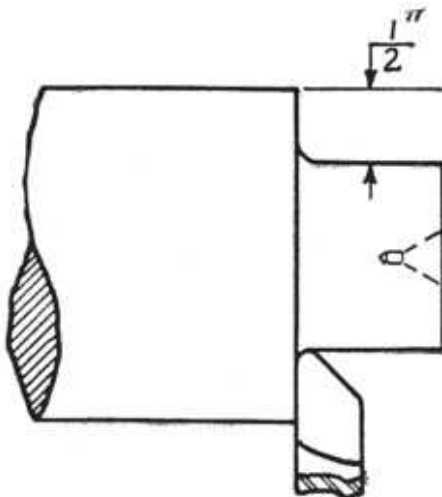

21" Lathe

Reducing the diameter 1" in one cut.

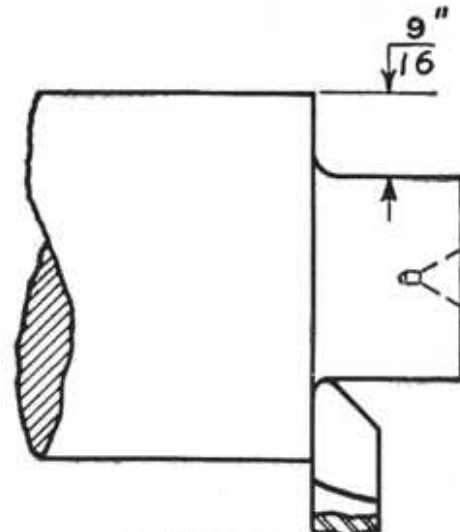

24" Lathe

Reducing the diameter $1\frac{1}{8}$ " in one cut.

THE CUTTING SPEED FOR DIFFERENT METALS

The following peripheral speed is recommended for cutting metals in the lathe when high speed cutting steel is used. All speeds are based on an average turning feed. F.P.M. indicates the Feet Per Minute periphery speed of the revolving work.

Material	F.P.M.	TURNING AND BORING		Cutting Screw Threads
		Heavy Cut	Finishing Cut	
Cast Iron	60	80	25	
Machine Steel	90	125	35	
Tool Steel, Annealed.....	50	75	20	
Brass	150	200	50	
Aluminum	200	300	50	
Bronze	90	100	25	

TO FIND THE CUTTING SPEED OF A REVOLVING PIECE OF WORK

To find the cutting speed of the revolving work, multiply the diameter of the work in inches by 3.1416 and multiply the product by the number of revolutions per minute the work rotates, and divide by 12, which will give the periphery speed in feet per minute.

Example: A piece of work 1" in diameter revolving 343.77 revolutions per minute, has a periphery or cutting speed of 90 feet per minute.

$$\frac{1 \times 3.1416 \times 343.77}{12} = 90 \text{ ft. per minute.}$$

NUMBER OF REVOLUTIONS REQUIRED FOR A GIVEN CUTTING SPEED

To find the number of revolutions required for a given cutting speed, in feet per minute, multiply the given cutting speed by 12 and divide the product by the circumference (in inches) of turned part.

Example: Find the number of revolutions per minute for 1" shaft for a cutting speed of 90 feet per minute.

$$\frac{90 \times 12}{3.1416 \times 1} = 343.77 \text{ R. P. M.}$$

SPEED INDICATOR WITH A SURFACE SPEED ATTACHMENT

Fig. 468 shows a speed indicator for determining the speed of revolving shafts in figuring the size of pulleys, etc.

The attachment shown on the speed indicator is pressed against the revolving work and it will indicate on the dial the number of linear feet per minute that the periphery of the work is traveling. This enables the workman to quickly find the proper cutting speed for the work.

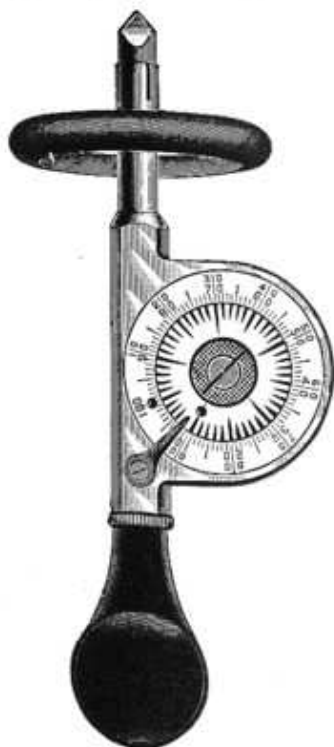
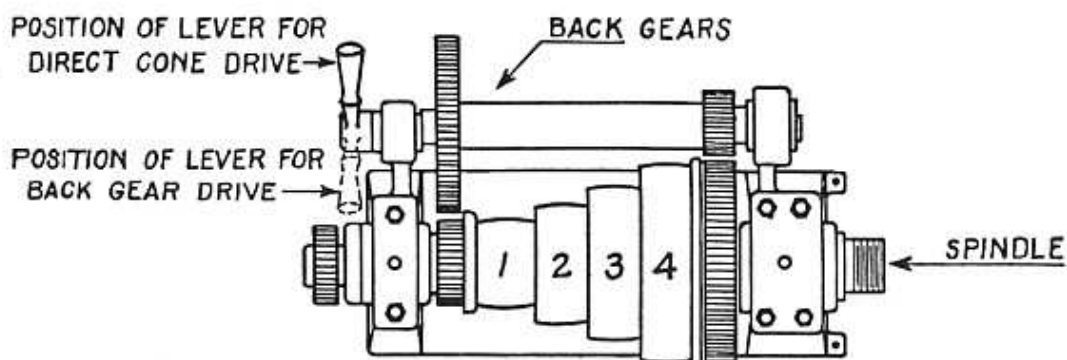

Fig. 468.—Speed Indicator



HEAD STOCK OF A SOUTH BEND LATHE

The drawing above shows the head stock of a lathe, the cone steps are numbered 1, 2, 3, and 4 according to size.

The table below shows the spindle speeds of each size South Bend Lathe when the countershaft is operated at the regular speed as indicated.

SPINDLE SPEEDS OF SOUTH BEND LATHES IN REVOLUTIONS PER MINUTE									
SIZE OF LATHE	COUNTER SHAFT SPEED	DIRECT CONE DRIVE				BACK GEAR DRIVE			
		1	2	3	4	1	2	3	4
9"	290	690	390	240	—	130	75	45	—
11"	290	595	360	230	—	100	60	40	—
13"	275	685	425	275	180	100	60	40	25
15"	250	660	395	250	160	95	58	36	22
16"	225	610	360	225	140	75	50	30	20
18"	200	465	300	200	135	70	45	28	18
21"	175	430	270	175	115	55	35	22	15
24"	150	355	225	150	100	40	25	16	10

If it is required to speed the spindle up for constant machining on copper or wood, where high speed is necessary, a two-speed countershaft can be used or one of the friction pulleys on the countershaft can be driven by a large size pulley on the lineshaft, and any speed desired can be obtained in this way.

FACING A JOB ON CENTERS

When accurate work is to be machined on centers, the first thing to do is to face the ends of the work. Not only to get the ends square and clean, but also to machine the work to the proper length.

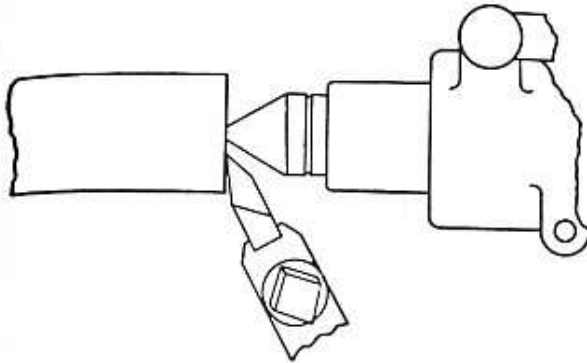

Fig. 469.—Facing a Steel Shaft

dog on the other end of the work and face it to the proper length.

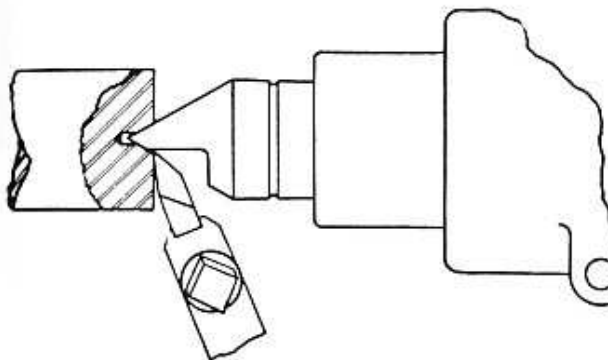

Fig 470.—Facing When Relieved Center Is Used

Fig. 469 shows the method of facing a cylindrical piece. The work is placed on centers and driven by a dog. A facing tool bit is then placed in the tool holder and a light cut is taken on the end of the work, feeding the tool from the center towards the outside. One or two chips are then taken, removing sufficient stock to true up the work. Place the

Facing the Work on a Relieved Center

Fig. 470 shows the method of facing the work when a relieved center is used in the tail spindle. Part of this center has been cut away so that it allows the edge of the tool to face the job from the diameter to the center hole. A relieved center is used when a quantity of small accurate pieces are to be faced.

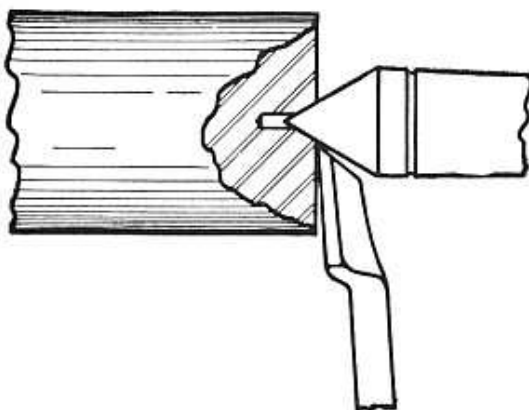

Fig. 471.—Facing with Forged Steel Side Tool

Facing with Forged Steel Side Tool

Fig. 471 shows the method of facing the end of the work by a forged steel side tool. The method of facing is about the same as in the above two examples. That is, the tool may be fed to the outside and also from the outside to the center.

Direction of Feed with a Job on Centers

In machining a job on centers in the lathe, the feed of the tool should always be, when possible, in the direction of the head spindle. The reason is obvious: When the carriage is feeding toward the head spindle and the tool making a heavy chip, the pressure is on the head center which revolves with the work.

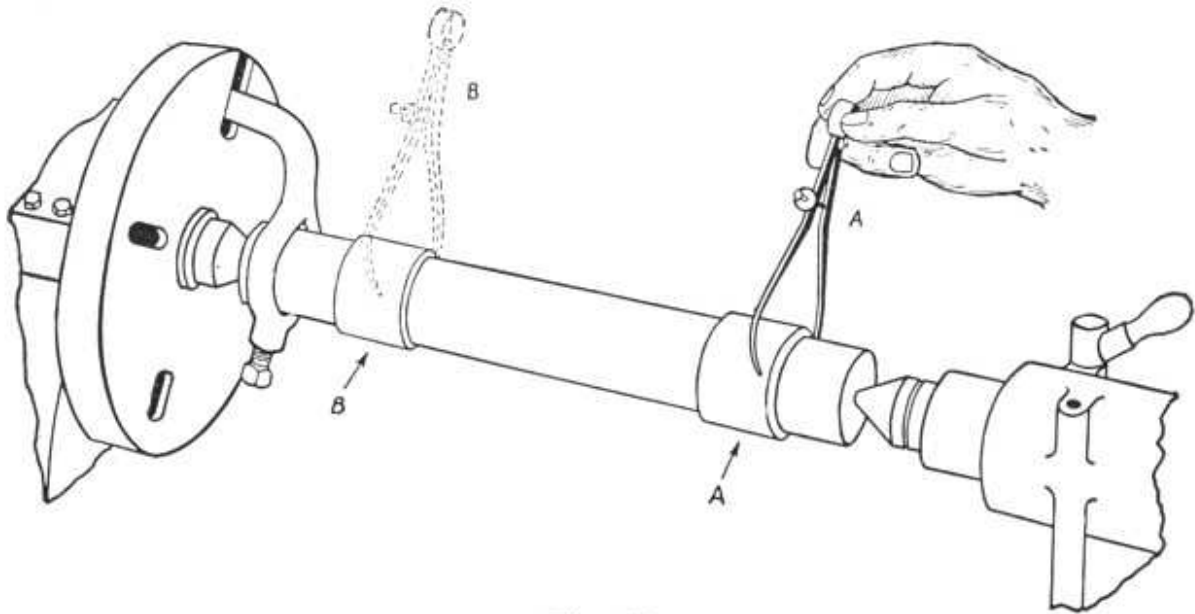

Fig. 472

TESTING THE ALIGNMENT OF CENTERS

Fig. 472 shows the method of testing for the alignment of the Lathe Centers. A steel or cast iron cylinder about $1\frac{1}{2}$ " in diameter has been centered and rough machined. Two collars, A and B, are machined with a fine finished chip without changing the position of the cutting tool. Collar A is calipered, and without making any adjustment on the caliper, collar B is calipered and tested to see how it compares with collar A. If collar A is not the same diameter as collar B, then the alignment of centers is not correct, and the tail stock center should be adjusted in the direction required. This is done by releasing one of the adjusting screws of the tail stock top and setting the opposite screw a similar distance. Then take another test chip on the collars. Continue this operation until the desired degree of accuracy is obtained.

Tail Stock Top and Bottom Mark

There is a mark on the head end of the tail stock where the bottom and top join, which marks the relative position of the tail stock top and bottom when the tail center is in line with the head center. For fine accurate work, this mark should not be depended upon, but the test should be made as above described to be sure that the centers are in line.

If, while making the above test for alignment of centers, it is found that the head center or tail center is blunt or worn, or out of true, then this test is useless, because to do accurate work, lathe centers must not only be aligned properly, but must also be in perfect condition.

Suggestions

In making test for alignment of centers, it is not necessary that the test piece have two collars, as the same test could be made on a straight cylinder, but a test bar like that shown in the above drawing is a very good thing to have around the shop for testing alignment of centers.

MACHINING TO A SHOULDER

Machining to a shoulder in production work, where a quantity of pieces are required, is usually started by using the parting tool. The object is to locate the position of the shoulder, and to consider the smaller diameter of the work. The parting tool is inserted about $\frac{1}{2}$ of an inch back of the shoulder line, and enters the work within $\frac{1}{2}$ of an inch of the smaller diameter of the work. Then the stock may be machined by heavy chips. Shouldering eliminates detailed measuring, speeds up production, reduces the cost of machining, and avoids mistakes and spoiled work.

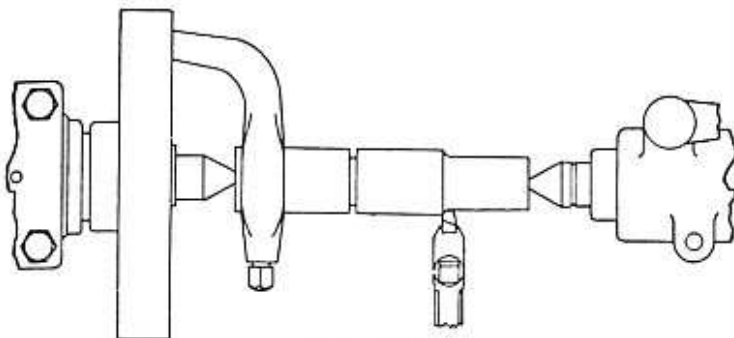

Fig. 473

The Use of the Parting Tool

Fig. 473 illustrates the method of shouldering. A Parting tool has been used, and the turning tool is taking a chip. It will be unnecessary for the operator to waste any time in taking measurements. He can devote his time to rough machining until the necessary stock is removed. Then he can take a finishing cut to accurate measurement.

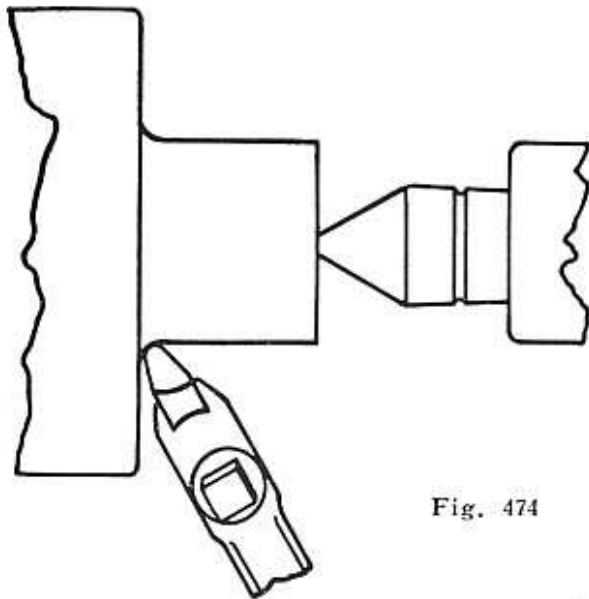

Fig. 474

Facing a Shoulder

Figure 474 shows the application of a finishing of a shouldered job having a fillet corner. A finish cut is taken on the small diameter. The fillet is machined with a light cut, then the tool is used to face from the fillet to the outside diameter of the work.

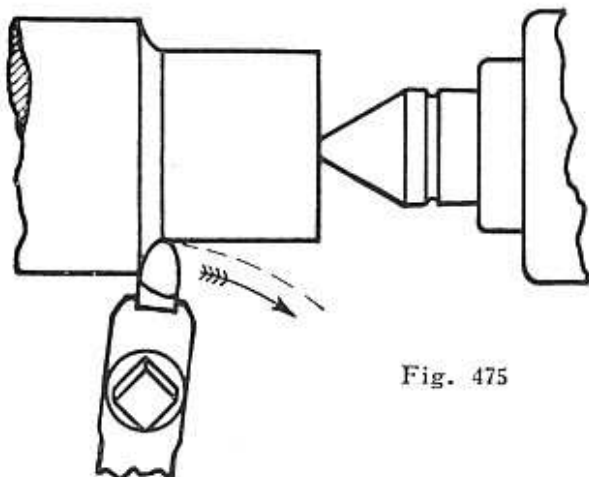

Fig. 475

The Position of the Turning Tool on Heavy Work

Fig. 475 shows the position of the turning tool taking a heavy chip on large work.

The tool should be set so that if anything occurs while machining to change the position of the tool, it will not dig into the work, but rather it will move in the direction of the arrow—away from the work.

Setting the tool in the above position sometimes prevents chatter.

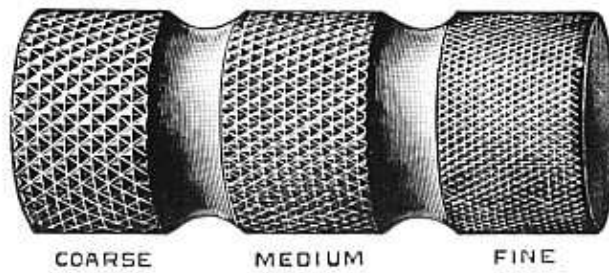

Fig. 476.—Sample of Knurling

KNURLING IN THE LATHE

Fig. 476 shows three examples of knurling on a piece of steel. The pattern of the knurl is alike in all three cases but of different grades, one is called coarse, another medium, and another fine grade of knurling.

KNURLING TOOL

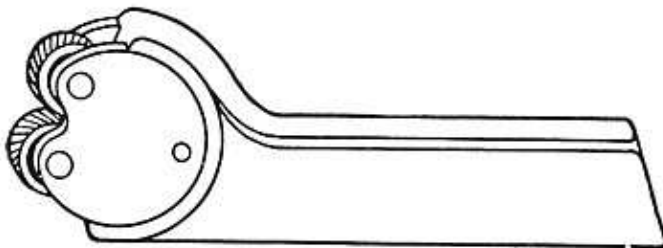

Fig. 477.—Knurling Tool

Fig. 477 illustrates a form and design of a knurling tool that is used in the tool post of the lathe. The knurling rollers shown in this tool are removable and any grade, fine or coarse, can be substituted to get any grade knurl desired.

KNURLING TOOL IN OPERATION

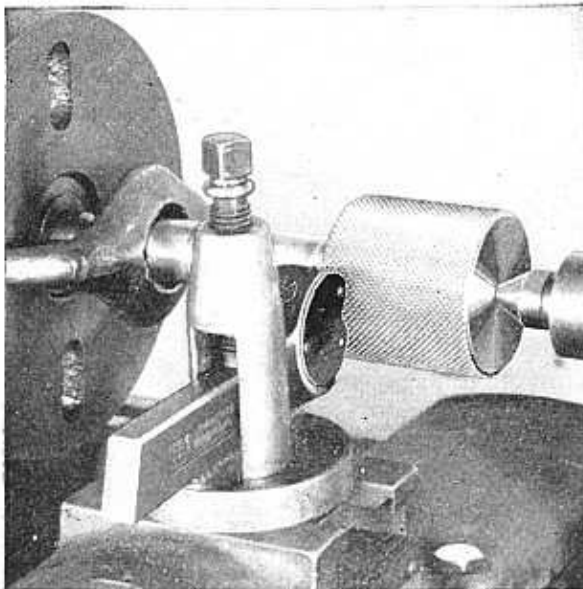

Fig. 478.—Knurling a Steel Piece

Fig. 478 shows a knurling tool in operation on work driven between centers on the lathe.

To knurl the work, start lathe slowest speed back gear and force the knurling tool slowly into the work at the right end until the knurl reaches a depth of about $\frac{1}{64}$ ". Set the longitudinal feed of the carriage and let the knurling tool feed across the face of the work. Plenty of oil should be used on the work during this operation.

When the left end of the knurl roller has reached the end of the work, reverse the shipper rod. This will reverse the feed of the carriage and the direction of rotation of the spindle. Do not remove the knurling tool from the impression but force it into the work another $\frac{1}{64}$ ", and let it feed back across the face of the work. Repeat this operation until the knurling is finished.

MACHINING WORK ON A MANDREL BETWEEN CENTERS

Cylindrical work that has been bored and reamed in a chuck is usually further machined on a mandrel between centers in the lathe. The mandrel must be driven into the hole of the work tight enough so that the work will not slip on the mandrel while it is being machined on centers in the lathe.

Before driving the mandrel into the hole in the work, with a drop of oil on the finger moisten the fitting part of the mandrel so that after it is driven into the work and the work finished it will be easy to remove the mandrel. If there was no lubricant on the mandrel it might freeze in the work, in which case it cannot be driven out without ruining both the work and the mandrel.

In driving a mandrel out of a piece of work be sure that it is driven in the opposite direction from that which it entered the work.

In the case of special jobs, where no reamers are available, a soft mandrel may be used, turning and filing it to the proper diameter and tapered to make a driving fit for the hole in the work.

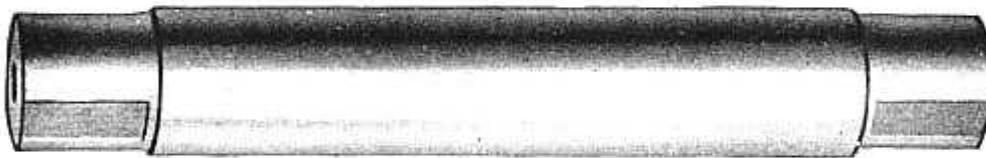

Fig. 479.—Steel Lathe Mandrel

The steel lathe mandrels can be purchased in the various standard sizes. These mandrels are hardened and tempered and the surface that receives the work is ground usually to a taper of about .003" from one end of the ground surface to the other. Therefore, these mandrels fitting to the work are driven in, small end of the taper first.



Fig. 480.—An Expanding Mandrel

Fig. 480 shows a practical expanding mandrel. The mandrel itself is machined and has a taper about $\frac{1}{2}$ " to the foot. A taper sleeve having the same internal taper is then fitted to the mandrel. This taper sleeve has a number of slits made by a saw so as to allow an expansion. See illustration.

For using the expanding taper mandrel, imagine you are to machine a pulley. Place the taper sleeve in the hub of the pulley and drive the taper mandrel in the sleeve until it expands the taper sleeve and securely holds the pulley, then place the job between centers on the lathe and start machining.

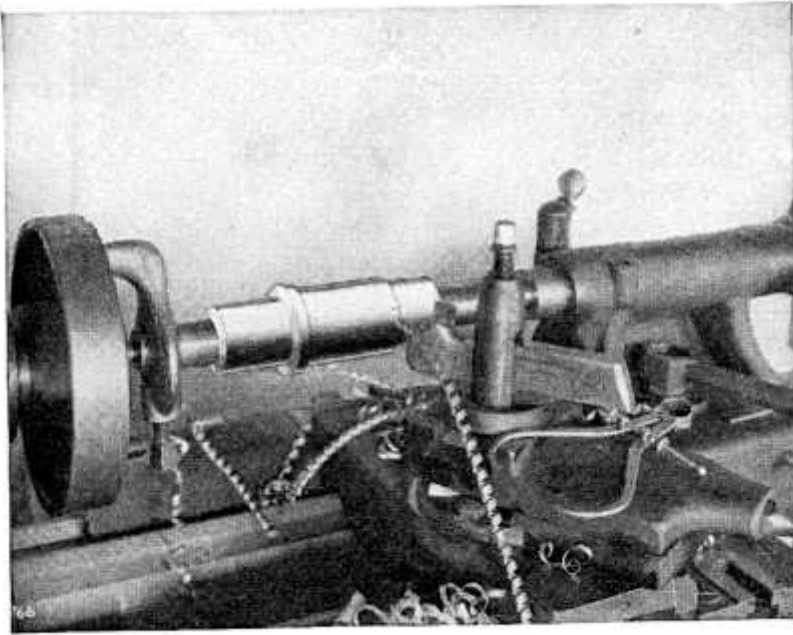

Fig. 481

Fig. 481.—Machining a steel sleeve held on a mandrel and driven between centers.

Fig. 482.—Machining a job on a mandrel between centers, using three cutting tools.

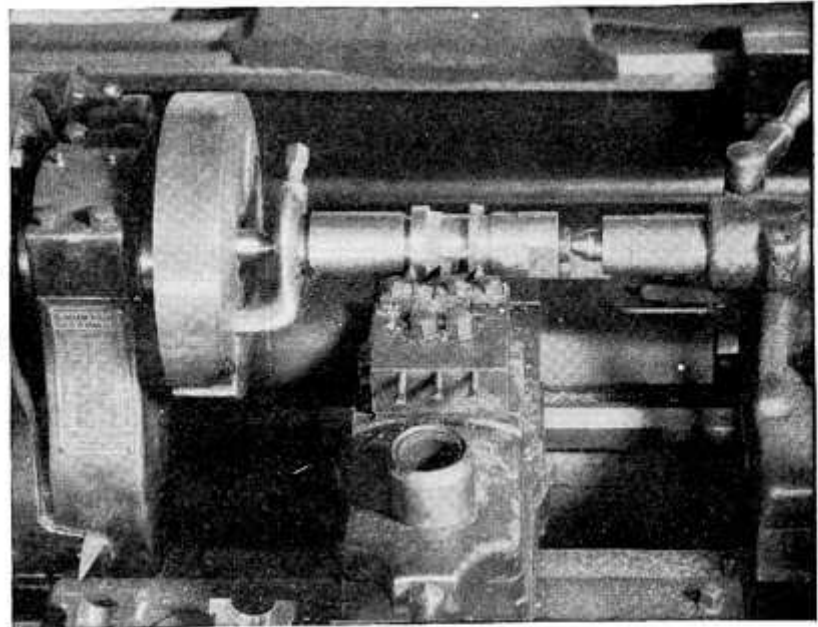

Fig. 482

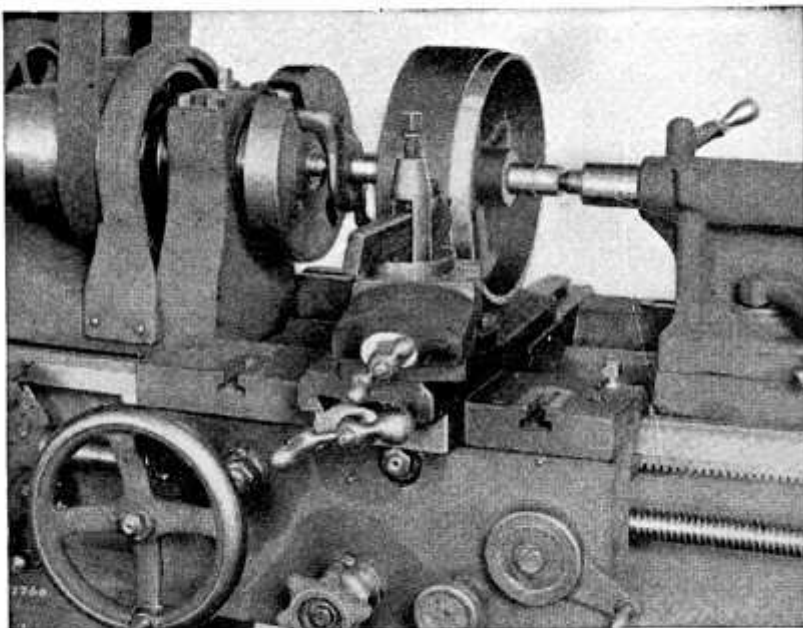

Fig. 483

Fig. 483.—Machining a cast iron pulley held on a mandrel and driven between centers

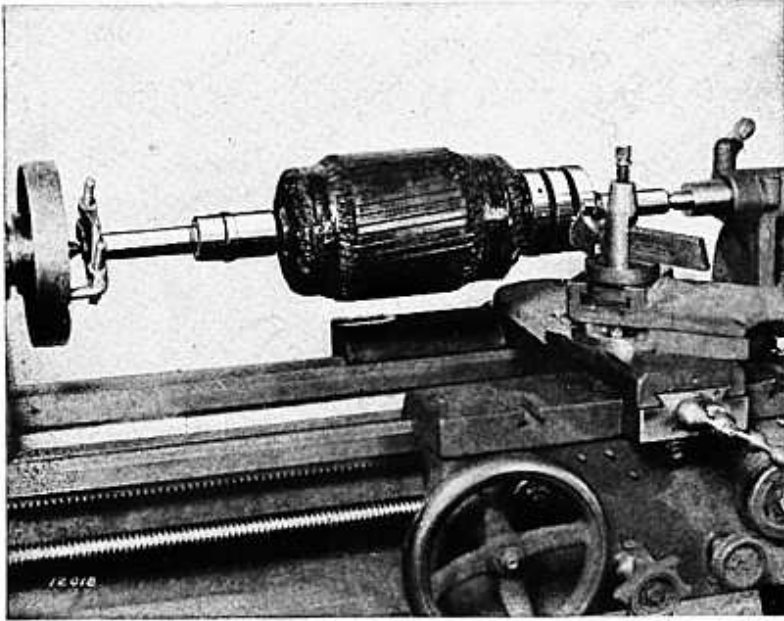

Fig. 487

Fig. 487.—Machining a Slip Ring armature commutator between centers. A direct current armature commutator can be machined in the same way.

Fig. 488.—Two cutting tools in operation on a manufacturing job that is driven on centers in the lathe.

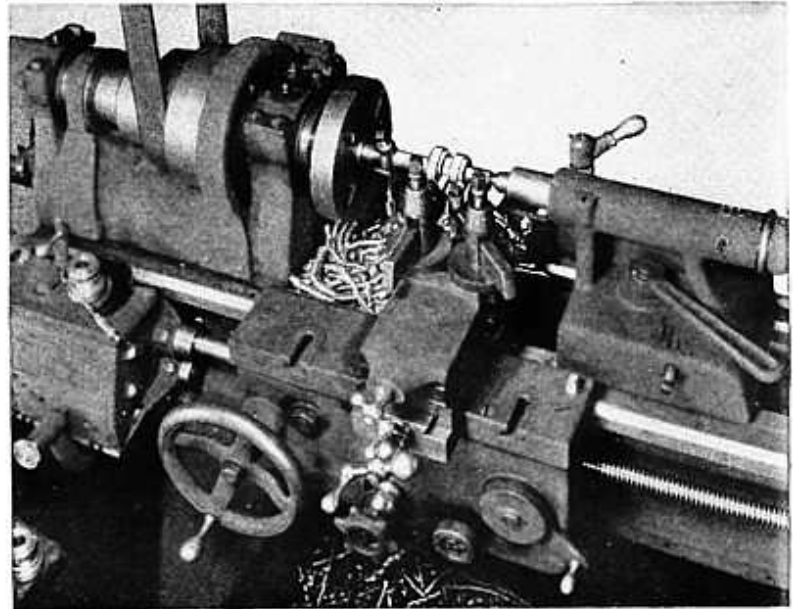

Fig. 488

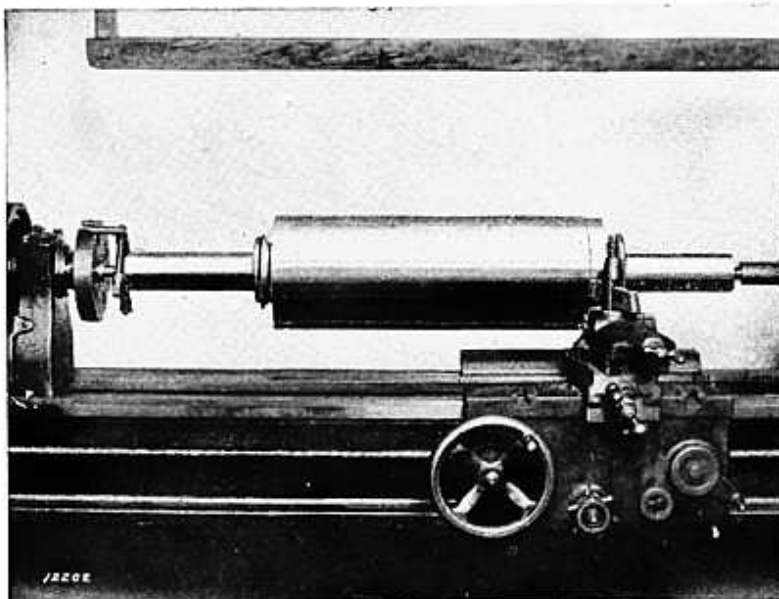

Fig. 489

Fig. 489.—Finishing chip being taken on a printers' roll that is driven between centers on the lathe.

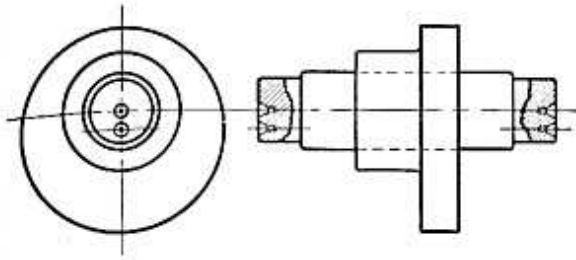

Fig. 490

Fig. 490.—An eccentric cam driven on an arbor with two pair of countersunk center holes, one pair of which is for concentric machining and the other pair for eccentric machining.

Fig. 491.—Machining a crankshaft of a gasoline engine on centers. The cast iron dogs are fastened by set screws to each end of the shaft. These dogs have a pair of countersunk center holes that line up with the throw of the crank.

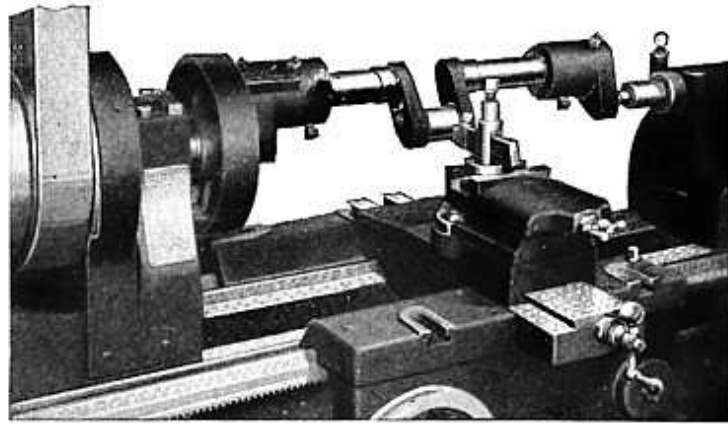

Fig. 491

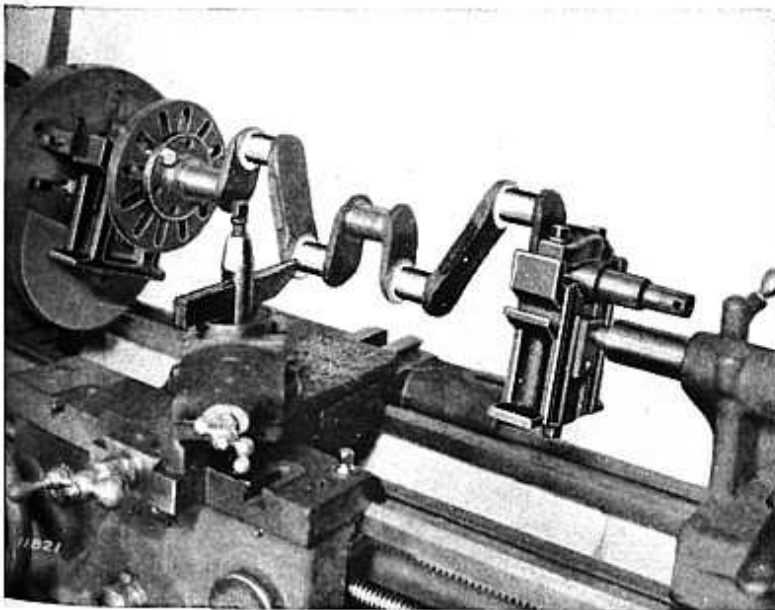

Fig. 492

Fig. 492.—Application of the Norton Adjustable Throw Centers for aligning an automobile crank shaft to machine any of the bearings between centers on the lathe.

THE USE OF A CENTER REST ON THE LATHE

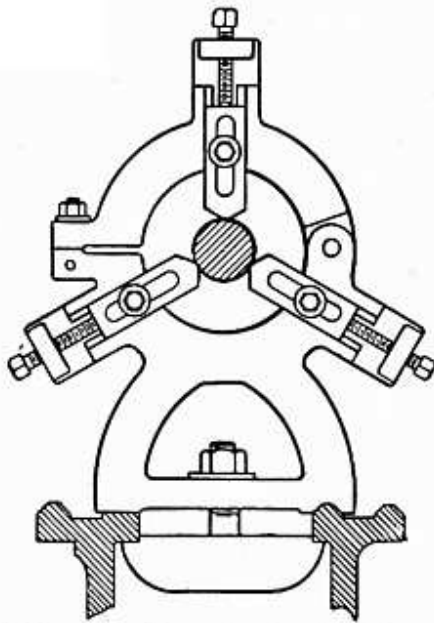

Fig. 493.—The Center Rest on the Lathe

In turning long shafts of small diameter, and for boring and threading spindles, it is necessary to support the work while it is being machined. This is accomplished by using a center rest.

Fig 493 shows the end view of a center rest that is attached to the lathe bed. The illustration shows a cylinder or shaft being held in the center rest.

MOUNTING WORK IN THE CENTER REST

To mount work in the center rest, place the center rest on the lathe. Place the work between centers, slide the center rest to its proper position, and adjust the jaws upon the work. Careful adjustment is required because the work must revolve in these jaws. When the work is centered properly, so that it revolves freely, clamp the jaws in position, fasten the work to the head spindle of the lathe, slide the tail stock out of the way and the work is ready for machining.

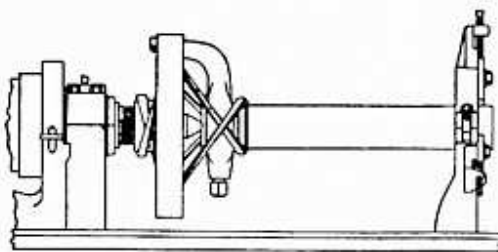

Fig. 494.—Fastening the Work to the Head Spindle

TYING THE WORK TO THE HEAD SPINDLE

Fig. 494 shows the method of fastening the work to the head spindle. The face plate is unscrewed from the shoulder about three or four turns. Then the work is placed on center and tied securely to the face plate with several heavy belt laces, and finally the face plate is screwed on to the shoulder of the spindle. This tightens the lacing on the work, and holds it firmly.

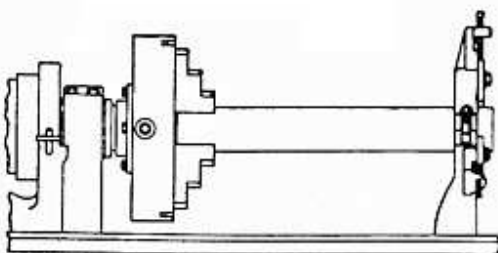

Fig. 495.—The Chuck and the Center Rest

HOLDING THE WORK IN A CHUCK AND CENTER REST

Fig. 495 shows the work, one end being located on the center rest, the other end being held in a 3-jaw Universal Chuck on the spindle of the lathe. For fine accurate work such as turning and boring the taper on spindles for the drill press or the lathe, the chuck should not be used, but the center method used as shown in Fig. 494.

THE FOLLOWER REST ON THE LATHE

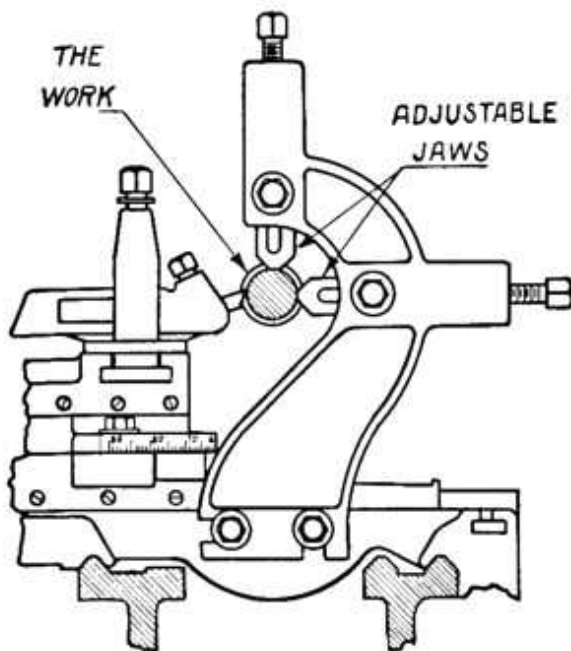

Fig. 496.—The Follower Rest

Fig. 496 shows the application of a follower rest, which is attached to the saddle of the lathe for machining work of small diameter that is liable to spring if it had no support.

The adjustable jaws of the follower rest bear directly on the finished diameter of the work, following the cutting edge of the tool on the opposite side of the work. As the tool feeds along the work, the follower rest being attached to the saddle travels with the tool.

For the machining of small shafts in quantity, small rollers are sometimes substituted for the

rigid adjustable jaws and the device is then known as the Roller Bearing Follower Rest.

THE USE OF THE CENTER REST AND THE FOLLOWER REST COMBINED

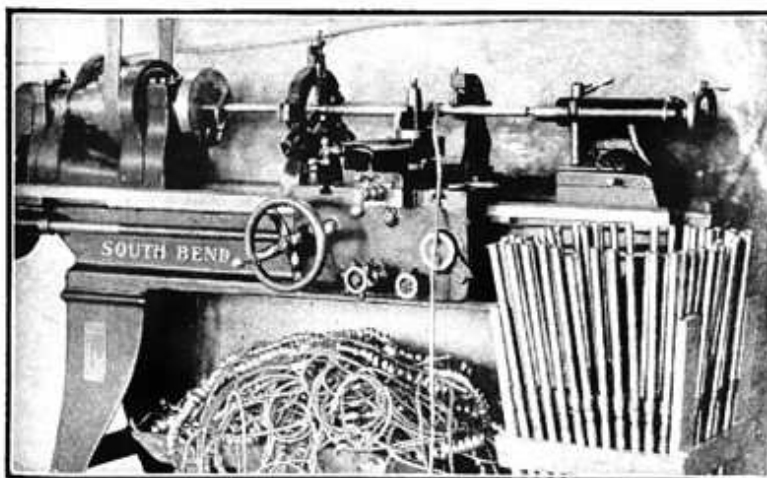

Fig. 497.—Center Rest and Follower Rest on a Job

Fig. 497 shows the application of both the center rest and follower rest on a job at the same time. The spindles or shafts to be machined, while very small in diameter, are of considerable length, and in order to do a good job, it is necessary to support the shaft with both the center rest and follower rest.

This is the method of machining the small, delicate spindles used in textile mills.

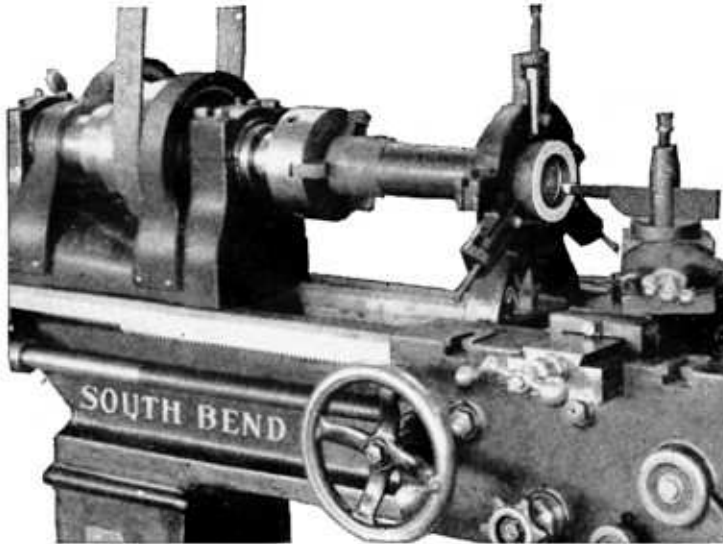

Fig. 498

Fig. 498.—Cutting an internal screw thread in a cylinder, one end of which is held in the center rest, the other end held in a 3-Jaw Universal Chuck on the head spindle.

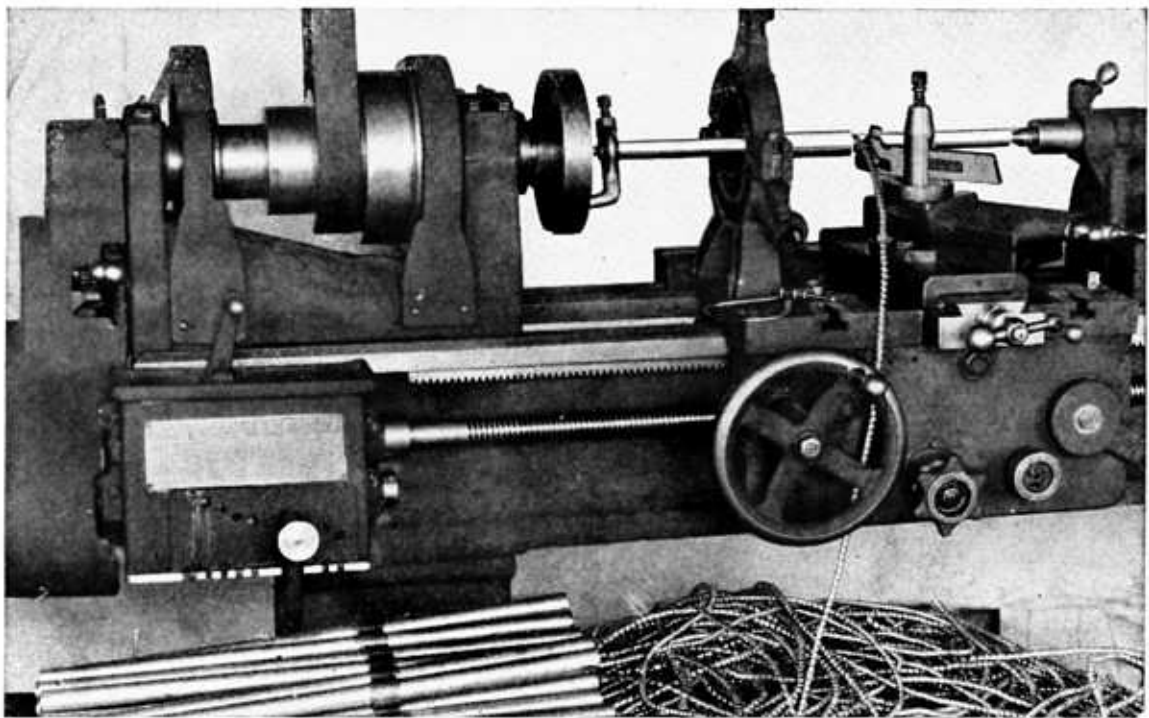

Fig. 499

Fig. 499.—The application of a Center Rest on machining small, slender shafts between centers on the lathe.

Fig. 500.—The application of the follower rest supporting long, slender Acme Thread Screw, while the thread of the screw is being chased by the tool.

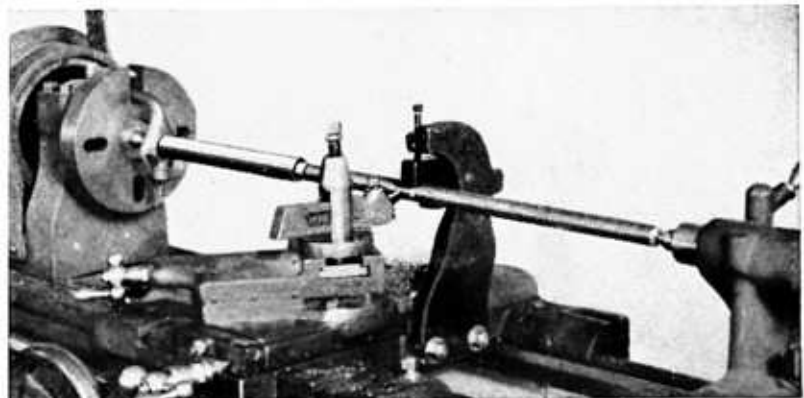

Fig. 500

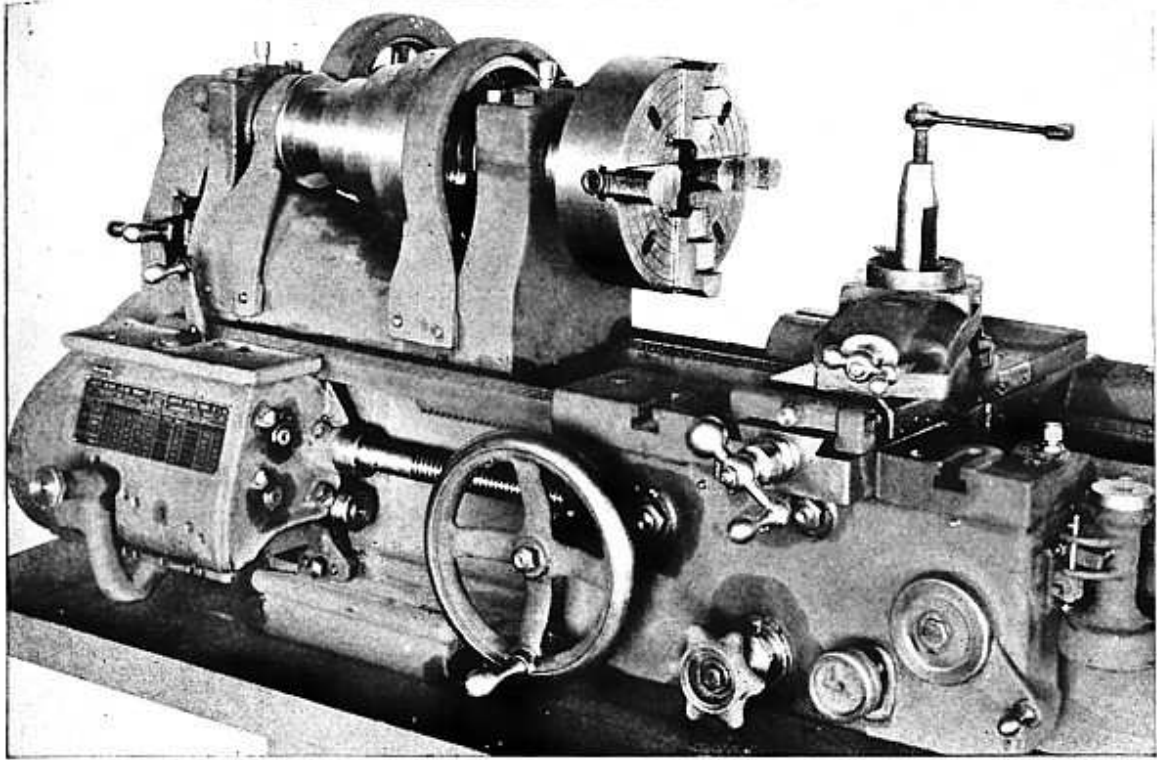

Fig. 501

MACHINING IN THE CHUCK ON THE LATHE

Chucking in the lathe is a very important part of lathe work, especially for general work in the machine shop.

Fig 501 shows a 4-jaw Independent Lathe Chuck mounted on the spindle nose of the lathe. The most important types of lathe chucks are the Independent Lathe Chuck and the Universal Geared Scroll Chuck.

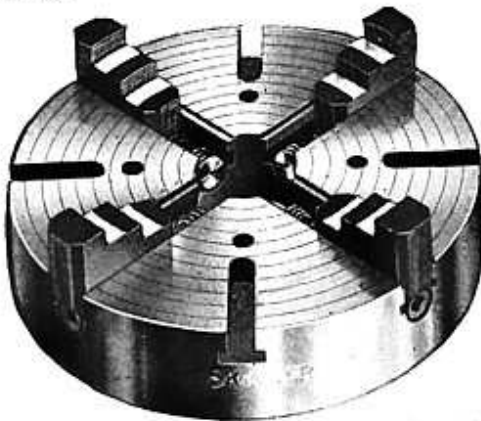

Fig. 502.—4-Jaw Independent Lathe Chuck

Four-Jaw Independent Lathe Chuck

Fig. 502.—The 4-jaw Independent Lathe Chuck is the most practical for general work in the machine shop. The jaws are made of steel, hardened and ground. They are reversible and are readily adjusted to hold work square or round and of various shapes. The jaws are adjusted one at a time.

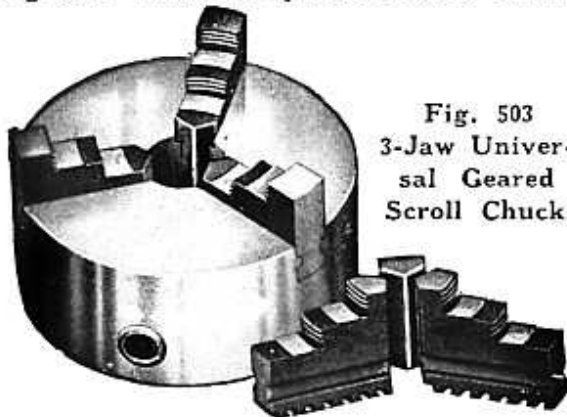

Fig. 503
3-Jaw Universal
Geared
Scroll Chuck

Three-Jaw Universal Geared Scroll Chuck

Fig. 503.—The 3-jaw Universal Geared Scroll Chuck is intended for holding round work. The jaws operate universally and center the work. This chuck is usually fitted with two sets of jaws, both of which are shown in the illustration.

THE PRACTICAL TYPE OF CHUCK FOR THE LATHE

If the lathe is to have but one lathe chuck, it should be a 4-jaw Independent chuck, because it will hold work both rectangular and round, and various other shapes.

If the lathe is to be fitted with two chucks, then the Universal Geared Scroll Chuck should be used in addition to the Independent Chuck, because this enables the operator to handle a great deal of round work without time being spent for continually truing up the work, as the Universal Chuck is self centering.

THE SIZE OF THE LATHE CHUCK

The 4-jaw Independent Chuck should be as large as the lathe will swing with the chuck jaws extended beyond the body. The size of the Universal Chuck should be much smaller, as it is for holding round work, and great capacity is not needed. In the tabulation we show the approximate size chuck, both the Universal and Independent, for each size lathe. The tabulation has been based on chucks to meet the requirements for general work in the machine shop.

SIZE OF CHUCKS FOR A LATHE

	Universal Chuck	Independent Chuck
9" Lathe, size of chuck.....	4"	6"
11" Lathe, size of chuck.....	5"	6"
13" Lathe, size of chuck.....	6"	8"
15" Lathe, size of chuck.....	7 1/2"	9"
16" Lathe, size of chuck.....	9"	10"
18" Lathe, size of chuck.....	10 1/2"	12"
21" Lathe, size of chuck.....	12"	14"
24" Lathe, size of chuck.....	15"	15"

The chuck manufacturers make chucks so that they can be fitted to any size or make of lathe. Every chuck has a machined recess on its back to accommodate a chuck plate, the flange of which fits the chuck recess and the hub part is threaded to fit the spindle nose of the lathe.

The 4-jaw Independent Lathe Chuck is made in sizes from 4" to 24", but for practical work in the machine shop the popular sizes are from 6" to 18" inclusive, and for the Universal Chuck from 4 1/2" to 12" inclusive.

MISTAKES!

We all make mistakes. When you make a mistake on a piece of work correct and report it as soon as possible. Do not let it get by. People who shrink from letting mistakes be known for fear it will react on them only make matters worse by so doing.

CHUCK PLATE THREADED TO FIT SPINDLE NOSE OF LATHE

Fig. 504.—Semi-Machined Chuck Plate, threaded to fit the spindle nose of the lathe

Fig. 504 shows a cast iron semi-machined chuck plate that has been threaded to fit the spindle nose of the lathe. The chuck plate is not included in the equipment of the lathe. It is not only threaded to fit the spindle nose, but it is also machined on the front and back faces and there is enough stock on the diameter of the flange so that it may be turned down and fitted to the recess in the back of the lathe chuck.



Fig. 505.—Rear view of the Lathe Chuck

Fig. 505 shows machined recess in the back of a lathe chuck.

The machined recess in the back of the chuck is to receive the chuck plate. This machined recess is accurate so that when the chuck is fitted to the lathe it will run true. The small holes shown in the recess of the chuck are for bolting the chuck plate to the chuck.

For machining chuck plate, see page 64.

DRILLING HOLES IN THE CHUCK PLATE TO RECEIVE THE BOLTS

Fig. 506.—Chuck with Chuck Plate attached

Chalk the face of the flange of the chuck plate. Then place it in the recess of the chuck. When it is bottomed, make a prick punch position mark on the edge of the chuck plate and a corresponding mark on the chuck. Then with a hammer tap slightly the chuck plate so that the edge of the bolt holes on the recess of the chuck will make an impression on the chalk surface of the plate. Lay out and drill the holes in the plate $\frac{1}{16}$ " larger than the diameter of the bolt.

MACHINING A CAST IRON CHUCK PLATE

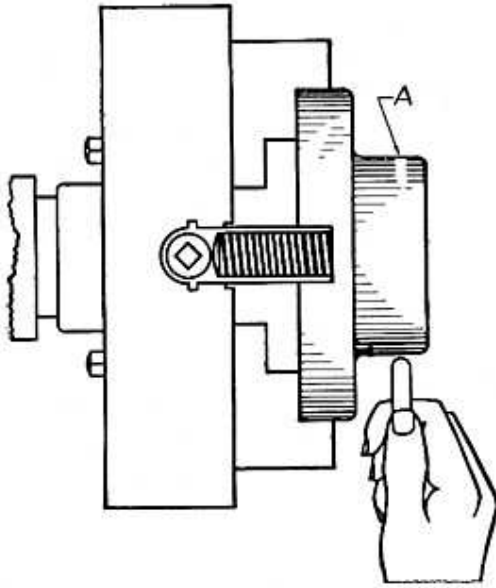

Fig. 507.—Truing a rough casting of a Chuck Plate

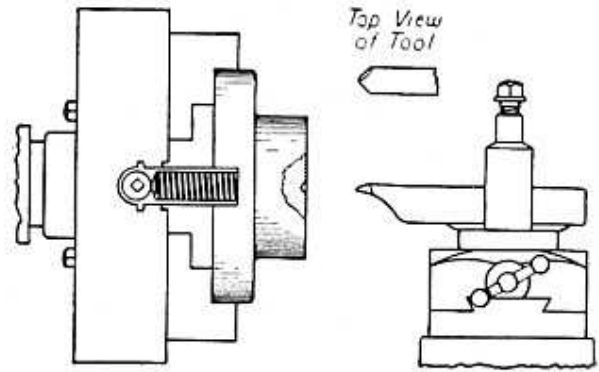

Fig. 508.—Centering a Chuck Plate

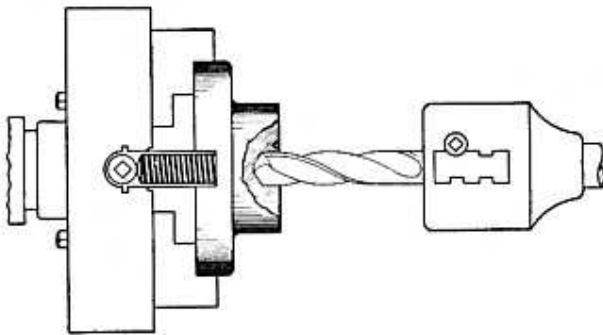

Fig. 509.—Drilling a Chuck Plate

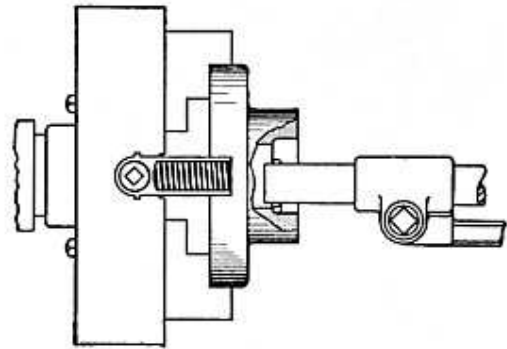

Fig. 510.—Boring a Chuck Plate

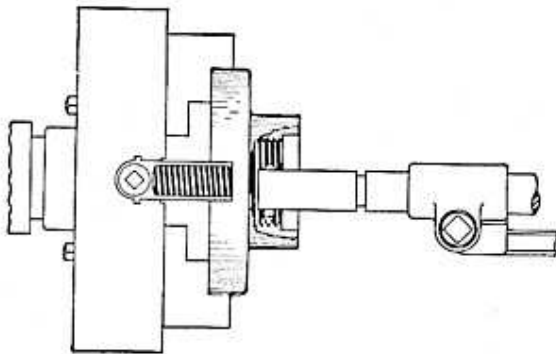

Fig. 511.—Threading a Chuck Plate

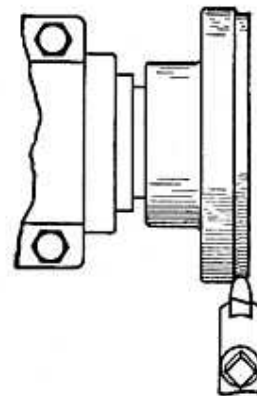

Fig. 512.—Turning the diameter of the flange of the Chuck Plate on the spindle of the lathe

MACHINING THE EDGE OF A CORED HOLE SO THAT DRILL WILL START TRUE

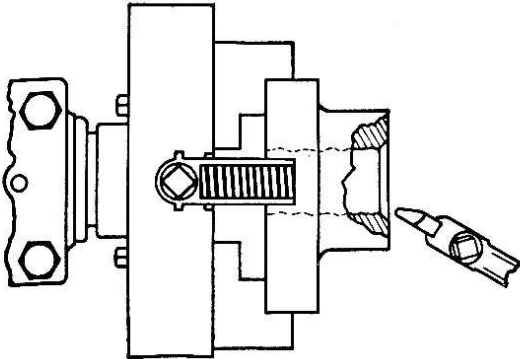

Fig. 513.—Machining the Edge of Cored Hole

Fig. 513 shows an irregular casting being held in a 4-jaw chuck to be machined. The casting has a cored hole which is being beveled with a chamfering tool, which gives it a machined surface that will start a shell drill true.

DRILLING A CASTING HAVING CORED HOLE

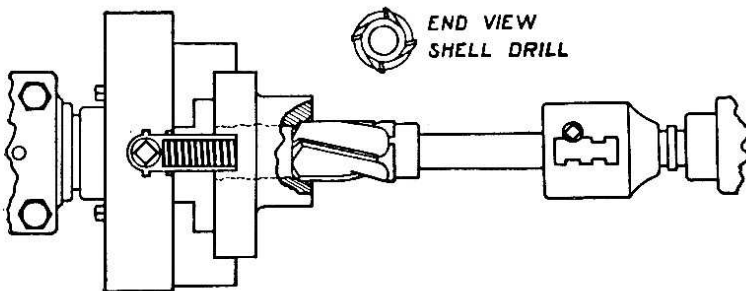

Fig. 514.—Drilling a Cored Hole

Fig. 514.—A shell drill is held in the drill chuck in the tail stock and is fed into the work. The beveled machined surface gives the shell drill an opportunity to center itself and the result is an almost perfect hole.

MACHINING SHORT JOBS IN THE UNIVERSAL CHUCK

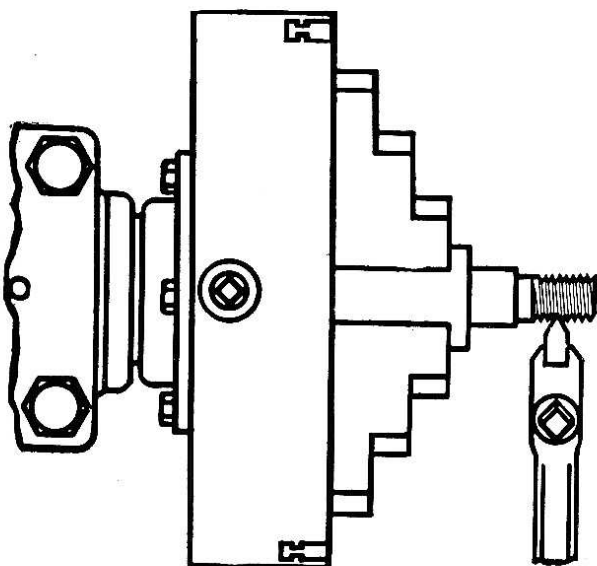

Fig. 515.—Thread Cutting in the Chuck

Fig. 515 illustrates the method of making a small cap screw in the chuck. The drawing shows that the work has been turned, shouldered and threaded. The next operation is the use of a cutting off tool.

A great deal of short work can be done in the chuck in this manner in much quicker time than could possibly be done by centering the work and machining between centers.

MOUNTING WORK IN A FOUR JAW INDEPENDENT LATHE CHUCK

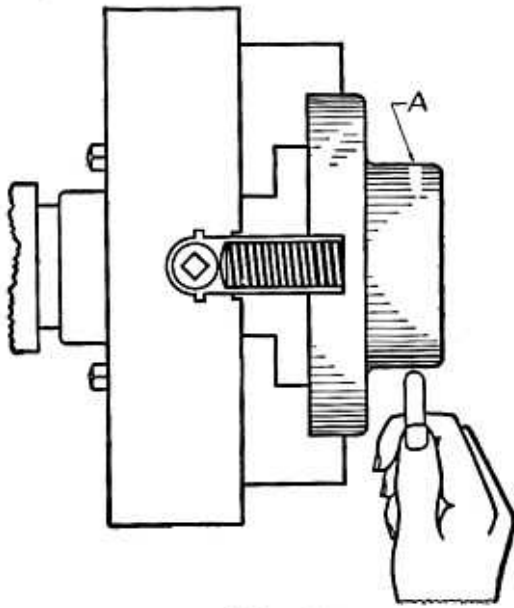

Fig. 516

Fig. 516 shows a rough casting of a chuck plate mounted in a 4-jaw Independent Lathe Chuck on the spindle of the lathe. Before truing the work, determine which part you wish to have run true. To mount this casting in the chuck proceed as follows:

1. Adjust the chuck jaws to receive the casting. Each jaw should be concentric with the ring marks indicated on the face of the chuck. If there are no ring marks, be guided by the circumference of the body of the chuck.

2. Fasten the work in the chuck by turning the adjusting screw on Jaw No. 1 and Jaw No. 3, a pair of

jaws which are opposite each other. Next tighten jaws No. 2 and No. 4.

3. At this stage the work should not be held in the jaws too tightly, but with just enough grip to hold the work securely so it will not fall out of the chuck while being trued up.

4. Revolve the spindle slowly and with a piece of chalk mark the high spot on the work while it is revolving.

5. Stop the spindle, locate the high spot on the work and adjust the jaws in the proper direction to true the work; releasing the jaw opposite the mark on the work and tightening the one next the mark.

6. Sometimes the high spot on the work shows that an adjustment is needed midway between two jaws. In this case loosen the two jaws, one of each pair, and tighten the opposite jaws.

7. When the work is running true in the chuck, tighten each jaw, one after another in sequence, until all four jaws are clamping the work securely. Be sure that the back of the work rests against the face of the four jaws.

When the work consists of a number of duplicate parts that are to be machined in the chuck, release two adjacent jaws and remove the work. Place another piece in the chuck and tighten the two jaws just released.

Each jaw of a lathe chuck, whether an Independent or a Universal Chuck, has stamped on it a number to correspond with a similar number on the chuck, because each jaw fits only its own screw and slot in the chuck, so that when you remove a chuck jaw for any reason you should always put it back into its proper slot and screw.

When the work to be chucked is frail or light, the jaw should be fastened carefully so that it will not bend, break, or spring the work.

In chucking rings, cylindrical dies, etc., the work can be held from the inside with the jaws pressing outward.

Never leave a chuck wrench in a chuck while the chuck is on the spindle of the lathe.

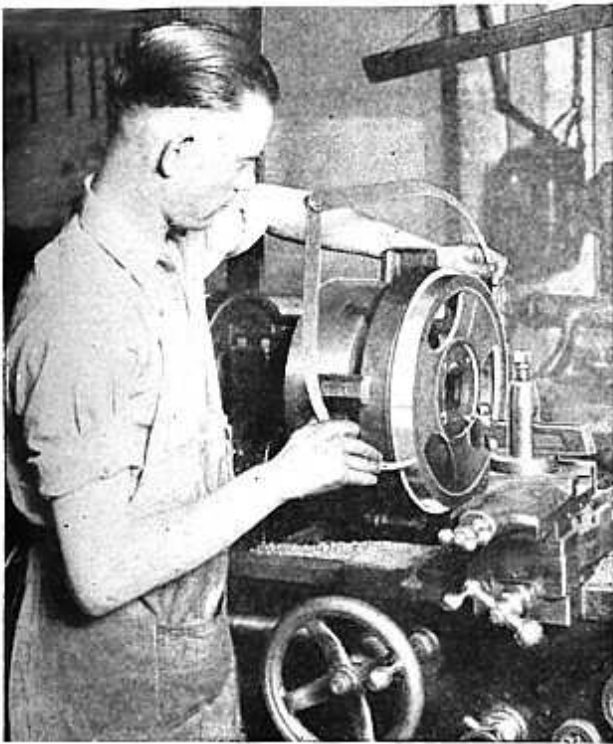

Fig. 526

Fig. 526.—Shows a Fly Wheel being chucked in a 4-Jaw Independent Chuck, one end of the Fly Wheel being machined to receive a ring gear.

Fig. 527.—Cutting an internal thread on a cast iron pole base while being held in a 4-Jaw Independent Chuck.

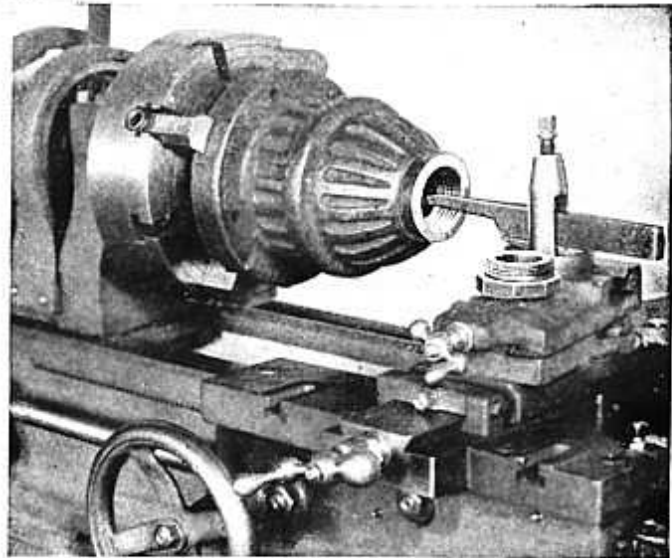

Fig. 527

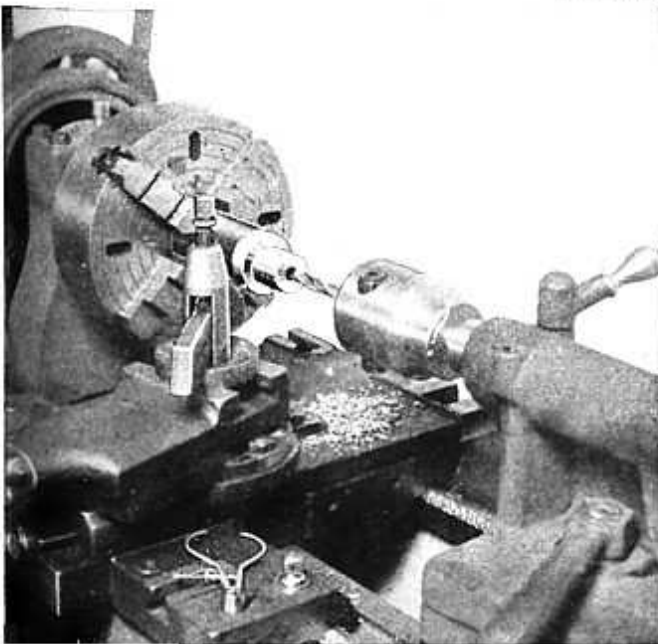

Fig. 528

Fig. 528.—Making a bushing, showing the application of a lathe chuck on the head spindle and the drill chuck on the tail spindle of the lathe.

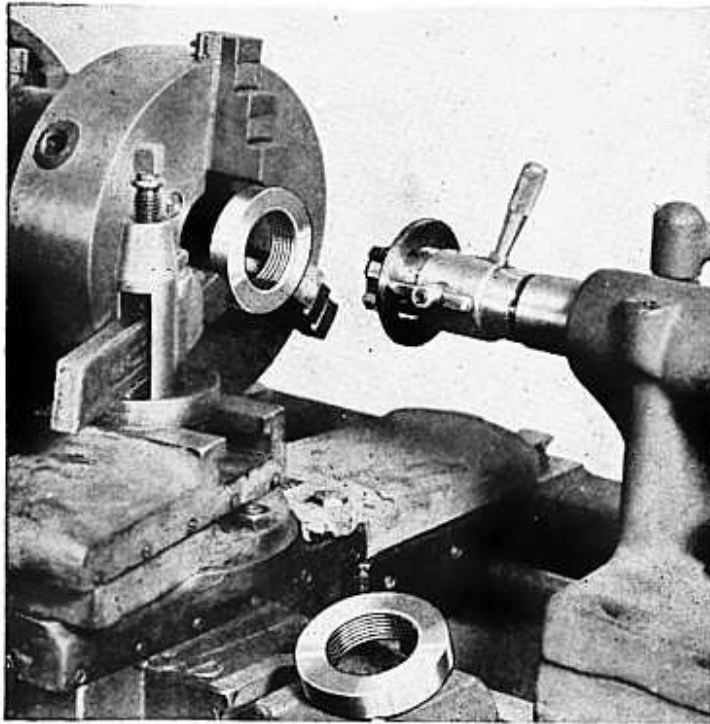

Fig. 529

Fig. 530.—Threading a cap screw. A self opening die head is held in the tail stock spindle which is fed to the work.

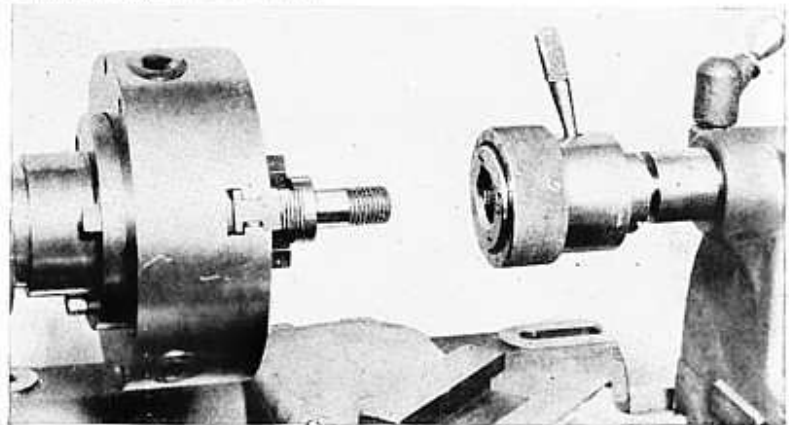

Fig. 530

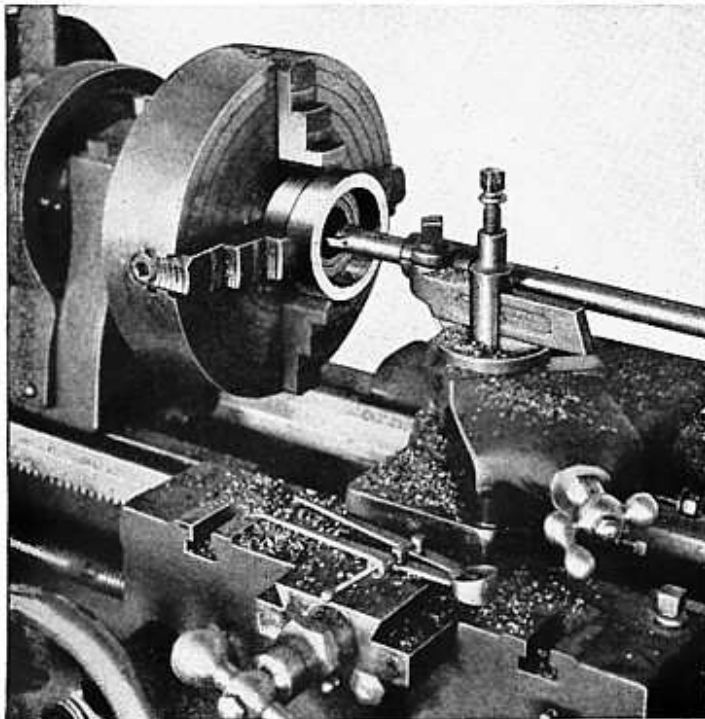
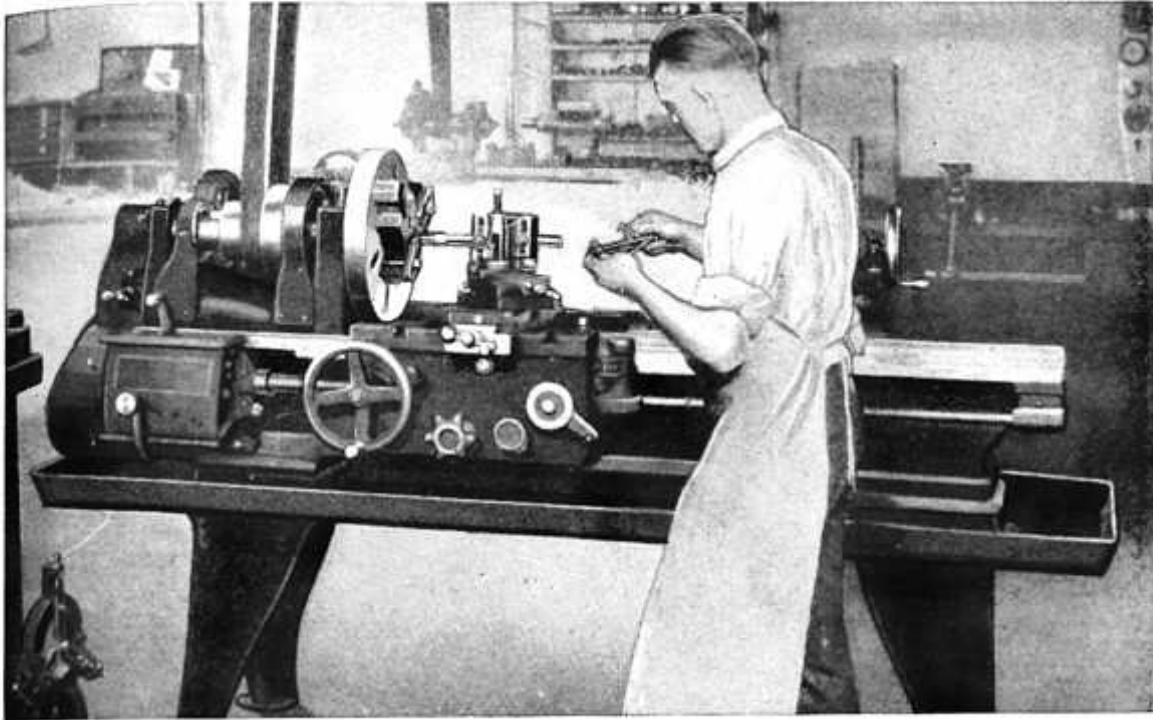

Fig. 531

Fig. 529.—A bronze ring being held in a Universal Chuck and a collapsible tap held in the tail spindle of the lathe. This tap is fed to the work and at the proper depth it collapses and is withdrawn from the ring without reversing the lathe spindle.

Fig. 531—A round piece of work being held in a 4-Jaw Universal Lathe Chuck while being machined.



MACHINING ON THE FACE PLATE

The large face plate of the lathe is designed so that various classes of work may be clamped to it while being machined.

The face plate is especially valuable in tool room work for the laying out and machining of holes in tools and jigs.

These holes must be very accurate, and should not vary more than .001 of an inch in the size of the hole and in the distance between holes.

The face plate is also used for holding jigs for the boring of special work on the lathe and for many other purposes.

MOUNTING A FACE PLATE

Before mounting a face plate on the spindle nose of the lathe, all dirt and chips should be removed from the threaded hole.

Clean the thread on the spindle nose and the shoulder of the spindle, because any dirt on either the tapped hole of the face plate or on the spindle nose will not allow the face plate to run true when it is screwed up to the shoulder.

A few drops of oil on the spindle nose will allow the face plate to screw on easily and be easily removed. If the face plate screws on tightly, unscrew the plate, remove the dirt and try again. The back of the face plate hub should screw tight against the shoulder of the spindle. Do not, however, run the face plate up to the shoulder suddenly as it strains the spindle and the threads and makes removal difficult.

The instructions above, referring to the mounting of the face plate, also apply to the mounting of a lathe chuck on the spindle nose.

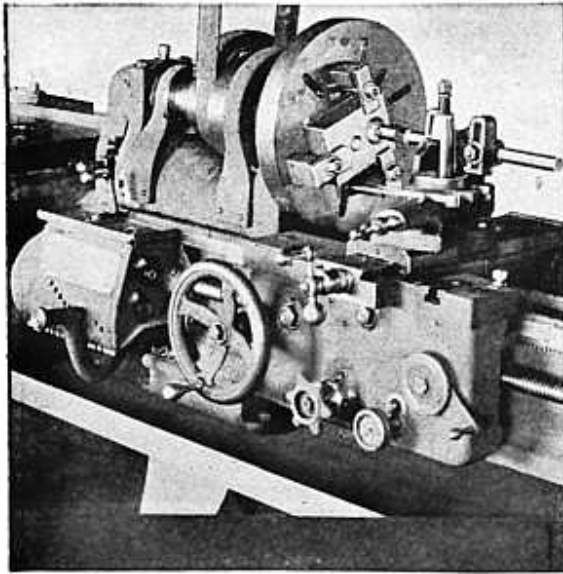

Fig. 532

Fig. 532.—A blanking die clamped to the face plate of the lathe while being machined.

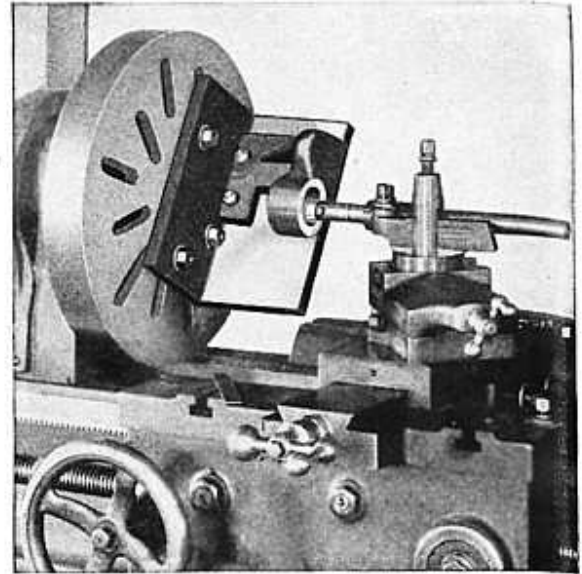

Fig. 533

Fig. 533.—Boring a spindle bracket on an angle iron that is clamped to the face plate of the lathe.

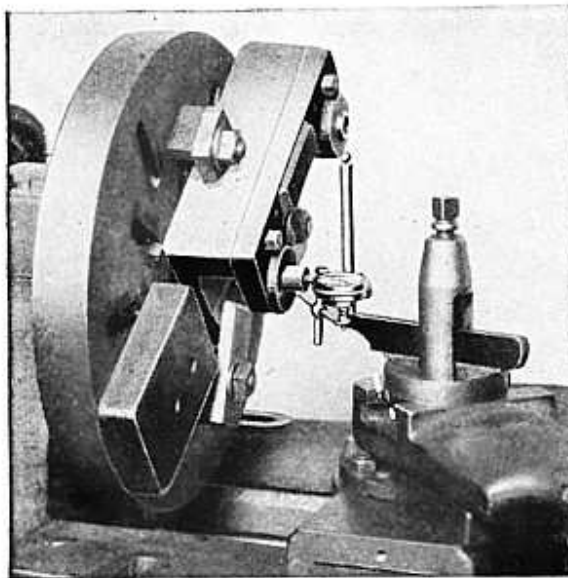

Fig. 534

Fig. 534.—A tool job being trued up by a tool makers' button and a dial test indicator.

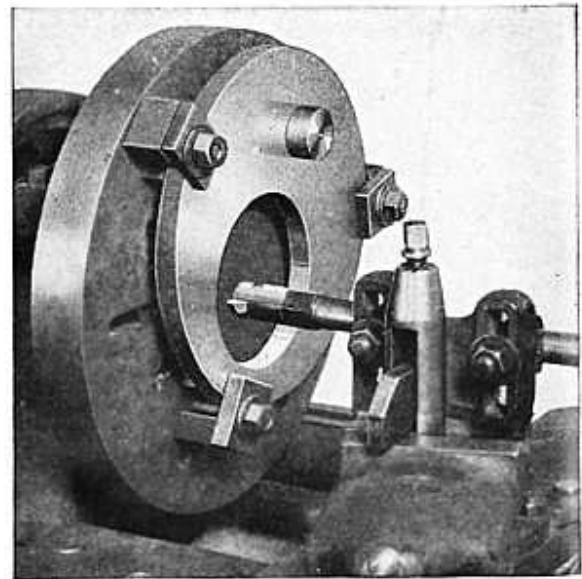

Fig. 535

Fig. 535.—Boring an accurate hole in a steel disc clamped to the face plate of a lathe.

In clamping work to a face plate the surface of the work having been machined, place a piece of paper between the work and the face plate, then clamp, and the danger of work slipping will be very much reduced.

CLEANING THE THREADED HOLE OF A CHUCK OR FACE PLATE

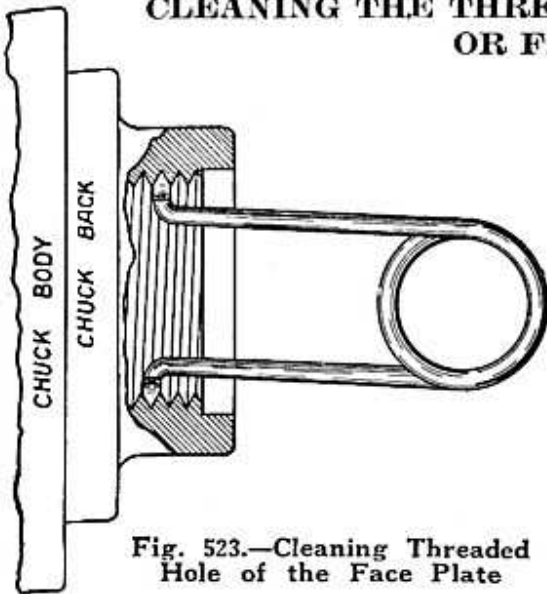

Fig. 523.—Cleaning Threaded Hole of the Face Plate

Fig. 523 shows a simple device made of ordinary brass wire for the cleaning of a threaded hole of a chuck or a face plate before screwing same on the spindle nose of the lathe.

The wire has more or less spring to it so that the device is adjustable and can be used for chucks and face plates of different sizes.

REMOVING A TIGHT FITTING FACE PLATE OR CHUCK FROM THE LATHE SPINDLE

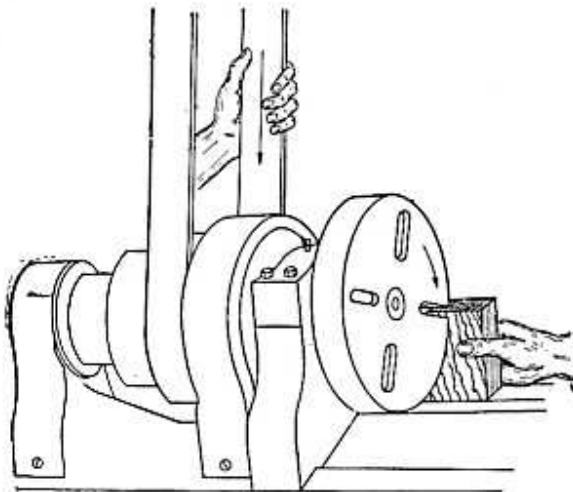

Fig. 524.—Removing Tight Fitting Face Plate from Lathe Spindle

Fig. 524 shows a practical method of removing a tight fitting chuck or face plate from the spindle of the lathe.

Connect the back gear drive; adjust the belt for the slowest speed, set the wood block on the back ways of the lathe; turn the spindle slowly backwards by pulling on the belt. When the slot in the face plate strikes the wood block it will loosen the plate.

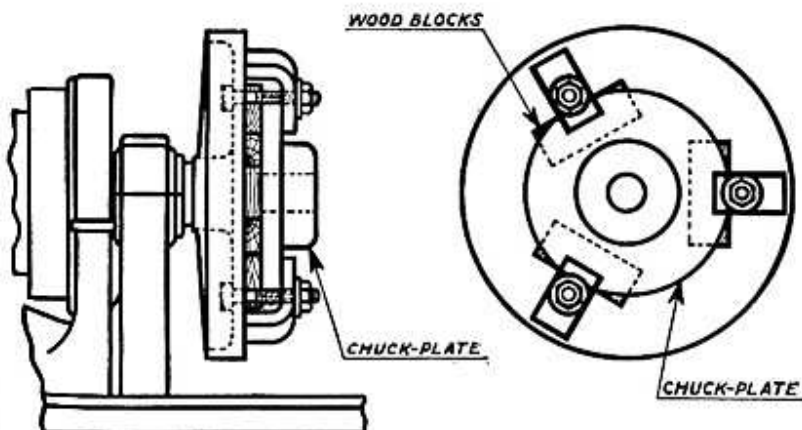

Fig. 525.—Machining a Chuck Plate

THREADING A CHUCK PLATE CLAMPED TO THE FACE PLATE

Fig. 525 shows a chuck plate casting clamped to the face plate to be bored and threaded to fit spindle nose of the lathe.

This is necessary when the new lathe is the only lathe in the

shop and it is necessary to fit a chuck to this lathe.

In threading a chuck plate in this manner, if you wish to test the thread to see if it is finished, unscrew the face plate without disturbing the chuck plate, and test the work on the spindle nose. If it does not fit and needs another chip, replace the face plate and take the chip.

TESTING INSTRUMENTS FOR CHUCK AND FACE PLATE WORK

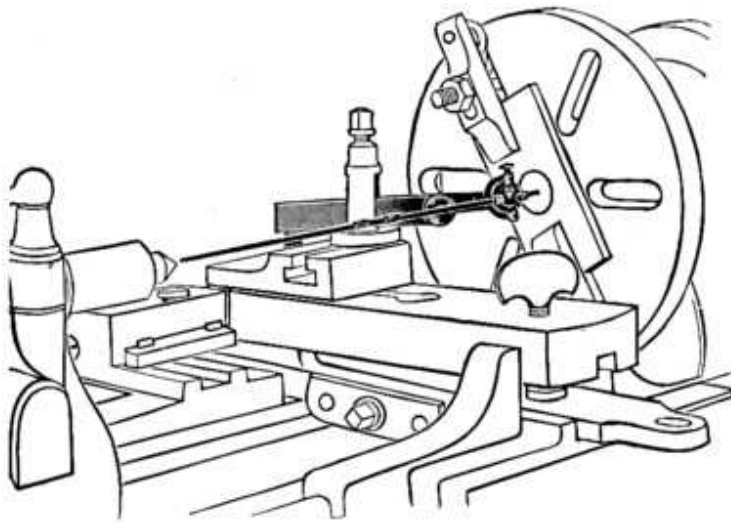

Fig. 517.—Application of Center Tester

Fig. 517 shows the application of a center tester truing a job that has been clamped to the face plate of the lathe. The position of the hole in the work has been laid out and the center has been indicated by a prick punch mark. One end of the center tester bar is placed in the prick punch mark and as the spindle is rotated the outer end of the test rod should run true.

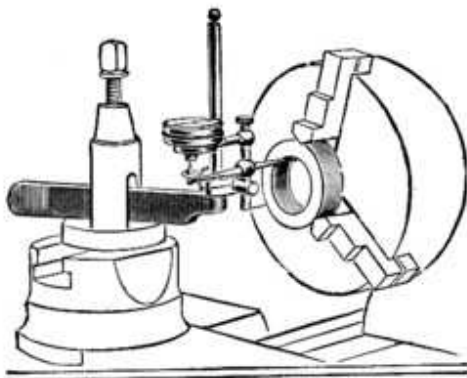

Fig. 518.—Application of a Dial Indicator in Testing Interior Surfaces

Fig. 518 shows the application of a Universal Test Dial Indicator. The indicator is held in the tool post of the lathe. The dial bottom has a small button which rests on the revolving work that is to be tested.

The face of the dial is graduated, reading in thousandths of an inch, and the measuring is done by a small revolving indicator hand. This measuring dial is very sensitive and practical. Its uses are many. For example: testing the alignment of lathe spindles, testing interior of a revolving cylinder, etc. etc.

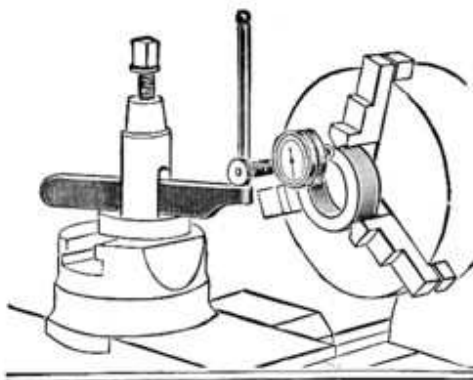

Fig. 519.—Application of a Dial Indicator on End Surfaces

APPLICATION OF THE TEST DIAL INDICATOR ON SURFACE WORK

Fig. 519 shows a Test Dial Indicator testing the face of a revolving piece of work that is held in the chuck. Another use for this dial tester is to place it in the tool post of the lathe and test the face plate while the face plate is revolving, and also testing it while the face plate is at rest by simply feeding across the surface of the plate.

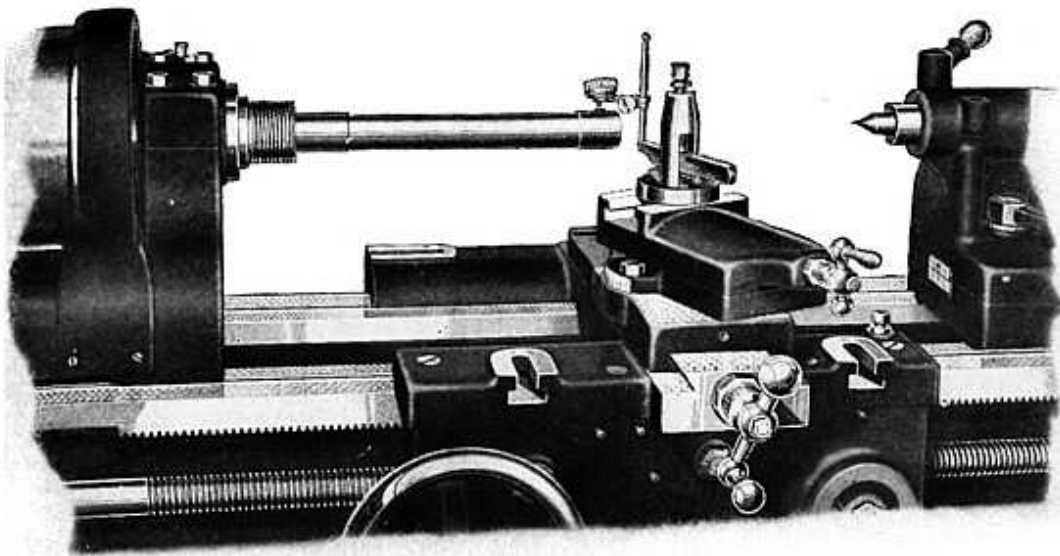

Fig. 520

TESTING HEAD STOCK SPINDLE WITH TEST BAR AND TEST INDICATOR

Fig. 520 shows the method of testing the head stock spindle of a lathe to see that the taper of the spindle runs true and that the axis of the spindle is parallel to the ways of the lathe.

The test bar is made of steel and ranges from 12" to 18" long, depending on the size of the lathe. It is machined between centers and ground on the taper shank and also on the two larger diameters as shown above. An Indicator placed on this bar as shown in the cut can detect an error of one ten thousandth of an inch.

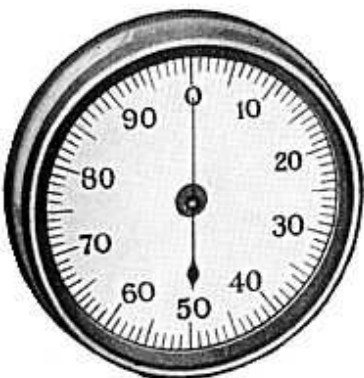

Fig. 521

DIAL OF TEST INDICATOR

The illustration shows the dial of the test indicator. The circumference of the dial is divided into one hundred equal spaces, each representing a movement of the contact point of one-thousandth of an inch.

In testing a lathe for accuracy even when the lathe is being assembled it is necessary that it be leveled carefully, and that the weight of the lathe is distributed equally on the four legs, and that each leg sets firmly on the floor.

FACTORY TEST CARD	
OF  THE	
SOUTH BEND LATHE	
ORDERED BY <i>Acme Supply Co.</i>	DATE <i>Sept 5-24.</i>
SHIPPED TO <i>Union Mfg. Co.</i>	DATE <i>Sept 13-24.</i>
CATALOG No. <i>69 E</i>	SERIAL No. <i>31268</i>
SIZE OF LATHE <i>16" X 8'</i>	TYPE OF LATHE <i>C. C. S.</i>
TEST RECORD	LIMIT OF ERROR
HEAD SPINDLE TAPER - Outer end of 12" test bar runs true <i>.0025</i>	.001"
HEAD SPINDLE TAPER - 12" test bar parallel with bed <i>.000</i>	.001"
TAIL SPINDLE - Parallel with lathe bed <i>.0025</i>	.001"
CENTERS - Alignment of <i>.0025</i>	.001"
FACEPLATE - Convex <i>.002</i>	.001"
FACEPLATE - Concave <i>.0025</i>	.001"
CHUCK - Jaws true on face <i>OK</i>	
LEAD SCREW - Final test <i>OK</i>	
SADDLE - Bearing on cross slide dovetail <i>OK</i>	
SADDLE - Bearing on bed <i>OK</i>	
COUNTERSHAFT - Clutch test <i>OK</i>	
ASSEMBLED BY <i>H. J. Greenert</i>	DATE <i>Sept 10-24.</i>
TESTED BY <i>R. S. Young</i>	DATE <i>Sept 12-24.</i>
SOUTH BEND LATHE WORKS	
SOUTH BEND, IND. U.S.A.	

Fig. 522

FACTORY TEST CARD OF FINISHED LATHE

The Factory Test Card illustrated above shows a record of some of the principal tests that are made on each screw cutting engine lathe.

Eleven final major tests, as indicated on the Factory Test Card above, are made just before the lathe leaves the factory. A complete record of these tests is kept on file in the office of the manufacturer for future reference.

ACCURACY TESTS OF LATHE INSURE PRECISION

Each lathe during the process of manufacturing and assembling undergoes sixty four important accuracy tests with precision instruments. For example: When boring headstock bearings, every alternate headstock is tested as it comes from the boring machine to see that it is bored accurately. Similar tests are made on the tailstock, carriage and saddle, etc.

KEEP THE LEAD SCREW CLEAN

All dirt and dust should be removed from the Lead Screw at least once a month. A good way to do this is to take a stiff brush, dip it in gasoline and brush the Lead Screw while it is slowly revolving.

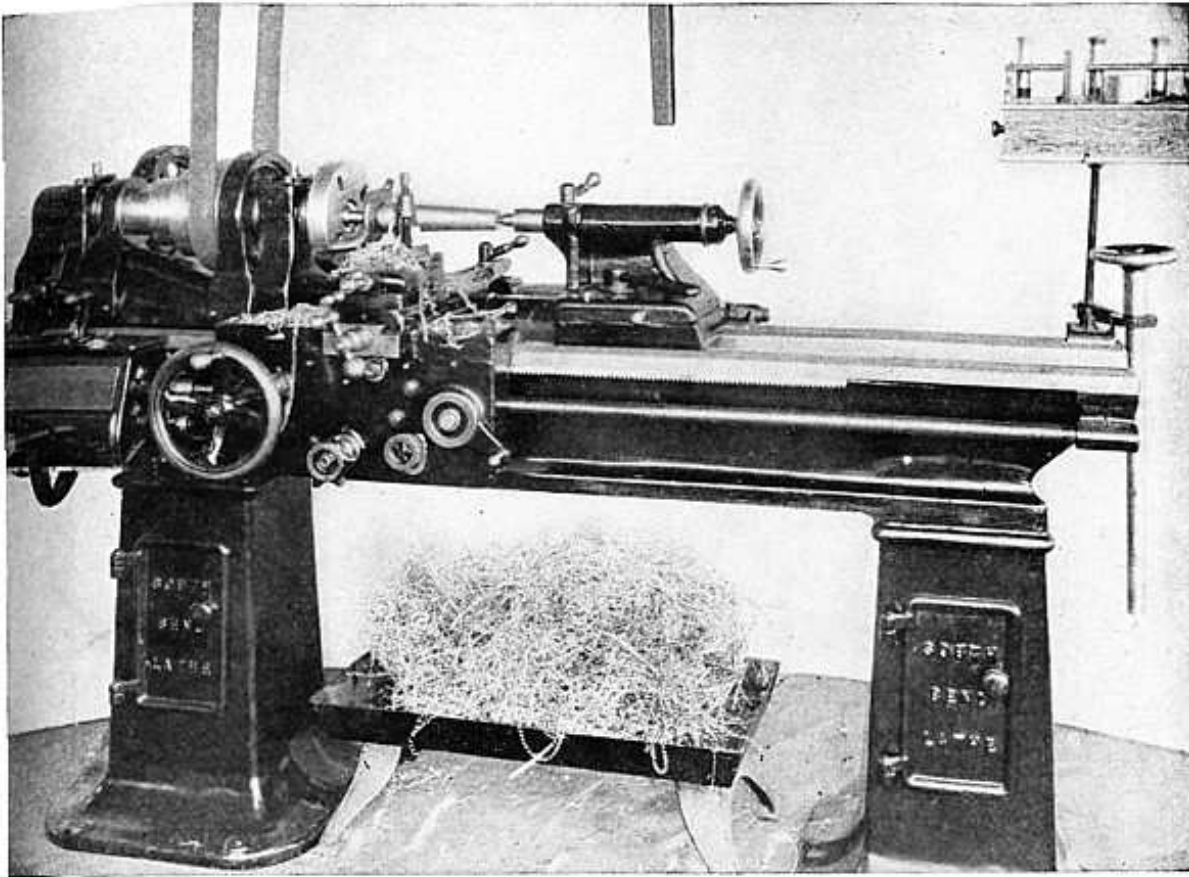

TAPER TURNING AND TAPER BORING

There are three methods of turning and boring tapers in the lathe: By setting over the tail stock; by using the compound rest; and by using the taper attachment of the lathe.

Turning taper by setting over the tail stock is the most common method used in the machine shop, when the lathe is not equipped with a taper attachment.

The compound rest covers a great variety of taper work, principally for turning and boring tapers for tool and jig work, also for die making, etc.

The taper attachment is used for production work, also where a number of pieces of the same kind are to be turned or bored to a definite taper, and for extreme taper work which cannot be machined by the tail stock set over method.

HEIGHT OF CUTTING EDGE OF THE TOOL FOR TAPER TURNING AND BORING

For the turning and boring of tapers, the cutting edge of the tool should be set exactly at the center of the work. That is, set the point of the cutting edge even with the point of the tail stock or head stock center of the lathe.

The position of the cutting edge of the tool applies to all methods of turning and boring tapers; such as the set over tail stock method; the compound rest and the taper attachment methods.

MORSE TAPERS

Fig. 536 shows the Morse Standard Tapers which are used as the taper in spindles by many manufacturers of lathes and drill presses in the United States. South Bend Lathes have both head and tail stock spindles fitted for Morse Standard Tapers.

MORSE TAPERS

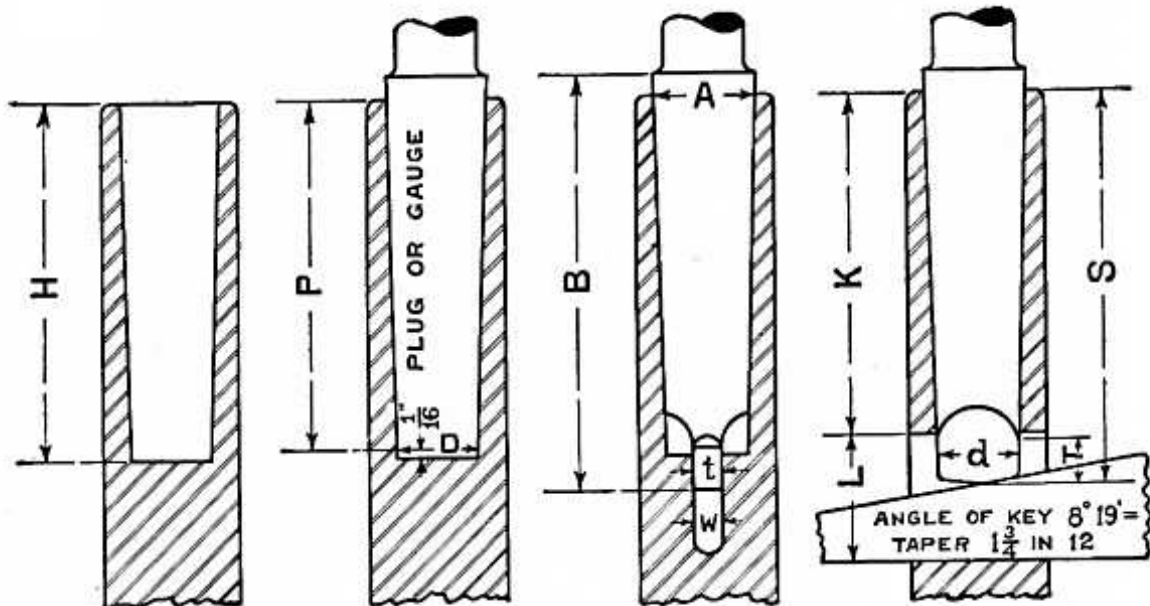

Fig. 536

DETAIL DIMENSIONS

NUMBER OF TAPER		0	1	2	3	4	5	6	7	
DIAM. OF PLUG AT SMALL END		D	.252	.369	.572	.778	1.020	1.475	2.116	2.750
DIAM. AT END OF SOCKET		A	.3561	.475	.700	.938	1.231	1.748	2.494	3.270
SHANK	WHOLE LENGTH OF SHANK	B	2 $\frac{11}{32}$	2 $\frac{9}{16}$	3 $\frac{1}{8}$	3 $\frac{7}{8}$	4 $\frac{7}{8}$	6 $\frac{1}{8}$	8 $\frac{9}{16}$	11 $\frac{5}{8}$
	SHANK DEPTH	S	2 $\frac{7}{32}$	2 $\frac{7}{16}$	2 $\frac{15}{16}$	3 $\frac{11}{16}$	4 $\frac{5}{8}$	5 $\frac{7}{8}$	8 $\frac{1}{4}$	11 $\frac{1}{4}$
DEPTH OF HOLE		H	2 $\frac{1}{32}$	2 $\frac{3}{16}$	2 $\frac{5}{8}$	3 $\frac{1}{4}$	4 $\frac{1}{8}$	5 $\frac{1}{4}$	7 $\frac{3}{8}$	10 $\frac{1}{8}$
STANDARD PLUG DEPTH		P	2	2 $\frac{1}{8}$	2 $\frac{9}{16}$	3 $\frac{3}{16}$	4 $\frac{1}{16}$	5 $\frac{3}{16}$	7 $\frac{1}{4}$	10
TONGUE	THICKNESS OF TONGUE	t	$\frac{5}{32}$	$\frac{13}{64}$	$\frac{1}{4}$	$\frac{5}{16}$	$\frac{15}{32}$	$\frac{5}{8}$	$\frac{3}{4}$	1 $\frac{1}{8}$
	LENGTH OF TONGUE	T	$\frac{1}{4}$	$\frac{3}{8}$	$\frac{7}{16}$	$\frac{9}{16}$	$\frac{5}{8}$	$\frac{3}{4}$	1 $\frac{1}{8}$	1 $\frac{3}{8}$
	DIAMETER OF TONGUE	d	.235	.343	$\frac{17}{32}$	$\frac{23}{32}$	$\frac{31}{32}$	1 $\frac{13}{32}$	2	2 $\frac{5}{8}$
KEYWAY	WIDTH OF KEYWAY	W	.160	.213	.260	.322	.478	.635	.760	1.135
	LENGTH OF KEYWAY	L	$\frac{9}{16}$	$\frac{3}{4}$	$\frac{7}{8}$	1 $\frac{3}{16}$	1 $\frac{1}{4}$	1 $\frac{1}{2}$	1 $\frac{3}{4}$	2 $\frac{5}{8}$
END OF SOCKET TO KEYWAY		K	1 $\frac{15}{16}$	2 $\frac{1}{16}$	2 $\frac{1}{2}$	3 $\frac{1}{16}$	3 $\frac{7}{8}$	4 $\frac{15}{16}$	7	9 $\frac{1}{2}$
TAPER PER FOOT			.625	.600	.602	.602	.623	.630	.626	.625
TAPER PER INCH			.05208	.05	.05016	.05016	.05191	.0525	.05216	.05208
NUMBER OF KEY			0	1	2	3	4	5	6	7

SOUTH BEND LATHE WORKS

For Brown and Sharpe Tapers, see page 79.

TURNING TAPERS BY SET OVER TAIL STOCK

In straight turning on the lathe, the tail stock top and base are clamped at zero, as shown in Fig. 537, and when the operator has occasion to set over the tail stock for turning taper, he should, when the job is finished, always return the tail stock to zero position for straight turning.

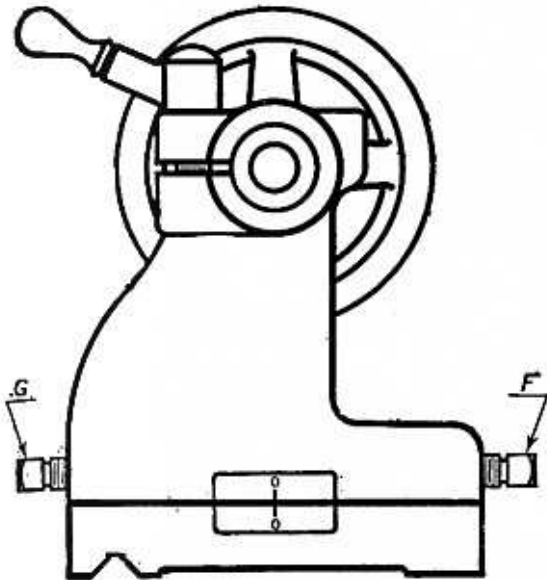

Fig. 537.—Tail Stock on Center for Straight Turning

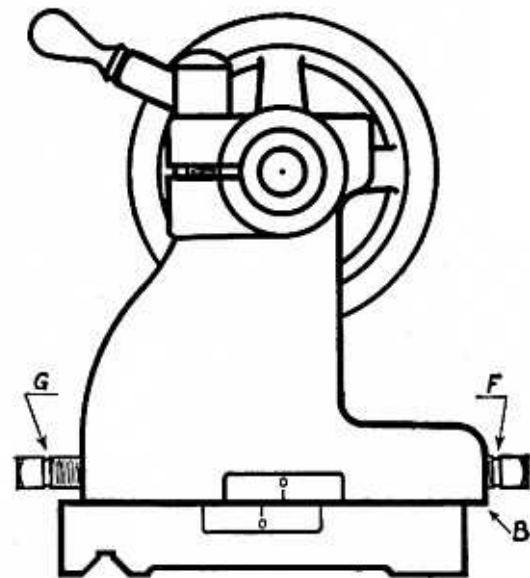

Fig. 538.—Tail Stock Off Center for Taper Turning

For taper turning by the set over tail stock method, the tail stock top is set off of its center position to get the desired angle of the taper. See Fig. 538.

SETTING OVER TAIL STOCK

To set over the tail stock for taper turning, loosen clamping nut of tail stock and back off set screw "G," the distance required, and screw in set screw "F" a like distance until it is tight, then clamp the tail stock to the lathe bed.

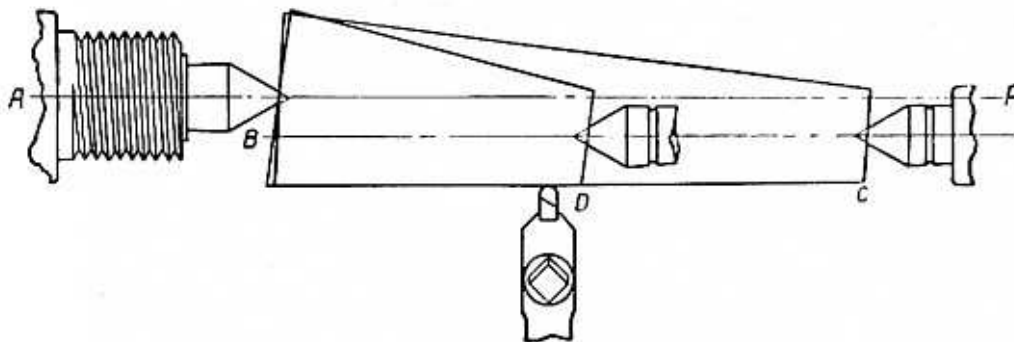

Fig. 539.—Turning Taper with Tail Stock Set Over

In turning taper by setting over the centers, the length of the tapered part of the work is important.

In Fig. 539 two pieces of work are shown, one just twice the length of the other, but set over distance of the tail center is exactly the same for both. The difference in taper between the two pieces of work is quite great, therefore the length of the tapered part of the work and the angle of taper must always be considered.

RULES FOR CALCULATING AMOUNT OF TAIL STOCK SET OVER FOR TURNING TAPERS

Case 1. Work to Be Tapered Its Entire Length.

Subtract the diameter of the small end of the taper from the diameter of the large end. Divide the difference by 2; this is the amount of set over required.

Case 2. Taper per Foot Is Specified on the Drawing.

Divide the total length of the stock in inches by twelve and multiply this quotient by one-half the amount of taper per foot specified. The result is the amount of set over.

Case 3. Taper per Foot Is Not Specified.

Divide the total length of the stock by the length of the portion to be tapered and multiply this quotient by one-half the difference in diameters; the result is the amount of the set over.

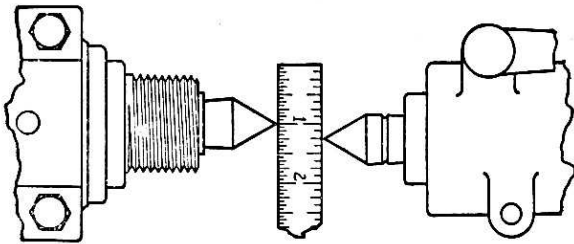

Fig. 540.—Measuring Set Over

MEASURING SET OVER

To measure the set over of tail stock, place a scale between the two centers (see Fig. 540) and this will give you the approximate measure based upon the length of the taper that you desire.

MORSE STANDARD TAPER GAUGES

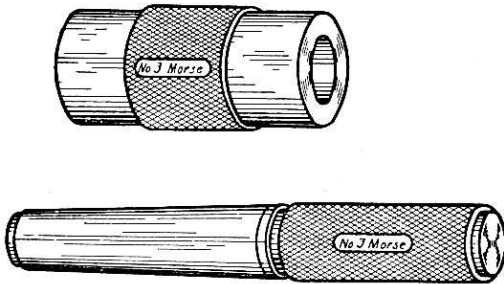
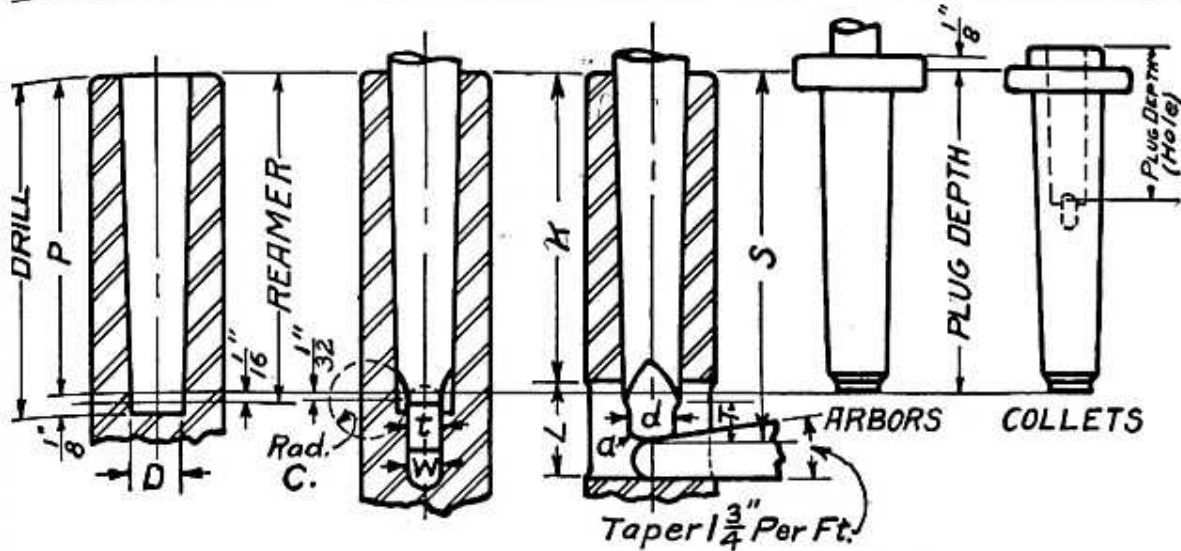

Fig. 541.—Morse Standard Taper Plug and Socket Gauge

Fig. 541 shows a Morse Standard Taper Plug and a Taper Socket Gauge. They not only give the proper taper, but also show the proper distance that the taper should enter the spindle.

TESTING A TAPER FIT

In testing the taper on a piece of work that is to fit a spindle and is nearly finished, make a chalk mark along the element or side of the taper piece. Place the work in the taper hole it is to fit and turn carefully by hand. Then remove the work and the chalk mark will show where the taper is bearing. If it is a perfect fit, it will indicate along the entire line of the chalk mark. If it is not, it will show where the adjustment is needed. Make the adjustment, take another light chip and test again. Be sure the taper is correct before turning to the finished diameter.



BROWN & SHARPE TAPERS

Taper .500" per ft. except No. 10 which is .5161" per ft.

No. of Taper	Diam. of Plug at Small End	Plug Depth P			Keyway from End of Spindle	Shank Depth	Length of Keyway	Width of Keyway	Length of Arbor Tongue	Diameter of Arbor Tongue	Thickness of Arbor Tongue	Radius of Tongue Circle	Radius of Tongue at a	Limit of Tongue to project thru Test Tool
		B. & S. Standard	Mill. Mach. Standard	Miscell.										
	D				K	S	L	W	T	d	t	c	a	
1	.200"	15/16			15/16	1 3/16	3/8	.135	3/16	.170	1/8	3/16	.030	.003
2	.250"	1 3/16			1 1/64	1 1/2	1/2	.166	1/4	.220	5/32	3/16	.030	.003
3	.312"	1 1/2		1 3/4	1 1/32	1 7/8	5/8	.197	5/16	.282	3/16	3/16	.040	.003
					1 23/32	2 1/8	3/8	.197	5/16	.282	3/16	3/16	.040	.003
4	.350"	1 11/16		1 1/4	1 13/64	1 21/32	11/16	.228	11/32	.320	7/32	5/16	.050	.003
					1 41/64	2 3/32	11/16	.228	11/32	.320	7/32	5/16	.050	.003
5	.450"	2 1/8		2	1 11/16	2 3/16	3/4	.260	3/8	.420	1/4	5/16	.060	.003
					2 15/16	2 7/16	3/4	.260	3/8	.420	1/4	5/16	.060	.003
6	.500"	2 3/8		2 1/2	2 1/16	2 9/16	3/4	.260	3/8	.420	1/4	5/16	.060	.003
					2 19/64	2 7/8	7/8	.291	7/16	.460	9/32	5/16	.060	.005
7	.600"	2 7/8		3	2 13/32	3 1/32	13/16	.322	13/32	.560	5/16	3/8	.070	.005
					2 25/32	3 13/32	13/16	.322	13/32	.560	5/16	3/8	.070	.005
8	.750"	3 9/16		4	2 29/32	3 17/32	15/16	.322	15/32	.560	5/16	3/8	.070	.005
					3 59/64	4 1/8	1	.353	1/2	.710	11/32	3/8	.080	.005
9	.900"	4 1/4		5	3 7/8	4 5/8	1 1/8	.385	9/16	.860	3/8	7/16	.100	.005
					4 1/8	4 7/8	1 1/8	.385	9/16	.860	3/8	7/16	.100	.005
10	1.0446	5 11/16		6 7/32	4 27/32	5 23/32	1 5/16	.447	21/32	1.010	7/16	7/16	.110	.005
					5 17/32	6 13/32	1 5/16	.447	21/32	1.010	7/16	7/16	.110	.005
11	1.250"	6 3/4		7 1/2	6 1/16	6 15/16	1 5/16	.447	21/32	1.010	7/16	7/16	.110	.005
					6 25/32	6 21/32	1 5/16	.447	21/32	1.210	7/16	1/2	.130	.005
12	1.500"	7 1/8		8 1/4	6 13/16	7 15/16	1 1/2	.510	3/4	1.460	1/2	1/2	.150	.005
					6 31/32	7 15/16	1 1/2	.510	3/4	1.460	1/2	1/2	.150	.005
13	1.750"	7 3/4		9	7 9/16	8 9/16	1 1/2	.510	3/4	1.710	1/2	3/8	.170	.010
14	2.00"	8 1/4	8 1/4	10	8 3/32	9 3/32	1 11/16	.572	27/32	1.960	9/16	3/4	.190	.010
15	2.25"	8 3/4		11	8 17/32	9 31/32	1 11/16	.572	27/32	2.210	9/16	7/8	.210	.010
16	2.50"	9 1/4		12	9	10 1/4	1 7/8	.635	13/16	2.450	3/8	1	.230	.010

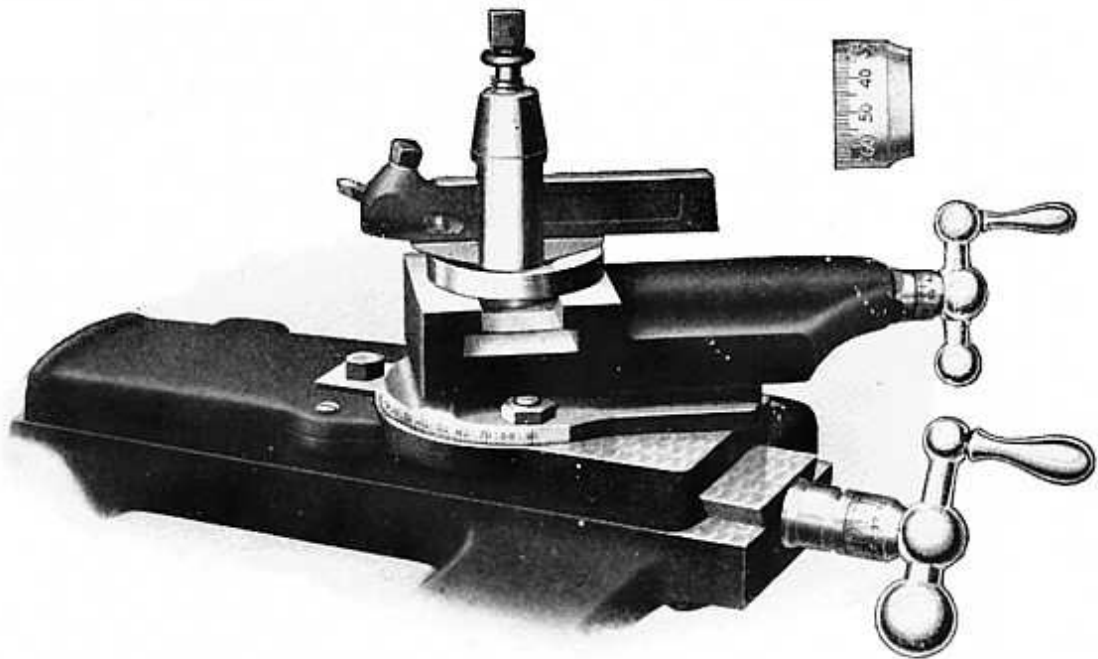

Fig. 543.—Graduated Compound Rest on Saddle of Lathe

THE GRADUATED COMPOUND REST OF A LATHE

The illustration shows the Compound Rest of a Screw Cutting Lathe mounted on the saddle. The base of the Compound Rest is graduated in 180 degrees so that it can be operated at any angle on the horizontal plane.

The Compound Rest Feed Screw and the Cross Feed Screw of the Saddle are both Acme Thread and each has a micrometer graduated collar reading in one-thousandths of an inch for regulating the depth of the cut.

All kinds of straight or taper work such as turning or boring short tapers and bevels, can be done because, in combination the Compound Rest Screw and Cross Feed Screw permit the cutting tool to be fed to the work at any angle for straight or taper machining.

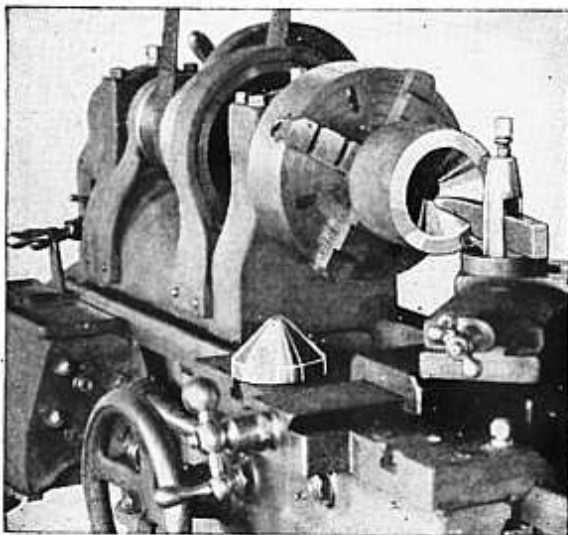

Fig. 544.—Machining a Conical Die in the Lathe, Compound Rest Set at 30 Degree Angle

DUPLICATE TAPER WORK

The compound rest is used very often for duplicating small tapers, as for example in Fig. 544, making a punch and die for forming a sheet metal cone. The die is machined in the chuck, and the desired taper is bored by using the compound rest. Then the punch is machined, and without changing the position of the compound rest, the taper of the punch is turned, which of course is identical with that of the taper of the die.

TRUING A LIVE LATHE CENTER

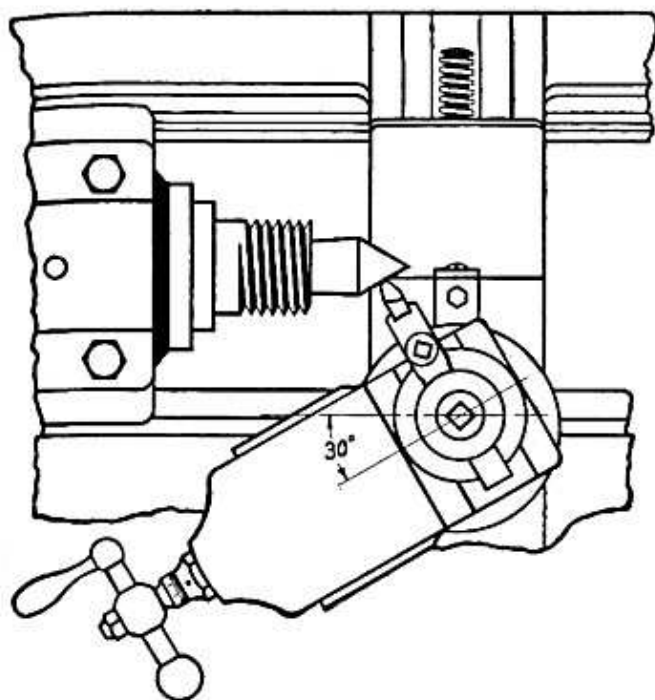

Fig. 545.—Truing a Lathe Center

To machine or true a lathe center, remove the face plate from the spindle. Before truing a lathe center examine the taper hole in the spindle and see that all dirt and chips are removed. Start the lathe, and with a piece of rag on the end of a stick, clean the taper hole thoroughly. Examine the shank of the lathe center and see that no chips are embedded in it and that all dirt is removed. Place the soft center in the spindle firmly, and set the compound rest at an angle of 30 degrees with the axis of the spindle. Place a round nose tool in the tool post. Set the cutting edge of the tool at the exact center point of the lathe center, and machine a chip to the taper

point, an angle of 60 degrees, and test with a center gauge.

TRUING A HARDENED LATHE CENTER

If the hard or tail spindle lathe center is to be trued up, anneal it and machine it in the head stock spindle, following the same operations described for truing a live center; then remove harden and temper and it is ready for use in the tail stock. If an electric tool post grinder is available, the hardened center may be trued up by grinding without annealing.

TESTING THE ANGLE OF A LATHE CENTER POINT WITH A CENTER GAUGE

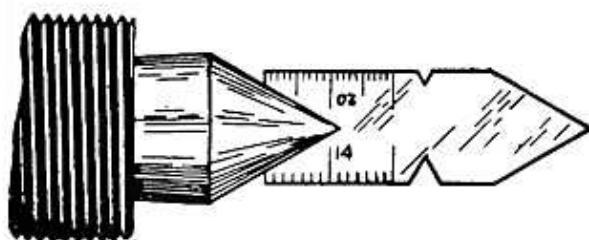

Fig. 546.—Testing Lathe Center Angle

Fig. 546 shows the method of testing the 60 degree angle of a lathe center point with a center gauge. All lathe centers, regardless of size, are finished to an angle of 60 degrees on the point that supports the work.

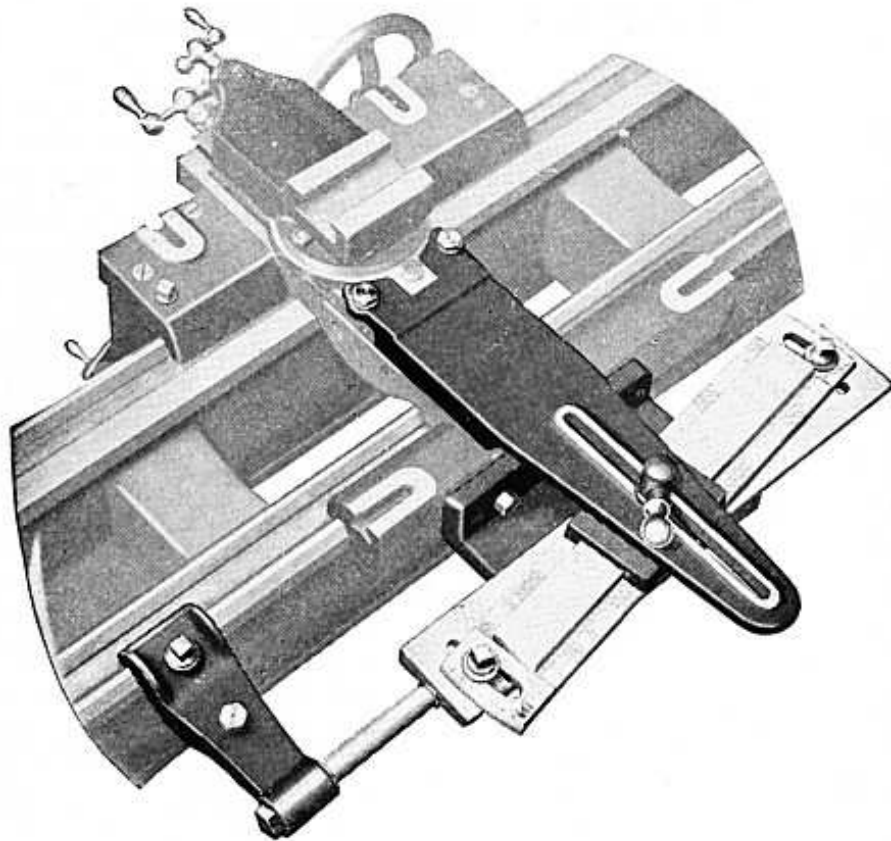

Fig. 547.—Graduated Taper Attachment for the Lathe

A GRADUATED TAPER ATTACHMENT FOR THE LATHE

Fig. 547 is a graduated taper attachment that is fitted to a lathe. The connecting slide is fastened to the tool cross slide. The angle base is secured to the back of the lathe saddle. The table is fastened to the angle base and attached on one end by a bracket clamped on the ways of the lathe. The swivel slide rail is pivoted on the table. This rail is graduated on either end—one end in degrees, and the other end in inches per foot of taper.

When the taper attachment is to be used, remove the screw that holds the cross feed control nut on the saddle and clamp the taper attachment to the ways by setting the square headed screw on the clamp, then the taper slide bar controls the feed of the slide rest and the taper attachment is ready for operation.

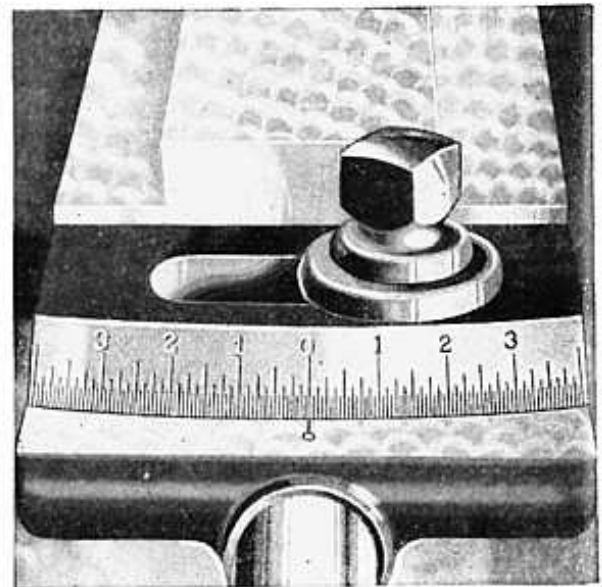

Fig. 548.—Close View of Graduated Taper

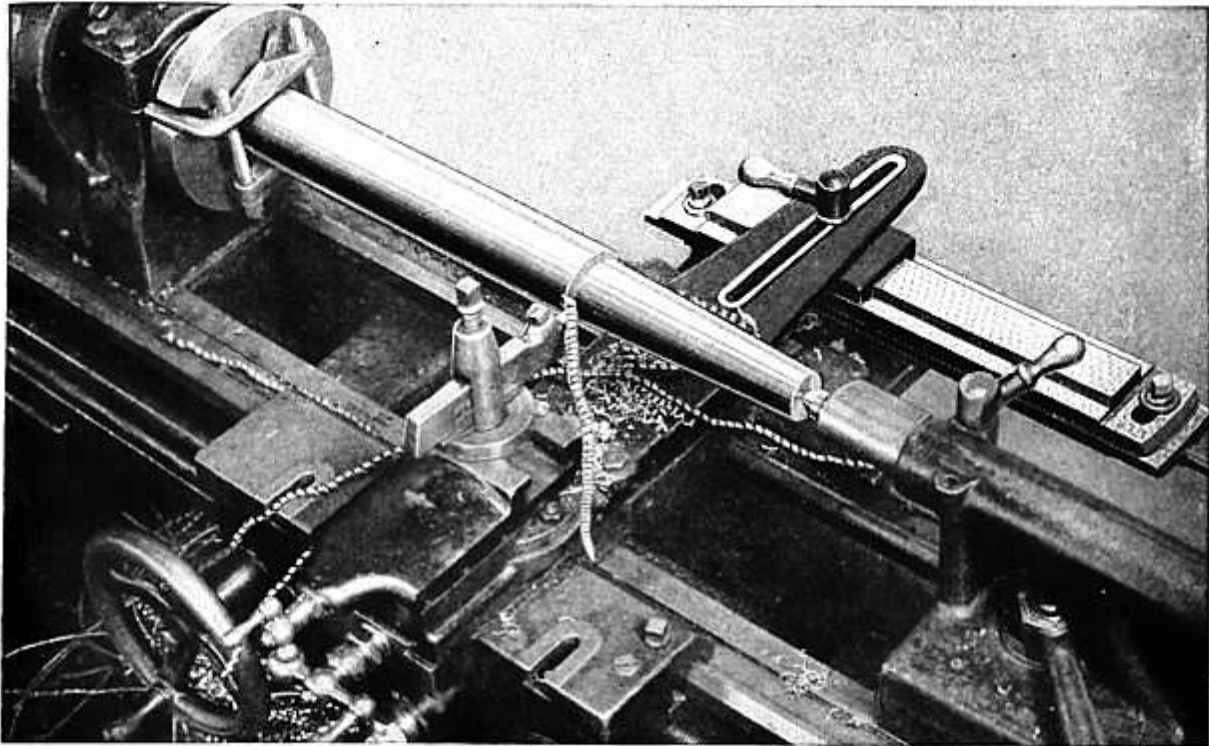

Fig. 549.—Turning with the Taper Attachment

Fig. 549 shows the application of taper attachment on a lathe, turning the taper shank of a spindle for a drill press. The taper is a Morse No. 5 and the job is being done between centers on the lathe.

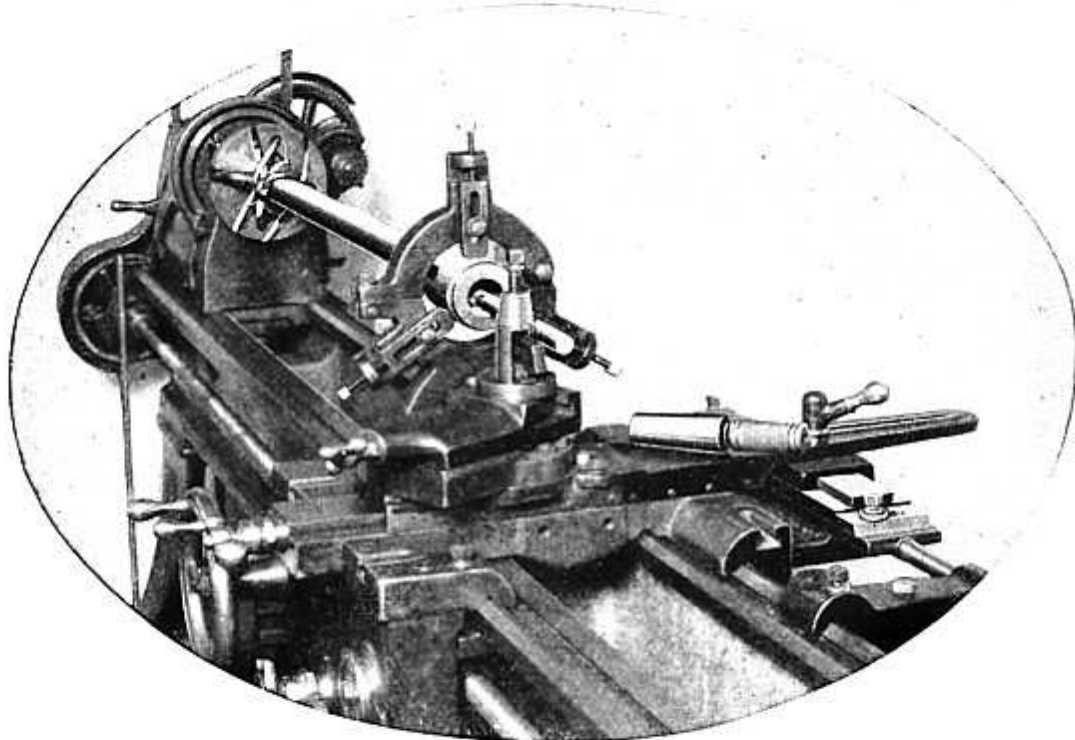

Fig. 550.—Boring with the Taper Attachment

Fig. 550 shows the application of the taper attachment boring a No. 4 Morse taper in a drill press spindle. One end of the spindle is held on the head center, the other end in the center rest.

After the spindle has been bored for the No. 4 Morse taper as illustrated above, it is good practice to stop the lathe and with a No. 4 Morse taper reamer, take a light chip turning the reamer by hand, using a tap wrench for turning. This operation will standardize size of the taper hole.

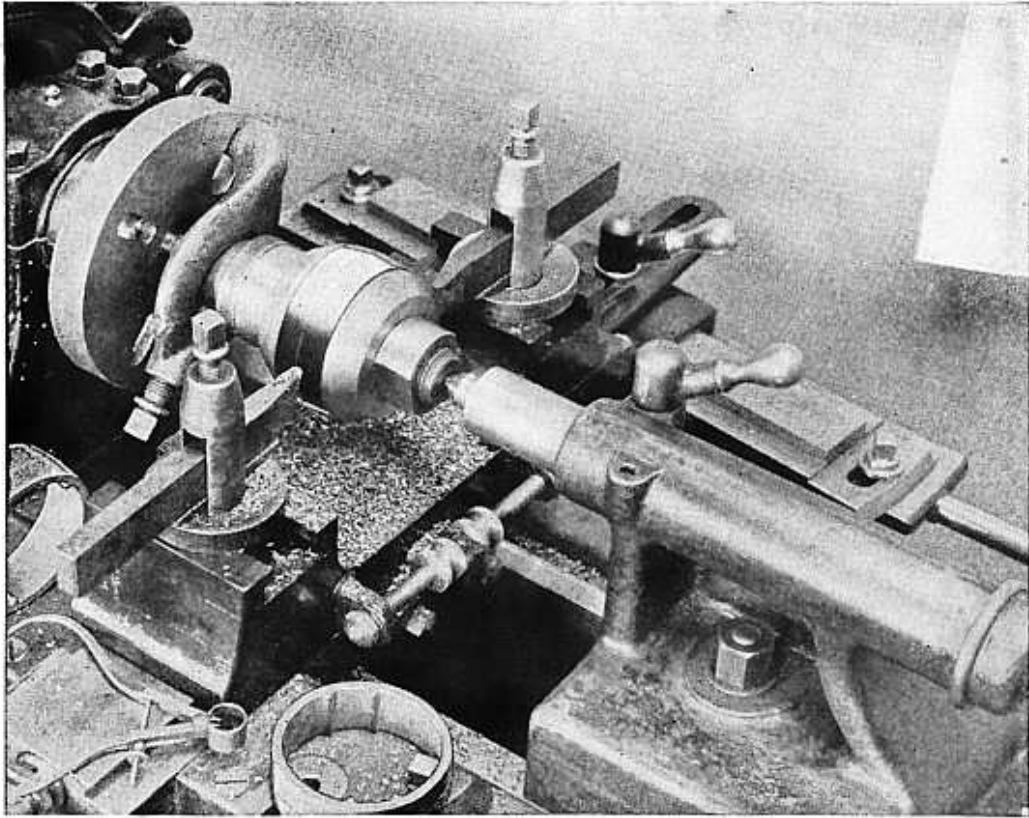

Fig. 551

Fig. 551.—Crowning a cast iron ring held on an arbor using two turning tools, the rear one, which is inverted, machining two different tapers in one operation with the use of the taper attachment. This job can also be done in the same manner with the set-over tail stock method. This job shows the application of two tool rests on the saddle of the lathe.

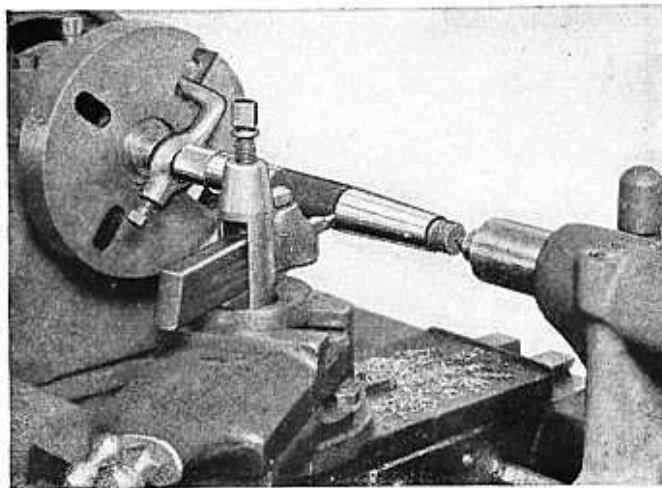

Fig. 552

Fig. 552.—Turning taper on a job between centers on the lathe by use of the set over tail stock method.

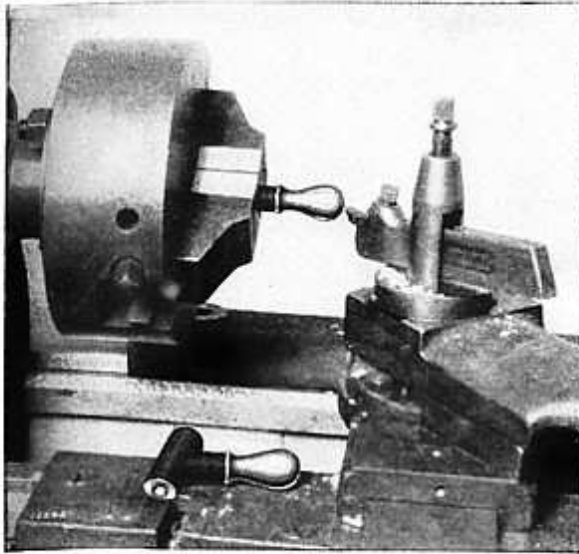

Fig. 638 shows a two jaw lathe chuck fitted to the spindle of the lathe for holding irregular work.

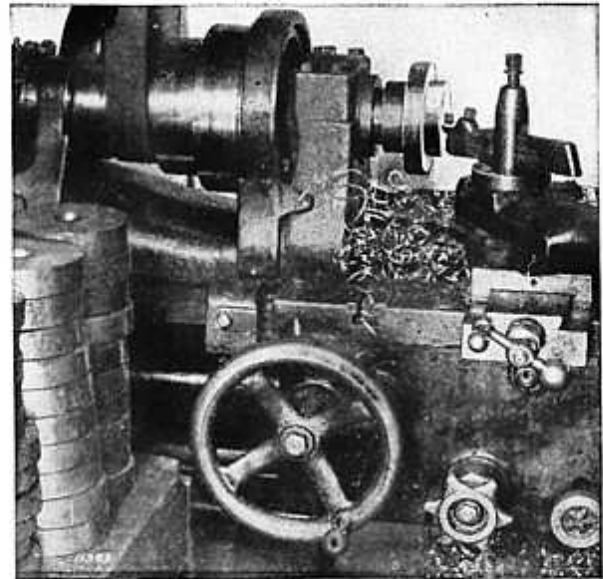

Fig. 639 shows a steel disc held to the face plate of the lathe by a draw-in chuck attachment while being machined.

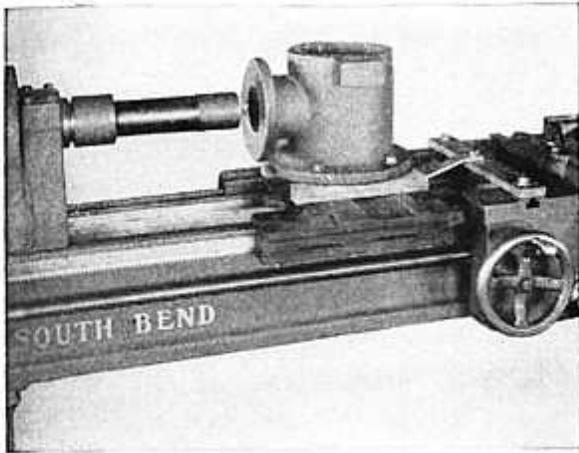

Fig. 640.—A cast iron T clamped to a special carriage on the bed of the lathe while being machined.

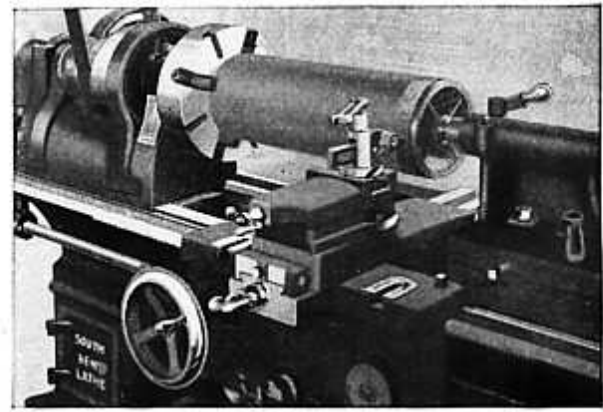

Fig. 641.—Machining a large wrought iron pipe in the lathe showing the application of the pipe centers.

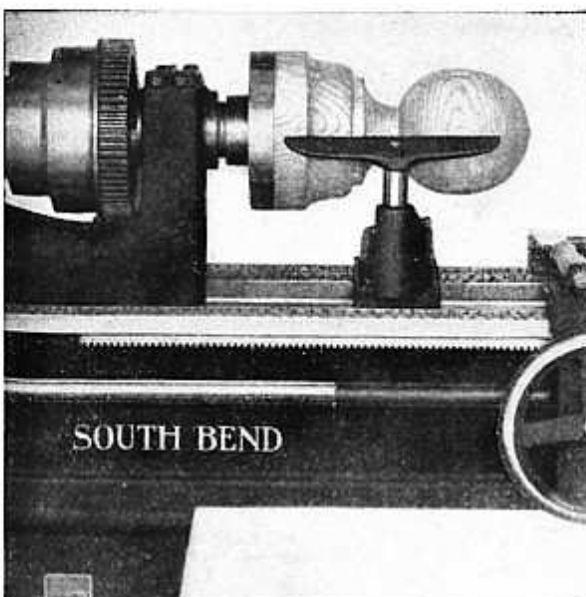

Fig. 642 shows a wood pattern being made on the lathe. The screw cutting lathe can be used for wood turning.

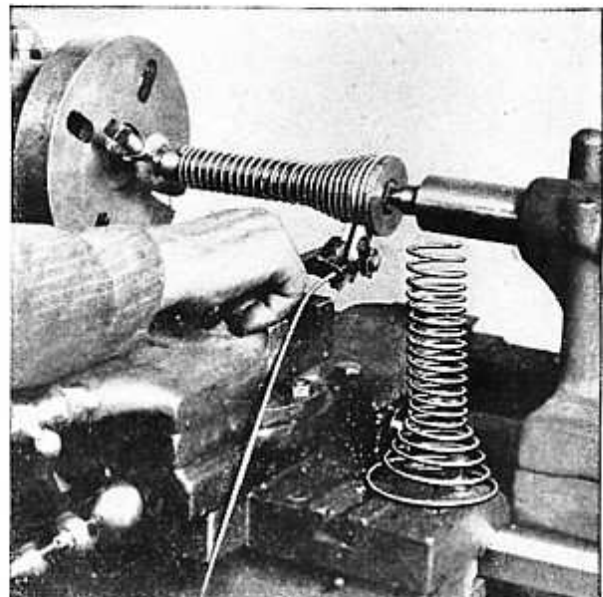

Fig. 643.—Winding a spiral spring on a special shaped arbor held between centers on the lathe.

TYPICAL SCREW THREADS CUT ON A MODERN BACK GEARED SCREW CUTTING LATHE



Thread Gauge



Tap

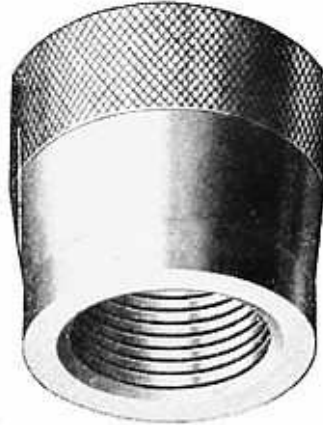

Internal U. S. Standard Thread



Tap



Thread Gauge

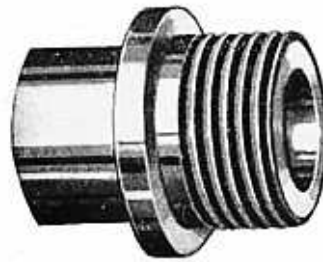

U. S. Standard Thread



Right Hand Acme Double Screw Thread

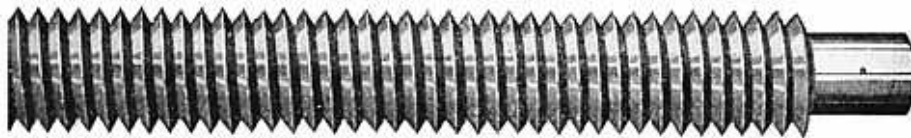

U. S. Standard Thread

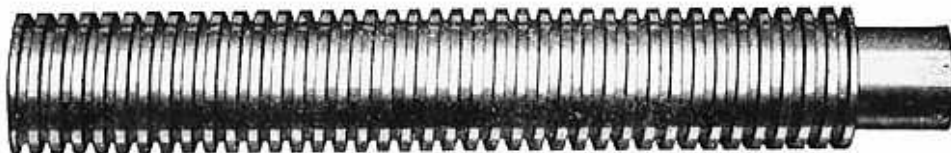

Left Hand Acme Screw Thread



Right Hand Double Screw Square Thread



CUTTING A SCREW THREAD ON THE LATHE

The American Engineers Standard Committee in May, 1924, sponsored by the S. A. E. and the A. S. M. E., received a report from the National Screw Thread Commission, as applying to the screw threads for bolts, machine screws, etc., defining the following terms:

TERMS RELATING TO SCREW THREADS

Screw Thread. A ridge of uniform section in the form of a helix on the external or internal surface of a cylinder or cone.

External Thread. An external thread is a thread on the outside of a member.

Internal Thread. An internal thread is a thread on the inside of a member.

Major Diameter. The largest diameter of a screw thread. The term "major diameter" replaces the term "outside diameter" as applied to the thread of a screw and also the term "full diameter" as applied to the thread of a nut.

Minor Diameter. The smallest diameter of a screw thread. The term "minor diameter" replaces the terms "core diameter" and "root diameter" as applied to the thread of a screw and also the term "inside diameter" as applied to the thread of a nut.

Pitch Diameter. On a straight screw thread the diameter of an imaginary cylinder the surface of which would pass through the threads at such a point as to make equal the width of the threads and the width of the spaces cut by the surface of the cylinder.

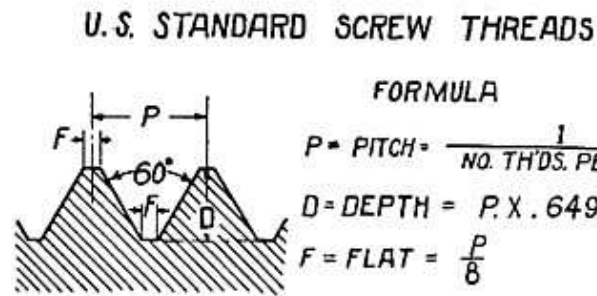
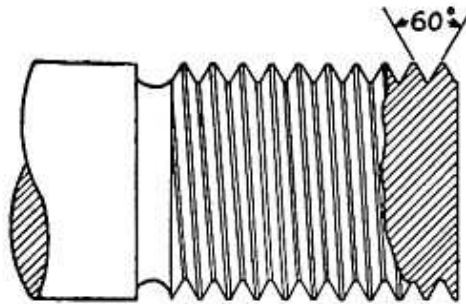

Fig. 553

U. S. STANDARD SCREW THREADS

The U. S. Standard Screw Thread has been approved by the American Engineering Standards Committee, and is now generally used by all shops in the United States.

STANDARD SCREW THREAD PITCHES

The tables below show U. S. Standard Thread, American Society of Mechanical Engineers Standard Thread and the Society of Automotive Engineers Standard Thread. The form of the S.A.E. and the A.S.M.E. threads is the same as that of the U.S.S. thread as shown in Fig. 553.

The tables show not only the standard number of threads per inch, for the diameter of the screw, but also the size of tap drill to use in order that the thread may tap to the proper size. Common fraction drill sizes are given when possible, but standard number and letter drills are necessary for the A.S.M.E. and the S.A.E. threads.

U. S. STANDARD THREAD

Tap Size	Th'ds Per In.	Drill Size	Tap Size	Th'ds Per In.	Drill Size
1/4	20	13/64	5/16	9	53/64
5/16	18	1/4	1	8	7/8
3/8	16	5/16	1 1/8	7	63/64
7/16	14	3/8	1 1/4	7	17/32
1/2	13	27/64	1 3/8	6	17/32
9/16	12	31/64	1 1/2	6	11/32
5/8	11	17/32	1 5/8	5 1/2	129/64
11/16	11	19/32	1 3/4	5	19/16
3/4	10	21/32	2	4 1/2	125/32
13/16	10	23/32	2 1/4	4 1/2	21/32
7/8	9	49/64	2 1/2	4	2 1/4

A.S.M.E. STANDARD THREAD

Tap Size	Th'ds Per In.	Drill Size	Tap Size	Th'ds Per In.	Drill Size
0	80	3/64	12	28	14
1	72	53			
2	64	50			
3	56	45			
4	48	43			
5	44	37			
6	40	33			
7	36	1/8			
8	36	29			
9	32	26			
10	30	22			

Screws over No. 12 run in fractional sizes starting with 1/4" and up as shown in the U. S. Standard Thread Table at left.

S.A.E. STANDARD THREAD

Tap Size	Threads Per In.	Drill Size	Tap Size	Threads Per In.	Drill Size	Tap Size	Threads Per In.	Drill Size
1/4	28	No. 3	1/2	20	29/64	3/4	16	11/16
5/16	24	17/64	9/16	18	1/2	7/8	14	53/64
3/8	24	21/64	5/8	18	37/64	7/8	14	13/16
7/16	20	25/64	11/16	16	5/8	1	14	15/16

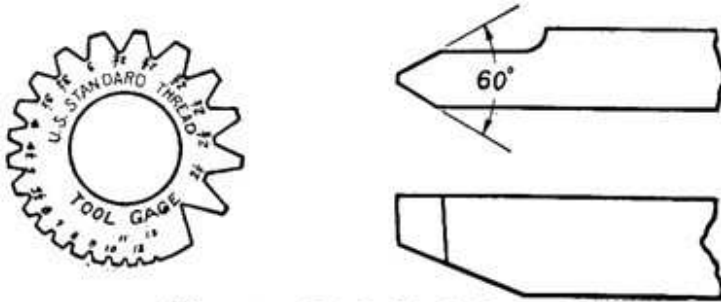

Fig. 554.—U. S. Tool Gauge

U. S. STANDARD TOOL GAUGE

Fig. 554 shows the U. S. Standard tool gauge for testing the cutting edge of a thread tool ground to cut the U. S. Standard screw thread.

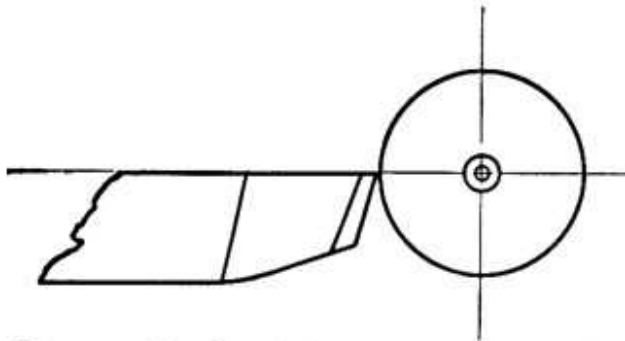

Fig. 555.—Height of Cutting Edge of Tool

HEIGHT OF THE CUTTING EDGE OF THE THREAD TOOL

Fig. 555 shows that the proper height for setting the cutting edge of the thread tool is exactly on the center, which is found by setting the cutting point of the thread tool even with the point of the lathe center.

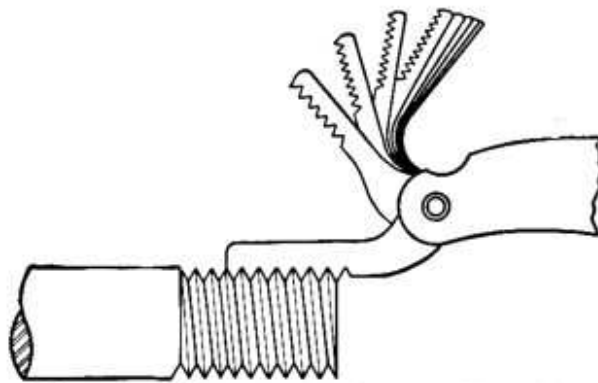

Fig. 556.—Measuring Screw Threads

MEASURING SCREW THREADS

Fig. 556 shows the application of a thread gauge in determining the number of threads to the inch on a bolt or screw. The thread gauge may also be used in determining the number of threads to the inch in a threaded nut.

MEASURING THE THREAD WITH A STEEL SCALE

Fig. 557 shows the method of finding the pitch of the thread when a thread gauge is not available. Place a scale on the screw so that the end of the scale is opposite the top point of any thread; count the number of spaces under the scale between the threads, for a distance of

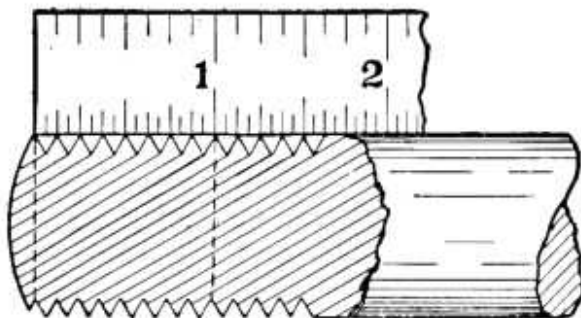

Fig. 557.—Measuring Screw Threads

one inch. For example: there are eight spaces underneath the scale in one inch, therefore, the screw is $\frac{1}{8}$ " pitch or eight threads per inch.

Another method is to place the scale as shown in Fig. 557 and count the top of the threads for a distance of one inch, omitting one thread.

SETTING THREAD TOOL FOR CUTTING EXTERNAL THREADS

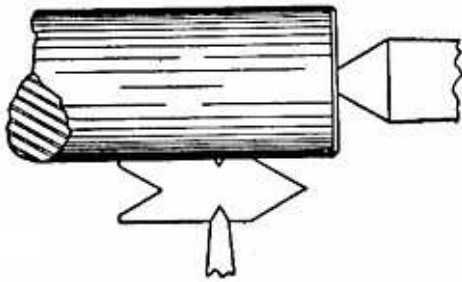

Fig. 558

Fig. 558 shows the method of setting the thread tool for cutting an external thread.

A thread gauge is placed on the point of the thread tool, and the tool is fed forward to the work. The tool should be adjusted so that the edge of the thread gauge is exactly parallel to the work.

SETTING THE TOOL FOR INTERNAL THREAD CUTTING

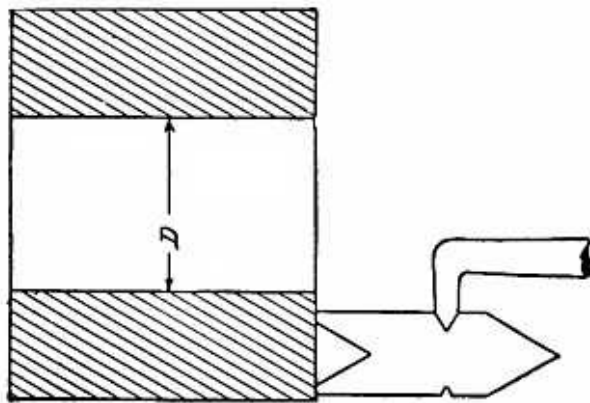

Fig. 559.—Setting Internal Threading Tool

Fig. 559 shows the method of setting a tool for cutting an internal thread on the work.

The tool is fastened in the tool post, a thread gauge is placed against the cutting edge of the tool and the carriage is brought forward so that the thread gauge is resting against the work. Both ends of the thread gauge should be parallel to the face of the work.

HEIGHT OF CUTTING EDGE OF AN INTERNAL THREAD CUTTING TOOL

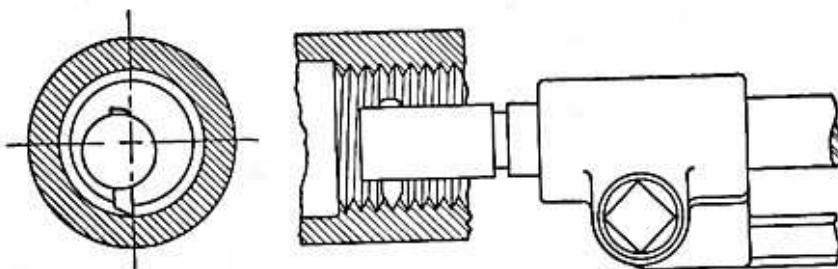

Fig. 560.—Setting Internal Threading Tool

Fig. 560 shows the method of setting a thread cutting tool for internal threads. The cutting edge of the tool is on the center line of the work.

The size of the threading tool for cutting an internal thread is important, because the tool head must be small enough so that it can be backed out of the thread and still leave enough clearance so that it can be drawn from the threaded hole without injuring the thread.

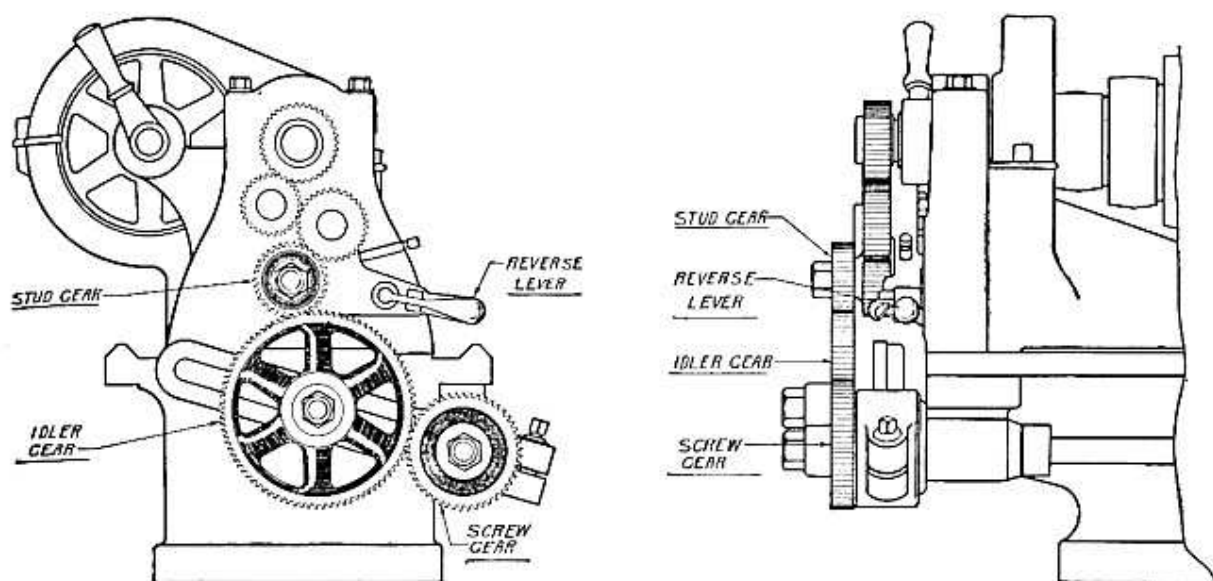

Fig. 561

LATHE SIMPLE GEARED FOR THREAD CUTTING

SOUTH BEND TRADE MARK ENGINE LATHES		
THREAD	9-11 STUD	SCREW
2	64	16
3	64	24
4	64	32
5	64	40
6	64	48
7	64	56
8	32	32
9	64	72
10	32	40
11	32	44
11½	32	46
12	32	48
13	32	52
14	32	56
16	32	64
18	32	72
20	32	80
22	16	44
24	16	48
26	16	52
28	16	56
30	16	60
32	16	64
36	16	72
40	16	80

SOUTH BEND LATHES WORKS
SOUTH BEND, IND., U. S. A.

Fig. 562.—Index Plate, 9"-11" Lathe

In Thread Cutting, the work is revolved by the lathe spindle, which in turn is geared to the lead screw. The ratio of the gearing between the spindle speed and the carriage feed determines the pitch of the thread.

A metal index plate is attached to the lathe, showing the necessary gears required to cut Standard Threads. There are three columns of figures on this Index Plate.

Thread Column indicates the number of threads per inch to be cut.

Spindle Column indicates the number of teeth on the stud gear.

Screw Column indicates the number of teeth on the gear that goes on the lead screw.

Example: To gear an 11" Standard Change Gear Lathe for cutting 16 threads per inch. By referring to the Index Plate, 16 threads calls for 32 teeth on the stud gear and a 64 tooth gear on the lead screw. Connect these two gears by a large idler gear which will mesh.

Compound Rest on an Angle for Cutting Threads

Some mechanics set the compound rest at an angle of 30° in cutting screw threads on a lathe when a quantity of screws are needed, the threading tool cutting only on one side of the thread. This method is satisfactory when the work is done by an experienced mechanic, but is not recommended for the apprentice as it requires skill in grinding and setting the thread cutting tool.

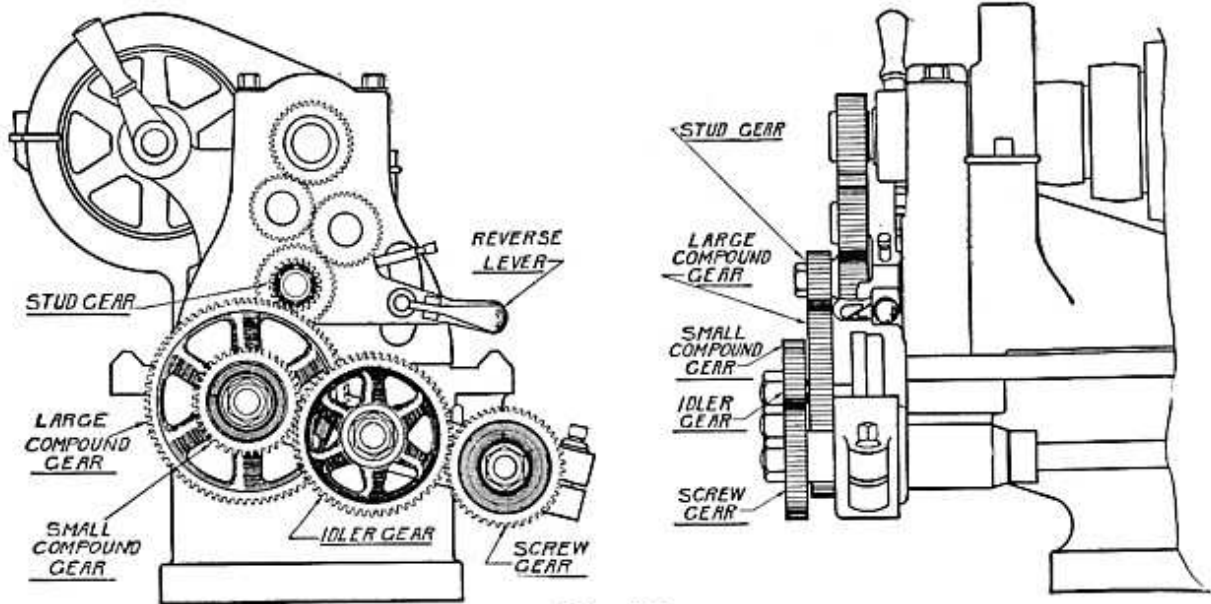

Fig. 563

SOUTH BEND TRADE MARK ENGINE LATHES		
13-15-16		
THREAD	SPINDLE	SCREW
2	72	24
3	48	24
4	48	32
5	48	40
6	48	48
7	48	56
8	48	64
9	48	72
10	48	80
11	24	44
11 1/2	24	46
12	24	48
13	24	52
14	24	56
16	24	64
18	24	72
20	24	80
22	24-1-2	44
24	24-1-2	48
26	24-1-2	52
28	24-1-2	56
30	24-1-2	60
32	24-1-2	64
36	24-1-2	72
40	24-1-2	80

SOUTH BEND LATHE WORKS
SOUTH BEND, IND., U. S. A.

Fig. 564.—Index Plate, 13", 15" and 16" Lathes

SOUTH BEND TRADE MARK ENGINE LATHES		
18-21-24		
THREAD	SPINDLE	SCREW
2	48	24
3	48	36
4	48	48
5	48	60
6	48	72
7	48	84
8	48	96
9	48	108
10	48	120
11	24	66
11 1-2	24	69
12	24	72
13	24	78
14	24	84
16	24	96
18	24	108
20	24	120
22	24-1-2	66
24	24-1-2	72
26	24-1-2	78
28	24-1-2	84
30	24-1-2	90
32	24-1-2	96
36	24-1-2	108
40	24-1-2	120

MADE ONLY BY
SOUTH BEND LATHE WORKS
SOUTH BEND, IND., U. S. A.

Fig. 565.—Index Plate, 18", 21" and 24" Lathes

COMPOUND GEARING FOR THREAD CUTTING

Fig. 564 shows Index Plate for the 13", 15" and 16" Standard Change Gear Lathes, geared with compound gears for cutting standard threads.

Compound gears are necessary when cutting fine threads on a lathe fitted with a lead screw having very coarse threads. To cut these fine threads we arrange the gearing in a train of at least four gears, two of which are compound gears.

Fig. 563 shows a 16" Standard Change Gear Lathe fitted with compound gear to cut 32 threads per inch. See Index Plate, Fig. 564.

For cutting 32 threads per inch on a 16" lathe, the stud gear has 24 teeth. The screw gear has 64 teeth. The compound gears are composed of two gears, one having twice the number of teeth as the other one. The smaller compound gear is connected with the screw gear by an idler, and the larger compound gear is connected direct to the stud gear.

Fig. 565 shows an Index Plate for the 18", 21" and 24" Standard Change Gear Lathes. These lathes have a 4 pitch lead screw. Therefore, the gears for cutting the threads vary somewhat from the gears on the 15" and 16" lathes, which have 6 pitch lead screws.

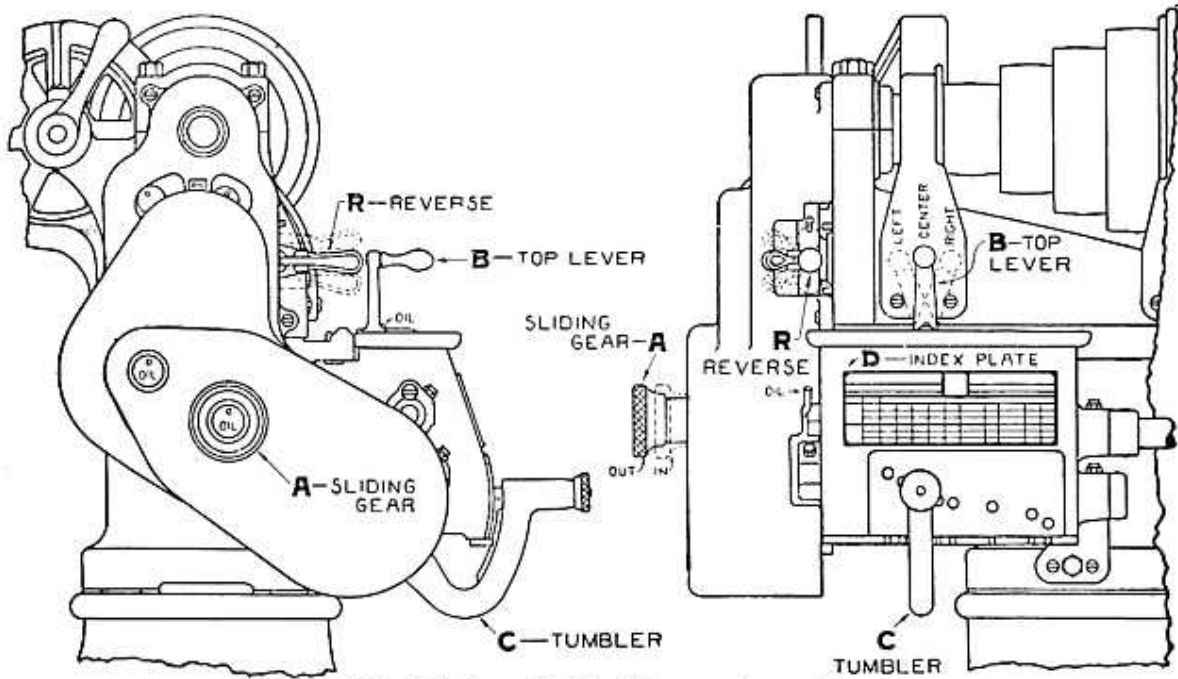

Fig. 566.—Flather Quick Change Gear Box

SOUTH BEND LATHE WORKS		SOUTH BEND, INDIANA, U. S. A.									
PATENT NO 810634.		QUICK CHANGE GEAR									
LONGITUDINAL FEEDS 2 3/4		TIMES THREADS PER INCH									
SLIDING GEAR	TOP LEVER	THREADS PER INCH									
IN	LEFT	2	2 1/4	2 1/2	2 3/4	2 7/8		3		3 1/4	3 1/2
	CENTER	4	4 1/2	5	5 1/2	5 3/4		6		6 1/2	7
	RIGHT	8	9	10	11	11 1/2		12		13	14
OUT	LEFT	16	18	20	22	23		24		26	28
	CENTER	32	36	40	44	46		48		52	56
	RIGHT	64	72	80	88	92		96		104	112

Fig. 567. Index Plate for South Bend Quick Change Gear Lathes for Feeds and Threads

INSTRUCTIONS FOR OPERATING THE GEAR BOX

1. Locate on Index Plate the number of threads per inch you desire to cut.
2. In the first column at the left, see if sliding gear "A" should be in or out and adjust sliding gear to the position indicated. Caution: Sliding gear must not be adjusted while lathe is running.
3. In second column from the left, note the position of top lever "B." Start lathe and shift lever to position indicated.
4. With lathe running, adjust the Tumbler "C" into the hole directly underneath the column in which you found the number of threads you wish to cut.
5. Stop lathe and set reverse bracket into down position. (This will feed carriage towards the headstock.)
6. The gear box is now properly adjusted to cut the desired thread.

Example: To cut 13 threads per inch, locate the figure 13 on the Index Plate. Place sliding gear "A" position in. Top lever "B" position right and Tumbler "C" in the hole directly under the column in which is found the Figure 13, which is the second last column.

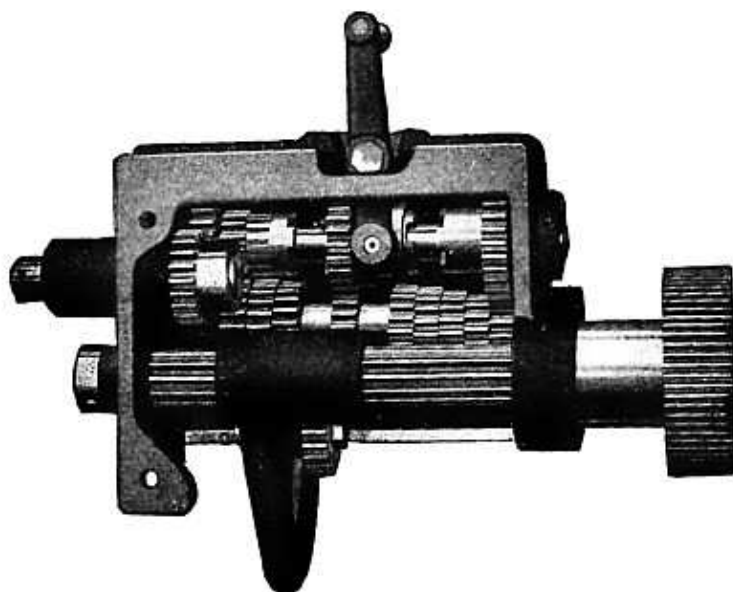

Fig. 568.—Interior View of Gear Box

QUICK CHANGE GEAR MECHANISM FOR LATHES

The Quick Change Gear mechanism on South Bend Lathes is the famous Flather Patent. The cone of eight steel gears is mounted upon a shaft, any gear can be instantly engaged by simply moving the lever in front of the box. On another shaft located above the cone of gears is a double clutch gear, controlled by the small lever on top of the box. The moving of this lever to three different positions increases the number of changes obtained by the lower lever to twenty-four, which number is doubled by moving the sliding gear at the end of the lathe making forty-eight in all.

OPERATING GEAR BOX FOR TURNING FEEDS

See drawing on Page 93 which shows gear box set for medium turning feed. This calls for Sliding Gear "A" set out position. Start the lathe and set Top Lever "B" right position. Lathe running, set Tumbler "C" in hole under 96 threads. For finer feed move Tumbler "C" to holes at right. For coarser feed, move Tumbler "C" to holes at the left.

ADJUSTMENT OF SLIDING GEAR "A"

Do not attempt to adjust sliding gear "A" position in or out while lathe is running. The simple way to adjust the sliding gear "A" is: stop the lathe, put the reverse handle "R" in neutral and adjust Sliding Gear in or out easily and quickly. Sliding Gear "A" will not function unless it is set to the extreme of either in or out position—any intermediate position will lock gears.

PREPARING FOR THE FIRST CHIP (THREAD CUTTING)

In cutting screw threads on the lathe, the carriage is driven by clamping half nuts on the lead screw.

The automatic cross feed, or the automatic longitudinal feed of the carriage must not be used while thread cutting. When setting a lathe for thread cutting, place the automatic feed lever knob in position **neutral** and fasten it. This will be necessary because the automatic safety lock will not allow the split nuts to be clamped on the lead screw until the automatic feed lever is in a neutral position.

See that the lathe dog is fastened tightly on the work to be threaded. Also see that the tail of the dog does not bottom on the face plate slot, and that there is oil on the tail center where it enters the work.

Be sure that the thread tool is properly ground and set and fastened firmly in the tool post.

Oil the lead screw and the half nuts.

Do not remove the dog from work until the thread has been finished and tested.

If for any reason you remove the work from the centers for testing the thread, mark the slot on the face plate if there are more than one in which the tail of the dog enters, and when replacing the work on centers, always place the tail of the dog back in the same slot.

The spindle should not be revolved or disturbed while the work is off the lathe centers.

EVEN GEARED LATHES

A lathe is even geared when the revolutions of the spindle and the revolutions of the reverse spindle stud are the same.

In cutting a screw thread if the lathe is even geared and if the number of threads per inch to be cut is exactly divisible by the number of threads per inch of the lead screw, it is not necessary to reverse the direction of the lathe spindle in order to automatically reverse the carriage to return the tool to the starting point. For example: if the lead screw is 8-thread and the screw that you wish to cut is divisible by eight, such as 8, 16, 24, 32, 40, etc., the lathe spindle may run in one direction all the time. When the tool has traveled to the end of the cut draw it out, open the split nut, and return the carriage to the starting position by hand. Throw in the split nut again, take another chip, and repeat this operation until the thread is finished.

The two practical methods of bringing the carriage back to the starting point after taking a threading cut are:

Reversing the direction of spindle rotation causing the carriage to run back automatically;

Opening the split nut and running the carriage back by hand, using the thread dial to engage the split nut.

The first method is used in the shop where there are not many threads to be cut.

The second method is generally followed in production work.

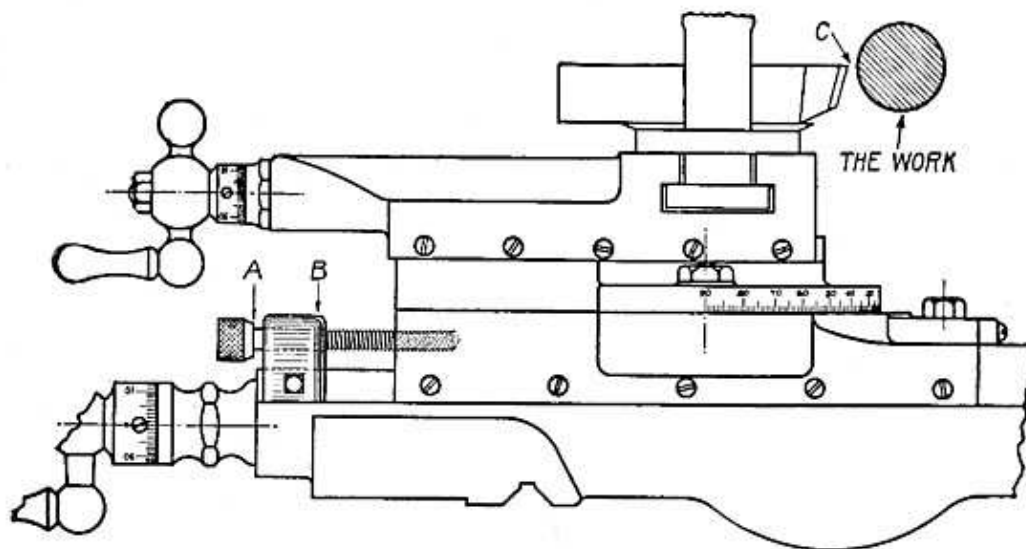

Fig. 569

THE THREAD CUTTING STOP

Fig. 569 shows the application of the adjustable stop for regulating the depth of each chip in thread cutting.

Bring the point of the tool up to the work, then turn the screw "A" until the shoulder is tight against the stop "B," which is clamped to the saddle. When ready to take the first chip, run the tool rest back by the cross feed screw, then turn screw "A" one quarter of a turn to the left. This will allow the point of the tool to take about $\frac{1}{8}$ of an inch on its first chip. Before taking each cut, turn the adjusting screw $\frac{1}{4}$ of a turn to the left.

If the work to be threaded is mild steel or wrought iron, plenty of oil should be used on the point of the tool and on the work.

To take the first chip, move the point of the tool about one-eighth inch away from the surface of the bolt. Move the carriage so as to bring the point of the tool a little to the right of the end of the work, clamp the half nuts firmly on the lead screw and start the lathe. Feed the tool to the work as far as the thread cutting stop will allow and take the first chip. When the tool reaches the end of the cut withdraw it by turning the cross feed screw to the left at least one complete turn so that the tool will clear the thread on the reverse travel of the carriage. Reverse the shipper-rod: this reverses the direction of the feed of the carriage which travels back automatically. When the point of the tool reaches the starting point, stop the lathe and measure the thread to see if you have the correct pitch.

Adjust thread cutting stop by unscrewing $\frac{1}{4}$ turn and take the second chip following the same operation as before, and continue until the thread is finished.

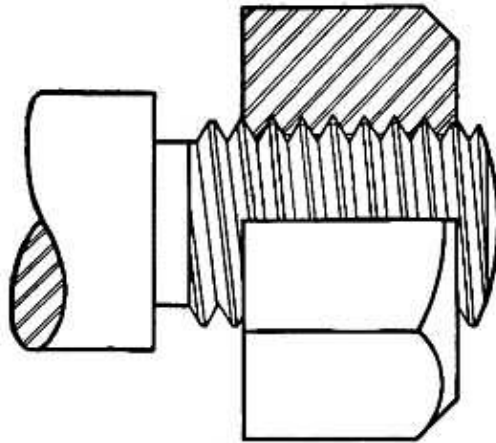

Fig. 570

FITTING AND TESTING SCREW THREADS

When cutting a screw thread and you think it is about finished and ready for testing, remove the work from the lathe centers, leaving the dog attached and test the thread in the threaded hole it is intended to fit, or to some nut or gauge. If the thread does not fit properly and needs another chip or two, place the work back in the centers and take the required chips and test again. Repeat this operation until the thread is finished.

For cutting an internal thread the same general instructions will apply as in cutting an external thread, with the exception that the adjustable stop for thread cutting should be set with the head of the adjusting screw on the inside of the stop.

In cutting screw threads where an accurate job is required; (for example, if you are making a tap) use plenty of lard oil on the tool and the work and be sure that the last or finish cuts are very light, so that the tool will take a fine smooth chip, and leave the surface of the thread smooth and polished.

GRINDING THE THREADING TOOL AFTER THE THREAD HAS BEEN STARTED

If it is necessary to remove the tool for grinding, before thread is finished, take the tool out and grind it, adjust the thread tool as before and fasten it, setting it opposite the thread groove. Turn the spindle forward by hand by pulling on the belt, and again test to see if the point of the tool is exactly opposite the thread in the work. If it is not opposite, disconnect the reverse gear, disconnecting the lead screw, and turn the spindle forward by hand until the tool fits exactly in the thread groove. Then connect the reverse gear as before and you may proceed with the cutting.

In turning the spindle by hand to reset the thread tool, always turn it forward. If you turn it backward, there will be a back lash and it will not show the true position of the tool.

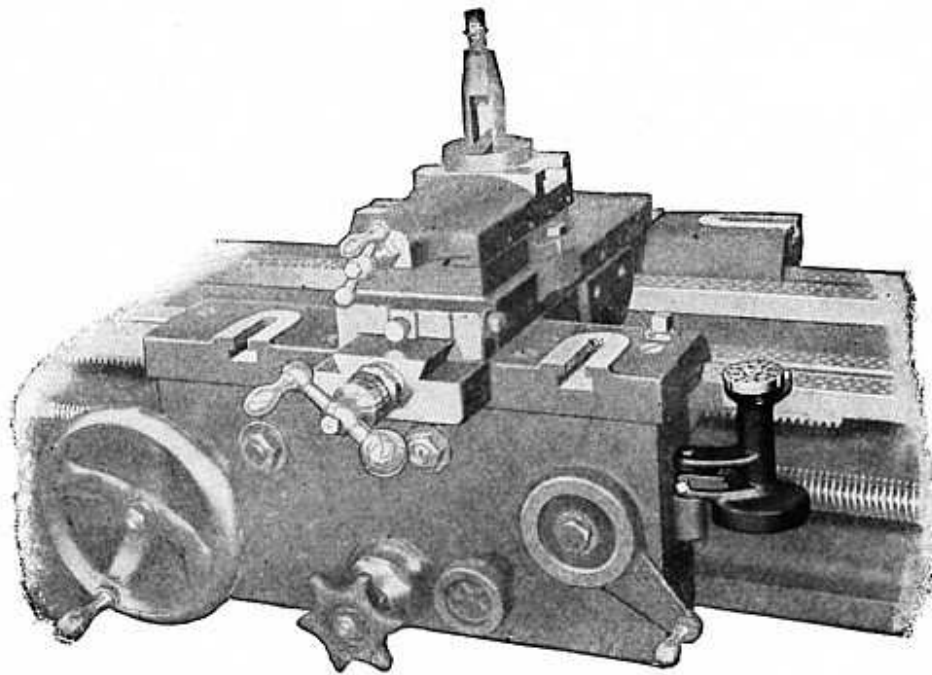

Fig 571

THREAD DIAL ON LATHE

Fig. 571 shows a Threading Dial fitted to the carriage of a lathe. Fig. 572 shows the face of the revolving dial.

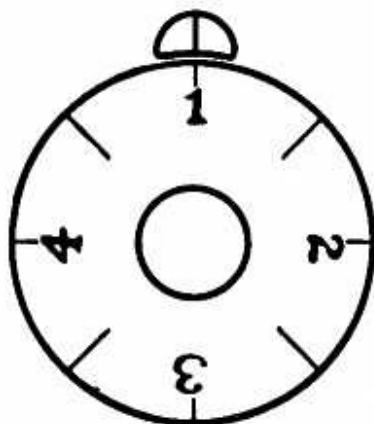

Fig. 572.—Face of Threading Dial

When there are a great many threads to be cut, a Thread Dial is used, as it allows the operator to unclamp the split nut from the lead screw when the end of the thread chip is reached. He can then return the carriage quickly, by hand, to the starting point of the next chip. The thread dial will indicate when to clamp the split nut on the lead screw so that the threading tool will follow in the proper groove for the next chip.

RULES FOR OPERATING THREAD DIAL ON SOUTH BEND LATHE

For all even numbered threads, close the half nuts at any line on the dial. For all odd numbered threads, close the half nuts at any numbered line on dial.

When chasing threads of a pitch involving one-half of a thread in each inch, such as $11\frac{1}{2}$, engage the feed nut at any odd numbered line.

THE SKILLED MACHINIST AND HIS LATHE

The Screw Cutting Lathe is a tool of accuracy and precision. The skilled machinist takes pride in keeping his lathe in first class condition so that he can always turn out accurate work. He knows that if his lathe is given the proper care it will serve him efficiently for a lifetime.

RULE FOR GEARING A LATHE FOR CUTTING SCREW THREADS

One is sometimes called upon to cut a thread on an old lathe from which the index plate has been lost. In this case the following rule will be found useful.

Multiply the number of threads per inch on the lead screw and the number of threads per inch on the bolt to be cut, by any common number that will give for a product the gears that are found with the lathe. For example: We wish to make a bolt having eleven threads per inch. We measure the lead screw and find it has eight threads per inch. Now let us take a common multiple, say 4:

$$\begin{aligned} 4 \times 11, \text{ the thread to be cut, equals } 44; \\ 4 \times 8, \text{ the thread of lead screw, equals } 32. \end{aligned}$$

The gears 44 and 32 are the gears to use. If the thread to be cut is finer than the thread of the lead screw, the smaller gear goes on the spindle stud, while the larger gear goes on the lead screw.

If the gears 44 or 32 are not found in the equipment, multiply by another number, for example, 5 or 6, etc.

Always measure the thread when you take the first chip to be sure you have made no mistake in the gearing.

CUTTING LEFT HAND THREAD

Fig. 573.—The Left Hand Thread

In cutting a left hand thread in the lathe, the directions are the same as for cutting a right hand thread, except in cutting a left hand thread the feed of the carriage is from left to right or toward the tail stock.

In starting a left hand thread on a screw, it is a good plan, if the work will admit it, to drill a hole in the work about the diameter of the pitch of the thread, and about the same depth as the thread. This will give a definite point for starting each chip.

These instructions for left hand thread apply to all types of left hand screw threads.

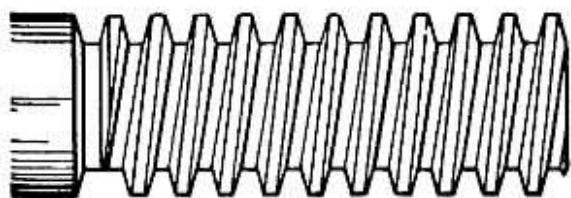
ACME SCREW THREADS

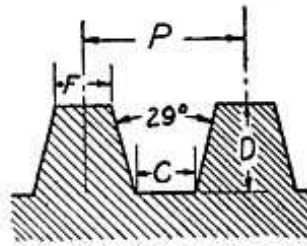
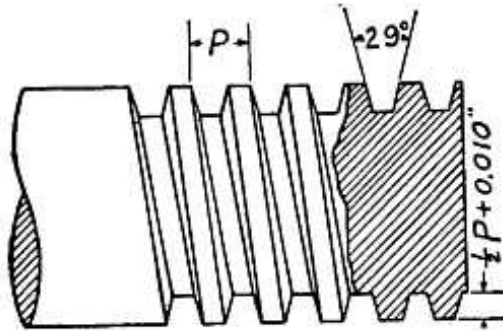

FORMULA

$$P = \text{PITCH} \frac{1}{\text{NO. THDS-PER IN}}$$

$$D = \text{DEPTH} = \frac{1}{2} P + .010$$

$$F = \text{FLAT} = .3707 P$$

$$C = \text{FLAT} = .3707 P - .0052$$

Fig. 574

CUTTING AN ACME SCREW THREAD

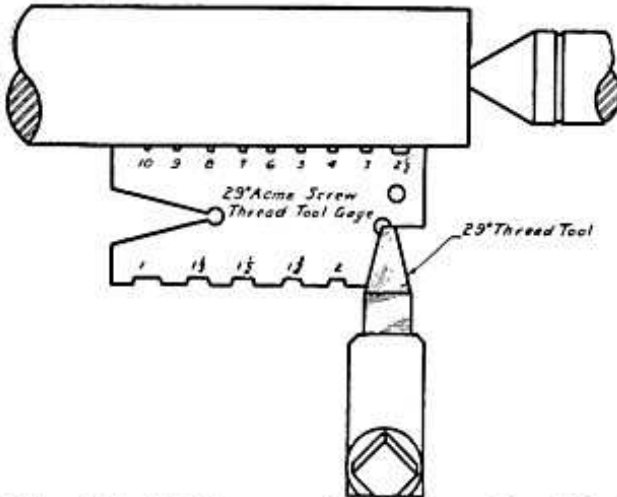

Fig. 575.—Setting an Acme Threading Tool

Fig. 575 shows the method of setting an Acme Threading Tool for cutting an Acme Thread.

If one will place a piece of white paper below the tool on the top of the saddle, the space between the cutting edge of the tool and the gauge can be seen much more clearly.

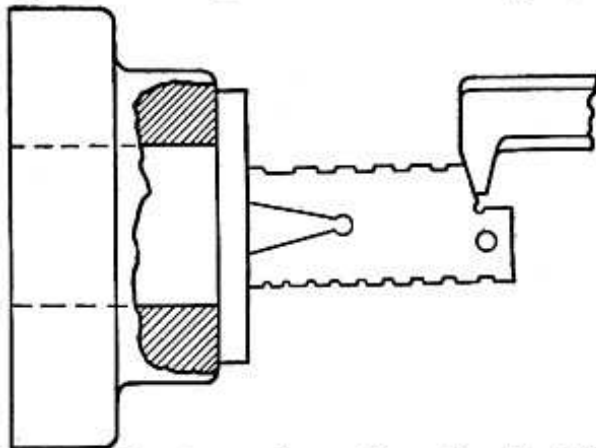

Fig. 576.—Setting an Acme Threading Tool for Internal Threading

INTERNAL ACME THREAD

Fig. 576 shows the method of setting an Acme Threading Tool for internal threading.

A heavy scale or a parallel is set across the face of the work and the legs of the gauge rest on this parallel. Adjust the cutting edge of the tool so that it lines up exactly with the beveled edge of the gauge.

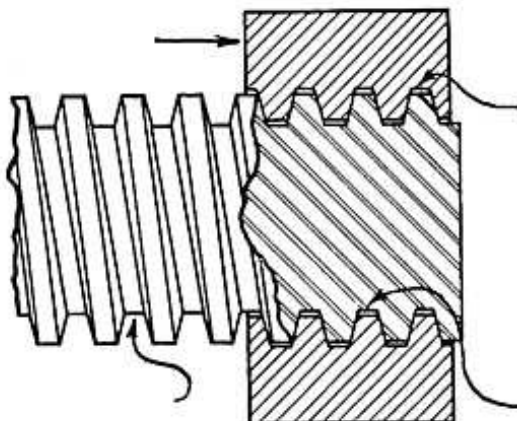
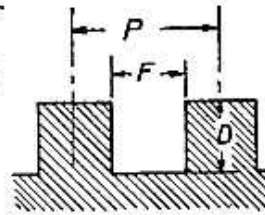
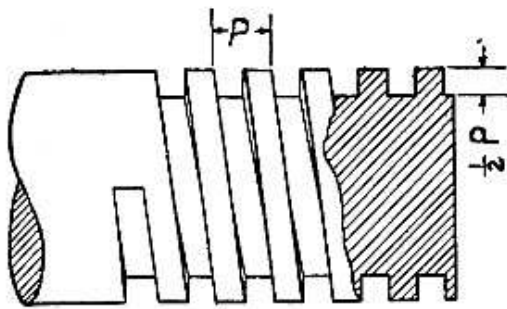

Fig. 577.—Clearance for an Acme Screw Thread

CLEARANCE

In cutting an Acme thread, there should be a clearance of .010" between the diameter at the top of the thread of the screw and the diameter at the bottom of the thread of the nut.



SQUARE THREADS

FORMULA

$$P = \text{PITCH} = \frac{1}{\text{NO. THDS. PER IN.}}$$

$$D = \text{DEPTH} = P \times .500$$

$$F = \text{SPACE} = P \times .500$$

Fig. 578

THE SQUARE SCREW THREAD

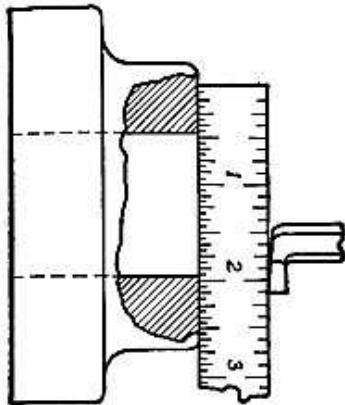

Fig. 579.—Setting the Tool for Square Thread

Fig. 579 shows the method of setting the tool for cutting internal square threads.

The width of the cutting edge of the tool for cutting square screw threads is exactly one-half the pitch, but the width of the edge of the tool for threading nuts is from one thousandth to three thousandths of an inch larger, to permit a sliding fit on the screw.

TOOL FOR SQUARE THREAD

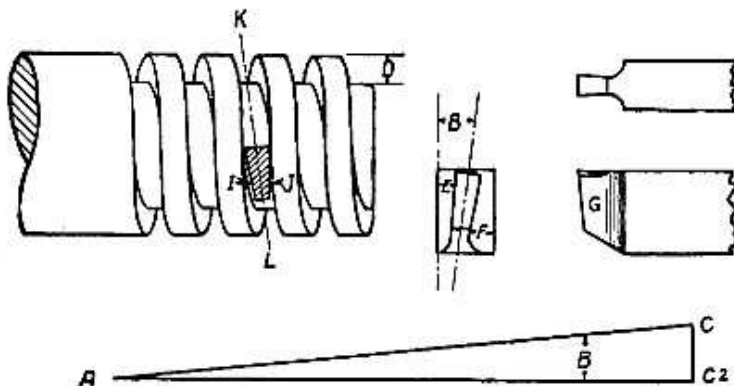

Fig. 580.—Angle of Tool Clearance

Fig. 580 shows the method of arriving at the angle of clearance for making the threading tool.

Draw line A-C2 equal to the circumference of the thread to be cut. Draw line C2-C equal to the lead of the thread and at right angles to line A-C2. Complete the triangle by drawing line A-C. Angle B in the triangle is the helix angle of the thread and the angle to be used in grinding the tool.

The sides of the tool E and F should be given a little clearance when grinding.

CLEARANCE

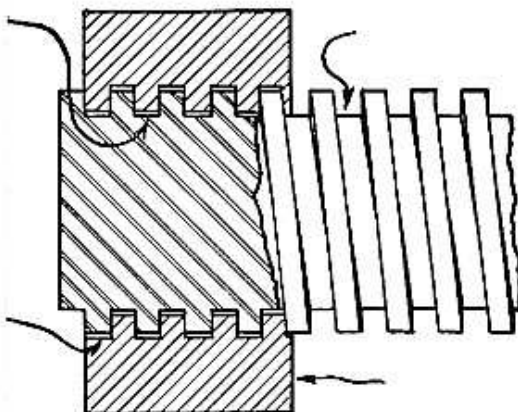

Fig. 581.—Clearance of Diameter

Fig. 581 shows that there should be a clearance between the diameter of the external thread and the diameter of the bottom of the internal thread. This clearance is usually about .005" to .006" for each inch in diameter of the thread.

CUTTING A SCREW THREAD ON TAPERED WORK

The taper attachment of the lathe should be used when cutting a thread on tapered work. If there is no taper attachment with the lathe, the thread on taper can be cut by setting over the tail center.

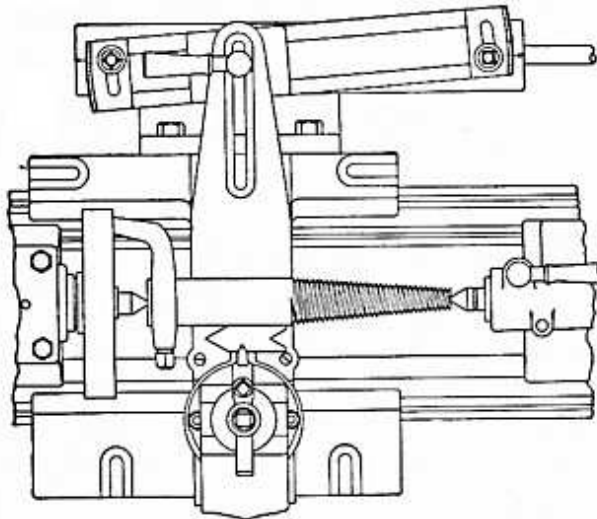

Fig. 582

Fig. 582.—Setting the thread tool for cutting thread on tapered work using the taper attachment.

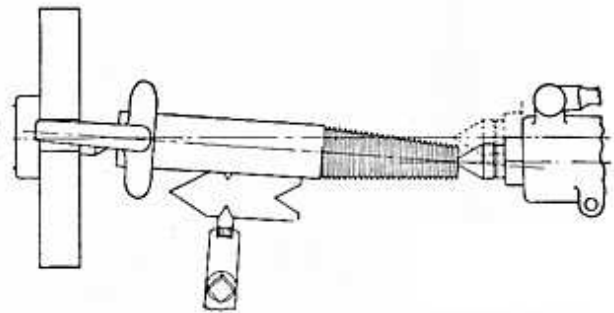

Fig. 582-A

Fig. 582-A shows the method of setting the thread tool for cutting thread on tapered work using the set over tail stock method.

In both the above operations it will be noticed that the outer edge of the thread gauge is set in position on the parallel part of the work.

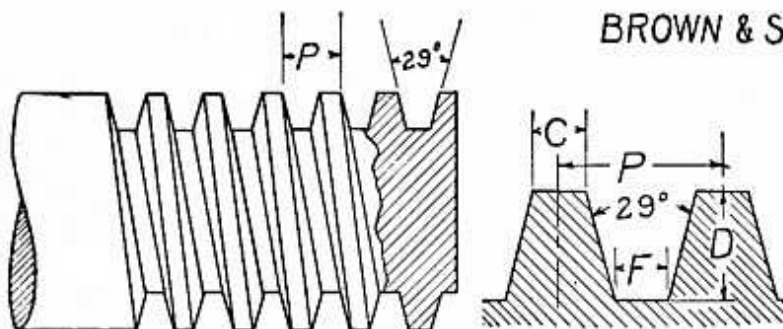

Fig. 583

BROWN & SHARPE 29° WORM THREAD

FORMULA

$$P = \text{PITCH} = \frac{1}{\text{NO. THDS PER IN.}}$$

$$D = \text{DEPTH} = .6866 P.$$

$$F = \text{FLAT} = .31 P.$$

$$C = \text{FLAT} = .335 P.$$

FORMULA FOR BROWN & SHARPE 29° WORM THREAD

Fig. 583 shows a Brown & Sharpe 29° Worm Thread. This is not to be confused with the Acme Standard Thread because it differs from it, for example in: the depth of the thread, the width of the top of the tooth and the width of the bottom of the tooth.

The thread of the worm and the teeth of the worm gear when in mesh are in contact for about three teeth, and to get more perfect contact the thread is made deeper than the Acme Standard Thread.

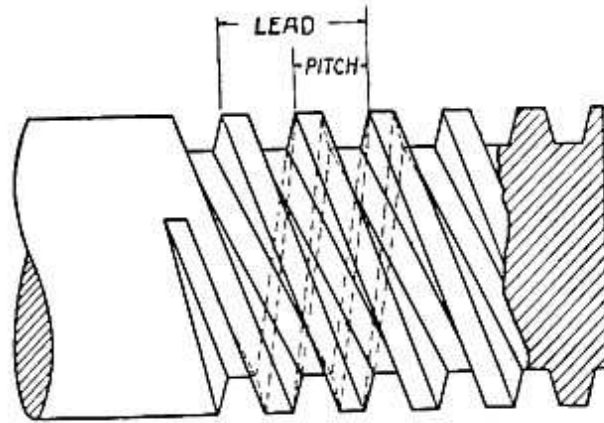

Fig. 584

CUTTING A MULTIPLE THREAD

In cutting a multiple thread between centers, there should be as many slots in the face plate as there are multiples of thread to be cut. For example: to cut a double thread, make two slots in the face plate, one directly opposite the other. It is important that these slots are equidistant from each other in order to divide the threads equally.

Cut each one of the multiple threads exactly in the same manner as you would a single thread. Fasten the dog securely on the work to be cut. Proceed with the cutting as though the screw were a single thread until that thread is finished. Then place the tail of the dog in the opposite slot and proceed with cutting the second thread. The dog must not be removed from the work until both threads have been finished.

If you wish to cut a triple thread, make three equidistant slots in the face plate and proceed as above.

PITCH AND LEAD OF A SCREW THREAD

The pitch of a screw thread is the distance from a point on a screw thread to a corresponding point on the next thread measured parallel to the axis.

$$\text{Pitch (in inches)} = \frac{1}{\text{Number of threads per inch.}}$$

The lead of a screw thread is the distance a screw thread advances axially in one turn. On a single thread screw, the lead and pitch are identical; on a double thread screw, the lead is twice the pitch; on a triple thread screw, the lead is three times the pitch, etc. In cutting multiple threads the lathe should be geared to cut the lead of the thread.

SOUTH BEND — LATHE — M/M THREAD METRIC LATHE			
THREAD	SPINDLE	SCREW	
.50	20	1-2	120
.75	—	30-1-2	-120
1.00	—	30	1-2 90
1.25	—	30-1-2	-72
1.50	—	30	120
2.00	—	30	90
2.50	—	30	72
3.00	—	30	60
3.50	—	42	72
4.00	—	42	63
4.50	—	45	60
5.00	—	45	54
5.50	—	55	60
6.00	—	55	55
6.50	—	52	48
7.00	—	42	36
7.50	—	45	36
8.00	—	48	36

SOUTH BEND LATHE WORKS
SOUTH BEND, IND., U.S.A.

Fig. 585.—The Metric Thread Index

CUTTING METRIC THREADS ON A LATHE WITH A METRIC LEAD SCREW

When a lathe is intended to cut metric threads exclusively, it is equipped with a metric lead screw. The index plate illustrated herewith shows the arrangement of gearing necessary for cutting metric threads on the 18", 21", and 24" South Bend Standard Change Gear Lathes that are equipped with a metric lead screw instead of an American lead screw.

When the lathe is equipped with an American lead screw, and it is desired to cut an occasional metric thread, the use of transposing gears is necessary. The drawing below shows the method of arranging the transposing gears.

CUTTING METRIC THREADS WITH AMERICAN LEAD SCREW

To cut Metric threads on South Bend Standard and Quick Change Gear Lathes, equipped with an American Lead Screw, use the Compound Idler or connecting gears 50 and 127, the No. 127 gear to mesh with the spindle stud. Use an idler to connect the 50 tooth gear with the gear on the lead screw.

When Metric Threads are to be cut, as illustrated, the regular Index Chart of the lathe may be used in selecting gears for the different pitches. Read the chart as so many threads per centimeter, instead of so many threads per inch.

South Bend Standard Change Gear lathes may be equipped with a Metric Lead Screw, instead of an American Lead Screw, at extra cost, if desired.

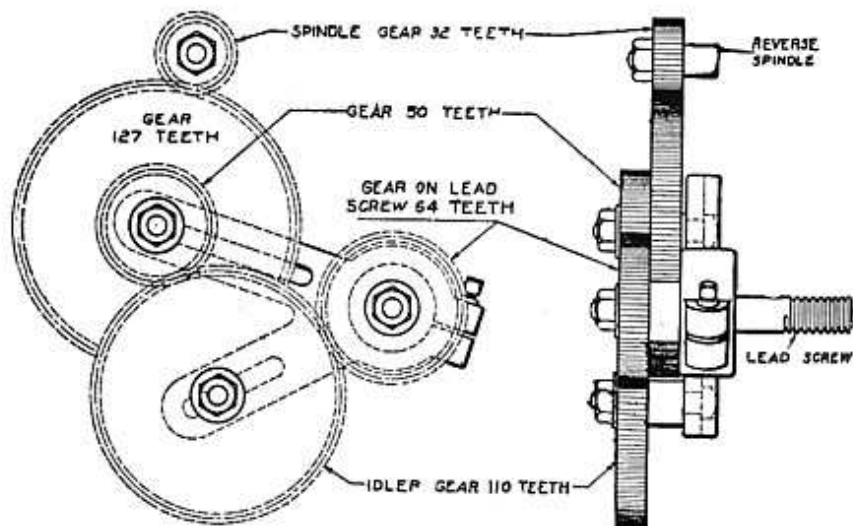

Fig. 586.—Transposing Gears for Metric Thread

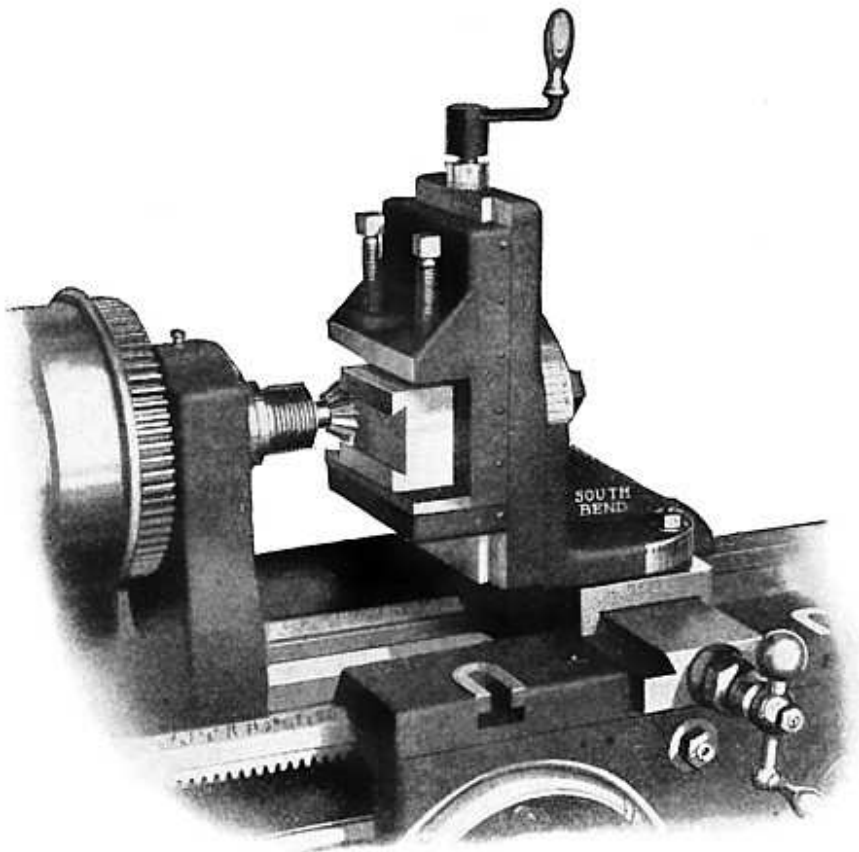

Fig. 587

MILLING AND KEYWAY CUTTING ATTACHMENT FOR THE LATHE

The Milling and Keyway Cutting Attachment illustrated above is a practical tool for the lathe for doing a great deal of work in the small shop that otherwise could be done only on the Milling Machine or the Shaper. This attachment on a lathe operated by an expert mechanic is capable of turning out the finest of work to meet the most accurate requirements.

The depth of the cut is controlled by the feed of the lathe carriage, the length by the cross feed screw; and the graduated screw at the top takes care of the vertical motion. The attachment swivels all the way around like the compound rest and is graduated in degrees. In addition it swivels on the upright angle plate 180 degrees, and is graduated. There is a graduated collar on the vertical screw reading in thousandths of an inch.

This attachment is often used in the manufacture of small duplicate parts on the lathe. A jig for holding the parts is fastened in the attachment vise and the work is machined in the jig.

The attachment is fitted to the saddle cross slide by removing the compound rest top and swivel, and bolting the attachment to the base using the bolts that clamp the compound rest in position.

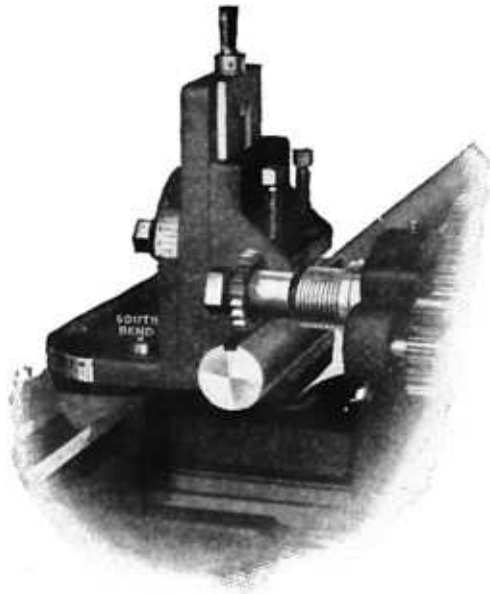

Fig. 588

CUTTING A KEYWAY ON A SHAFT

Fig. 588 shows the application of the milling and keyway cutting attachment cutting a keyway on the shaft in the lathe. It is obvious that by adjusting the shaft in the vise the keyway can be cut the entire length of the shaft, or if a taper shaft is to be milled the vise can be tilted to the desired angle and the keyway can be cut in the shaft as though it were straight.

SQUARING OF A STEEL SHAFT

Fig. 589 illustrates the squaring of a shaft held in the milling attachment of the lathe. A spiral end mill with Morse Taper shank is held in the spindle of the lathe. This is an excellent method of milling squares, hexagons and flats, because the end mill cuts a clean true surface.

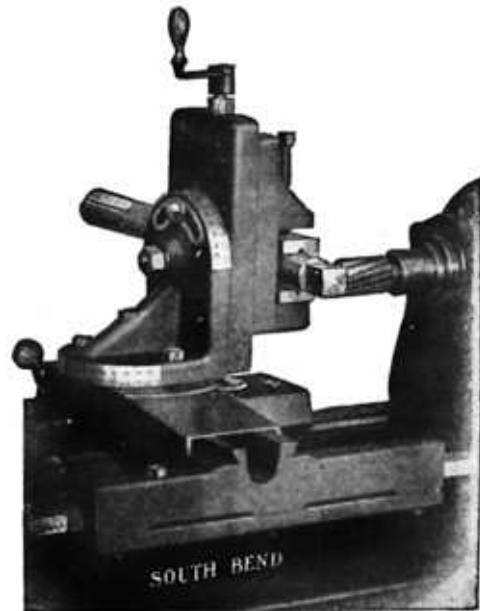

Fig. 589

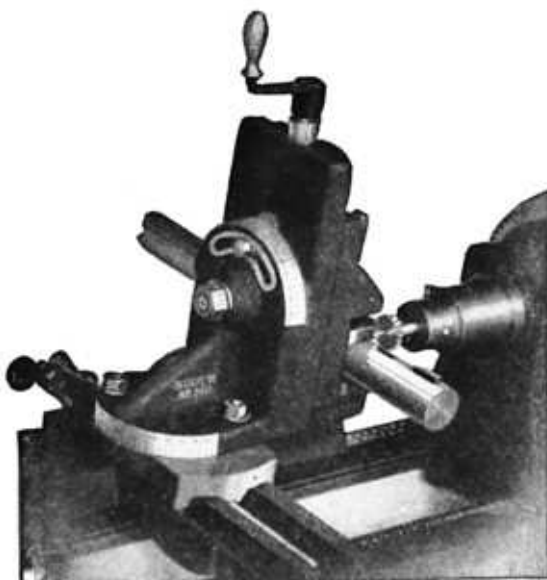

Fig. 590

MILLING A WOODRUFF KEYWAY

Fig. 590 shows the method of milling a Woodruff Keyway in a shaft. The Woodruff cutter is held in a blacksmith's drill chuck that fits the taper of the lathe spindle.

A MILLING ARBOR

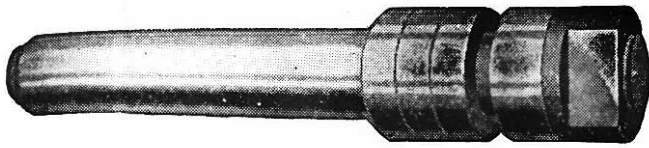

Fig. 591

Fig. 591 illustrates a milling arbor for use in the head spindle of the lathe. This arbor has adjustable collars and is similar to the regular milling machine arbor for holding milling cutters of various sorts.

SPIRAL END MILL FITTED WITH MORSE TAPER

Fig. 592 is a spiral end mill fitted with Morse Taper to fit in the head spindle, and if a smaller taper, it can be fitted to a reducing socket, the outside of which fits the spindle of the lathe.

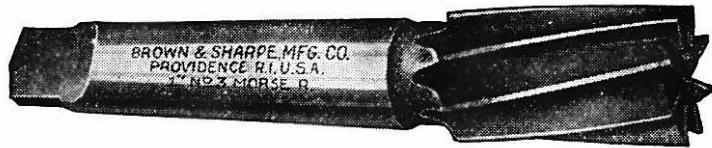

Fig. 592

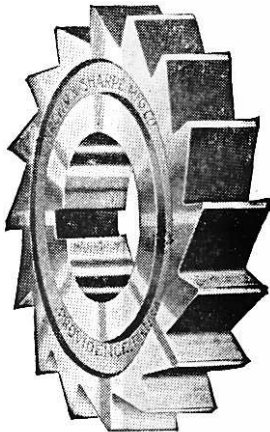

Fig. 593

A FACE MILLING CUTTER

Fig 593 is a face milling cutter that is held on the milling arbor for doing face milling.

A SIDE MILLING CUTTER

Fig. 594 is a side milling cutter that is held in the arbor. This cutter will mill on either side as well as on the face.

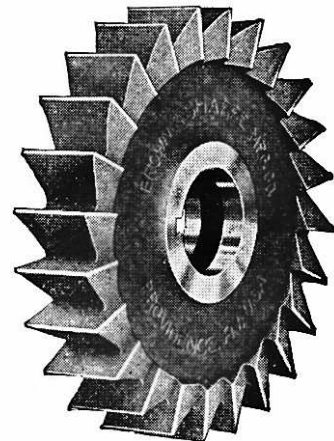

Fig. 594

A MILLING CUTTER FOR MILLING WOODRUFF KEYWAYS



Fig. 595—Woodruff Keyway Cutter

Fig. 595 is a milling cutter for milling Woodruff System of Keyways. This is a face milling cutter and is held by a blacksmith's chuck which fits the head spindle of the lathe.

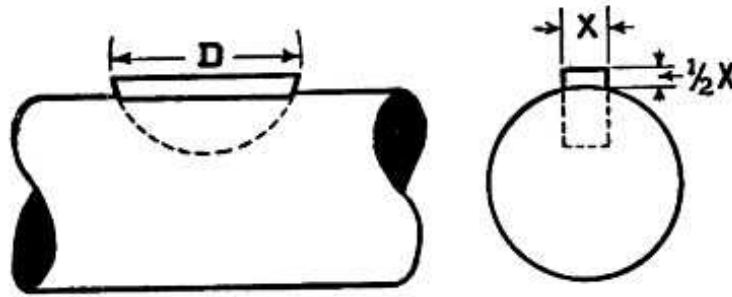

Fig. 596

WOODRUFF KEYWAY

The drawing herewith shows a shaft that has been milled for a Woodruff key, with key inserted. "X" equals the thickness of key. The key should project above the shaft one-half its thickness.

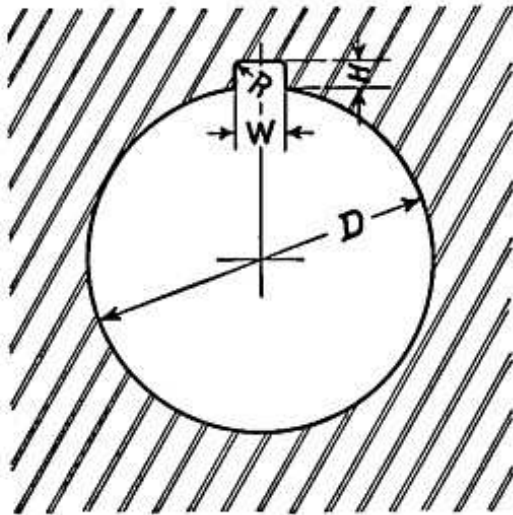

Fig. 597

STANDARD KEYWAYS FOR PULLEYS AND SHAFTS

This diagram shows the recognized standard for the depth and width of keyway in pulleys. The same formula, of course, may be used for the depth and width of keyway in shaft.

Here we give a list of the standard sizes of keyways both for pulleys and shaft.

Diameter (D) of Hole	Width (W) of Keyway	Depth (H) of Keyway	Radius (R)
$\frac{3}{8}$ " to $\frac{9}{16}$ "	$\frac{3}{32}$ "	$\frac{3}{64}$ "	
$\frac{5}{8}$ " to $\frac{7}{8}$ "	$\frac{1}{8}$ "	$\frac{1}{16}$ "	.030
$\frac{15}{16}$ " to $1\frac{1}{8}$ "	$\frac{5}{32}$ "	$\frac{5}{64}$ "	.035
$1\frac{3}{16}$ " to $1\frac{3}{8}$ "	$\frac{3}{16}$ "	$\frac{3}{32}$ "	.040
$1\frac{7}{16}$ " to $1\frac{3}{4}$ "	$\frac{1}{4}$ "	$\frac{1}{8}$ "	.050
$1\frac{13}{16}$ " to 2"	$\frac{5}{16}$ "	$\frac{5}{32}$ "	.060
$2\frac{1}{16}$ " to $2\frac{1}{2}$ "	$\frac{3}{8}$ "	$\frac{3}{16}$ "	.060
$2\frac{9}{16}$ " to 3"	$\frac{7}{16}$ "	$\frac{3}{16}$ "	.060

When filing in the lathe never use a file without a handle. Do not knock a file on the ways of the lathe to free it from chips.

Do not rotate a hand reamer or machine reamer backwards because it will dull the edge of the teeth.

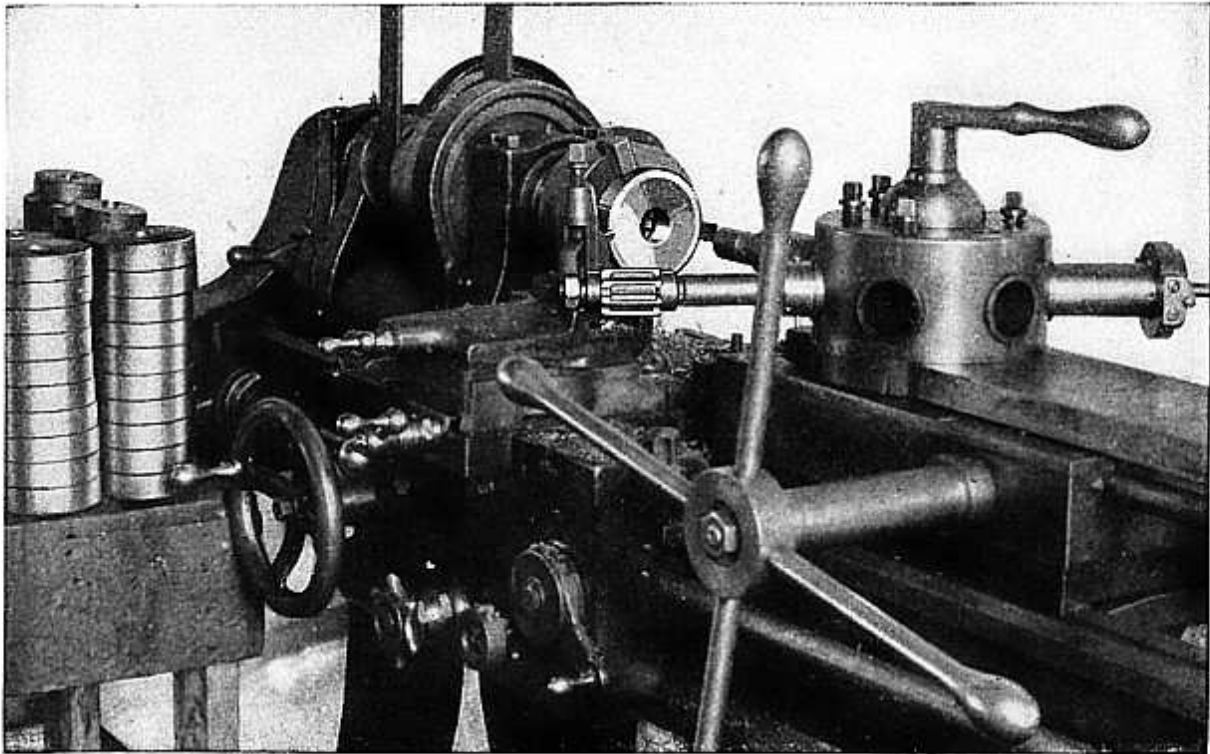

THE LATHE AS A TURRET LATHE FOR CHUCKING WORK

The lathe fitted with a turnstile turret makes an excellent chucking machine for manufacturing. While the work is held in the chuck, a tool may be used in the tool post using the carriage feeds for facing or turning, and the turret tools can be in operation at the same time, operated by an automatic feed on the turret slide.

The illustration shows a screw cutting lathe fitted with a turnstile turret on the bed for chucking work. The turret is bored to receive six different tools. The job illustrated is that of machining steel discs. The tools in the turret are: a centering tool, a drill, a boring tool, and a reamer.

The work is held in a 3-jaw Universal Chuck while attached to the spindle of the lathe. While the work is being machined by the various turret tools a facing tool held in the tool post fed by the automatic cross feed screw machines the face of the work.

The above equipment for some work can be increased by adding a double tool rest, one tool in front for facing and one tool in the back for forming or cutting.

A lathe equipped in this way serves the purpose of a special automatic machine, and when the job is finished, the attachments can be removed and the lathe can be used for general work.

The above illustration is taken from a photograph in our own shop where we have a number of South Bend Screw Cutting Lathes in use as turret lathes for chucking work.

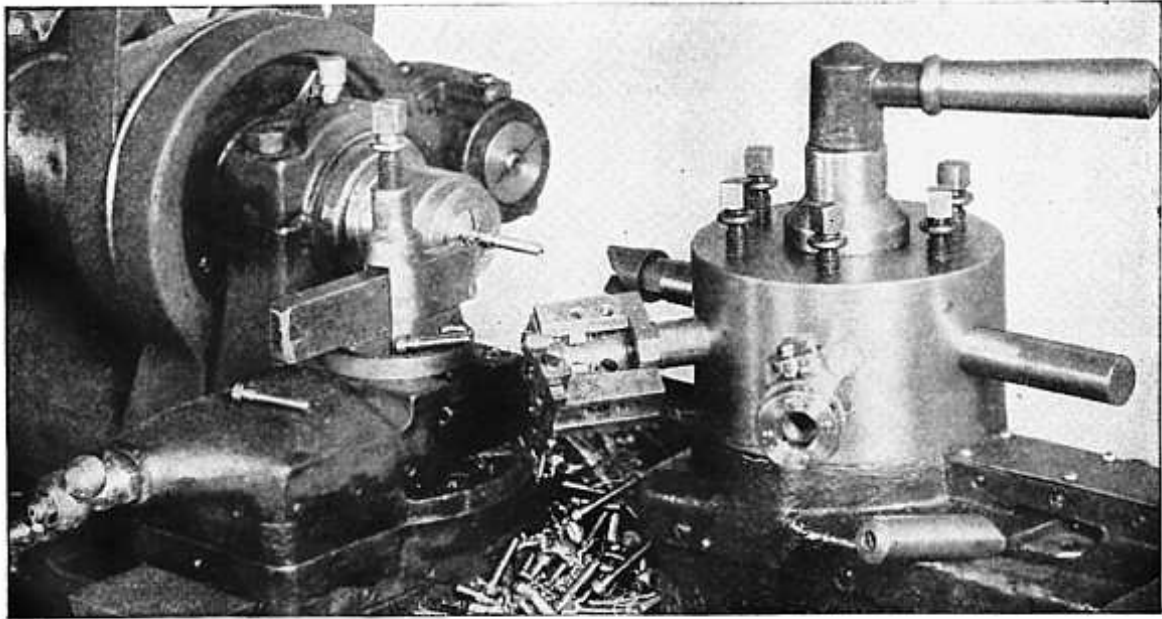

Fig. 610.—A screw cutting lathe fitted with hand lever closing device for Draw-in Chuck Attachment and hand lever turret, for making small screws. Note the box tool and the threading die.

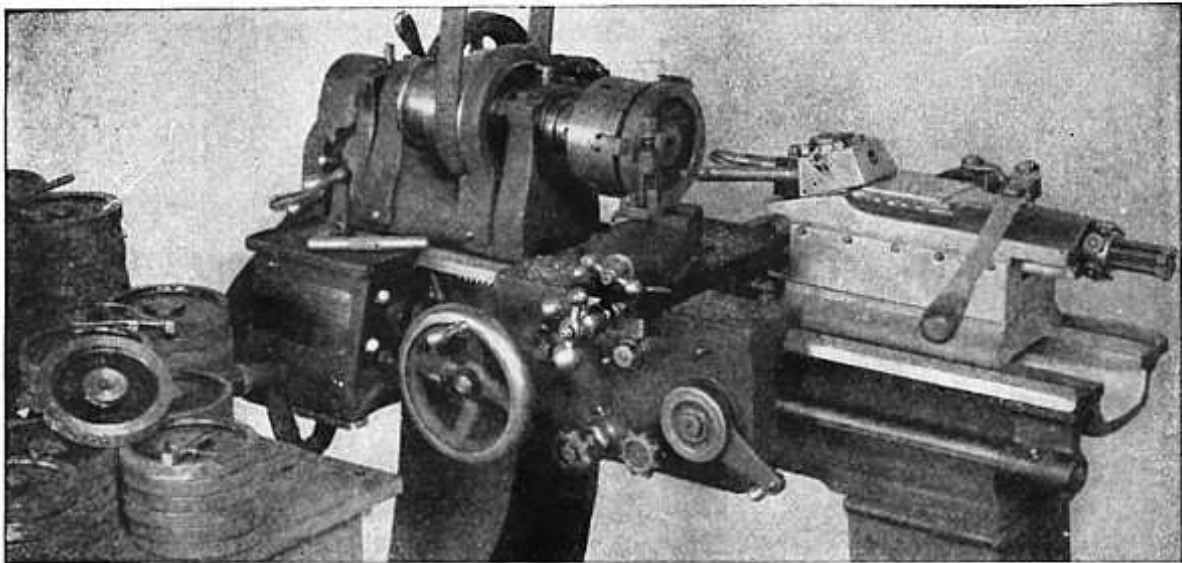
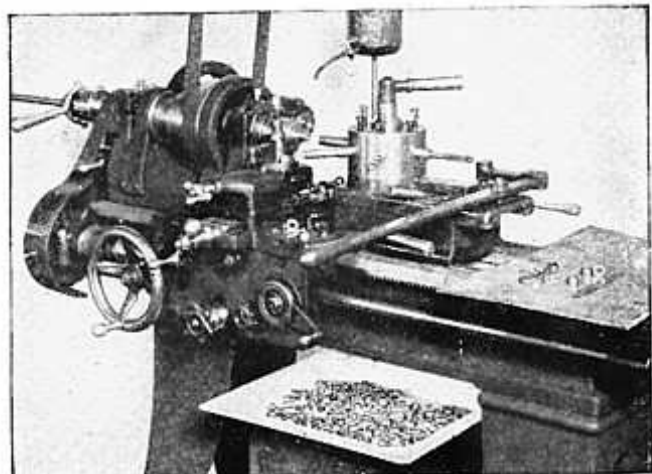

Fig. 611.—Screw cutting lathe fitted with a hand lever turret for machining small gear blanks.

Fig. 612 shows an 11" Screw Cutting Lathe equipped with a hand lever turret slide on bed, and a hand lever closing device for the draw-in chuck attachment. The lathe shown is equipped for making small brass machine screws.



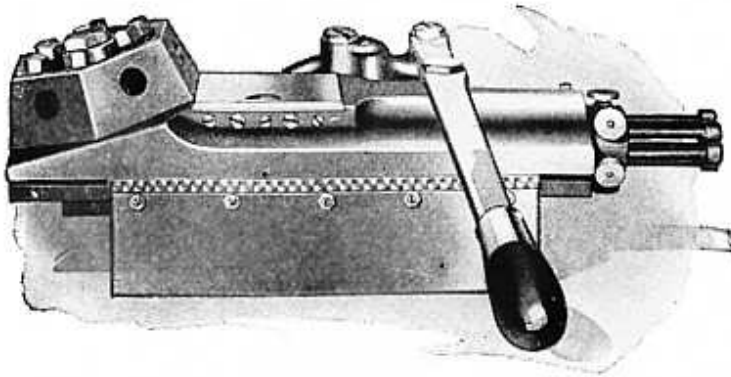

Fig. 604.—The Hand Lever Turret

be seen at the right end of the turret slide. The hand lever turret revolves one-sixth of a turn each time the lever is pushed back beyond the latch.

THE TURRET ON SADDLE

Fig. 605 shows the application of the turret on the saddle of the lathe. This saddle turret is semi-automatic and must be revolved by hand. In using a saddle turret on the lathe, the center of the turret holes should line up with the axis of the head spindle and there should be a gauge or a stop on the saddle so that the turret hole would line up with the spindle hole in the operation of each tool. Sometimes the turret is located in position by a taper pin which fits into a hole drilled through the turret base and saddle top.

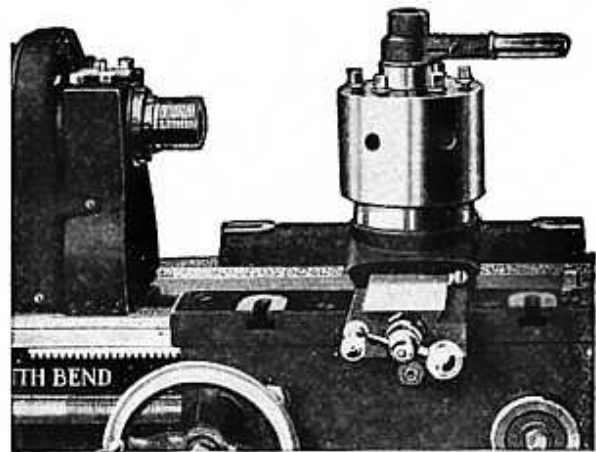

Fig. 605.—The Turret on Saddle

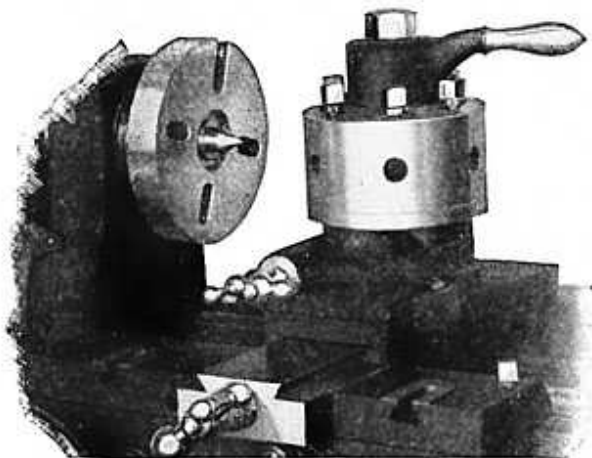

Fig. 606.—The Tool Post Turret

THE HAND LEVER TURRET

Fig. 604 shows the application of a hand lever turret that can be attached to the bed of an 11" lathe. Each one of the six tools has a stop that can be set to allow each tool to be fed a certain distance only. The six stops may

TOOL POST TURRET

Fig. 606 shows the application of a tool post turret held in the compound rest of the lathe. It is semi-automatic and must be revolved by hand after each tool has been in action. There should be a similar gauge or a stop on the saddle in operating the tool post turret so as to always bring the operating tool to the center or axis of the lathe spindle.

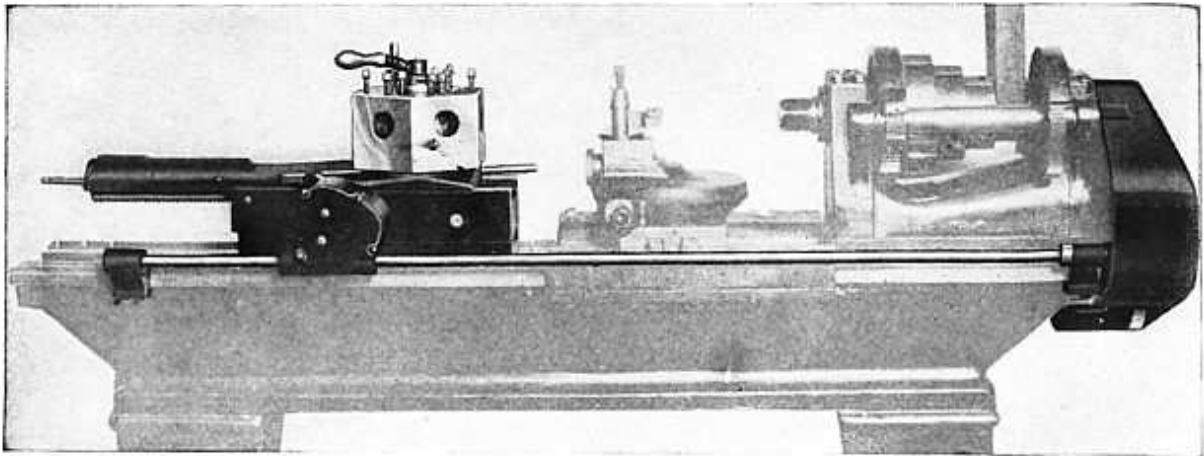

Fig. 607

AUTOMATIC FEED FOR TURNSTILE TURRET SLIDE

Fig. 607 shows the method of applying an automatic feed to a turnstile turret slide fitted to the bed of a screw cutting lathe. A shaft is attached by two brackets to the rear way of the lathe bed, one end of this shaft is geared to connect with the change gears at the head end of the lathe, the other end is splined to receive a worm which drives the automatic feed of the turret slide.

SCREW CUTTING LATHE ON SPECIAL JOBS

Many expert machinists are using the screw cutting lathe on special manufacturing jobs. By the use of jigs a great deal of accurate work of various kinds is being machined in the lathe. After the job is done the jigs and tools are put away and other jigs and tools are attached, or the lathe may be used as a regular screw cutting lathe.

Fig. 608.—Turnstile turret fitted to a 24" screw cutting lathe machining heavy work.

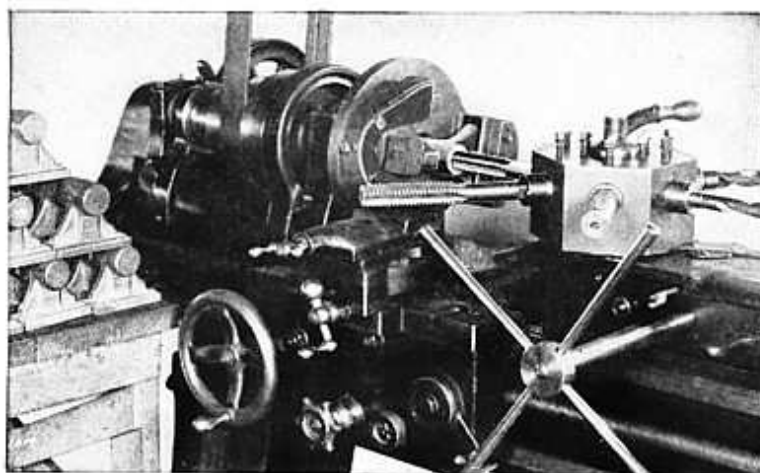
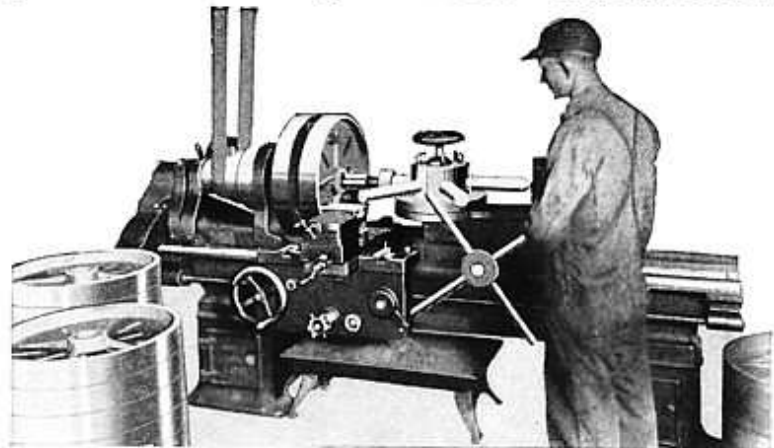

Fig. 609.—Turnstile turret fitted to an 18" lathe for drilling, reaming and tapping of half nuts.

THE USE OF THE BORING BAR IN THE LATHE

A lathe is an excellent machine in which to do accurate boring with a boring bar.

The boring bar is held between centers and driven by a dog. The work is clamped to the top of the lathe saddle and is fed to the tool by the automatic longitudinal feed of the carriage.

STYLES OF BORING BARS

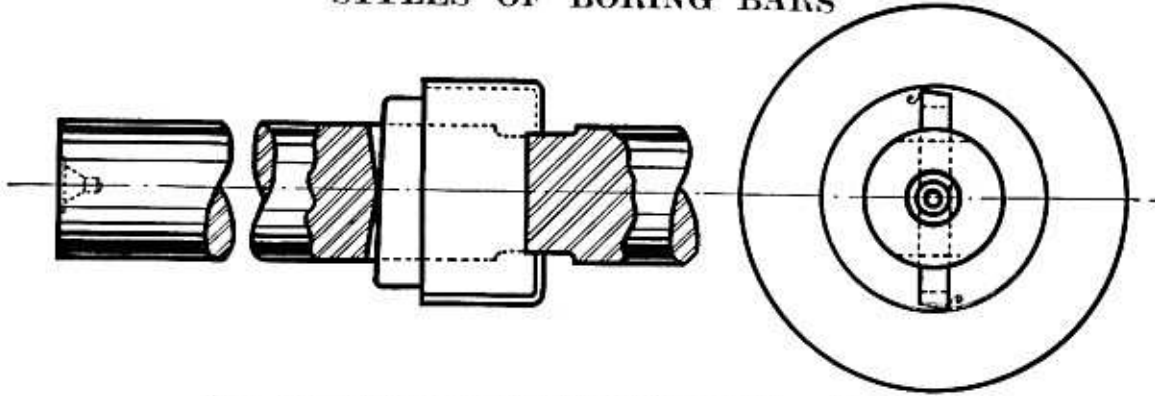

Fig. 613.—Boring Bar for Finishing or Sizing the Hole

Fig. 613 shows a boring bar fitted with a two edge cutter held by a taper key. This is more of a finishing or sizing cutter, as it cuts on both sides and is used for production work.

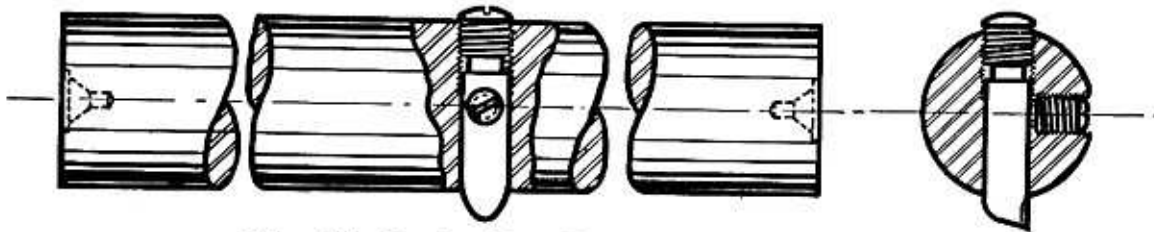

Fig. 614.—Boring Bar Fitted with a Fly Cutter

Fig. 614 shows a boring bar usually used in jobbing work. It is fitted with a fly cutter held by a headless set screw. There is another headless set screw at the end of the cutter for adjusting it to the work.

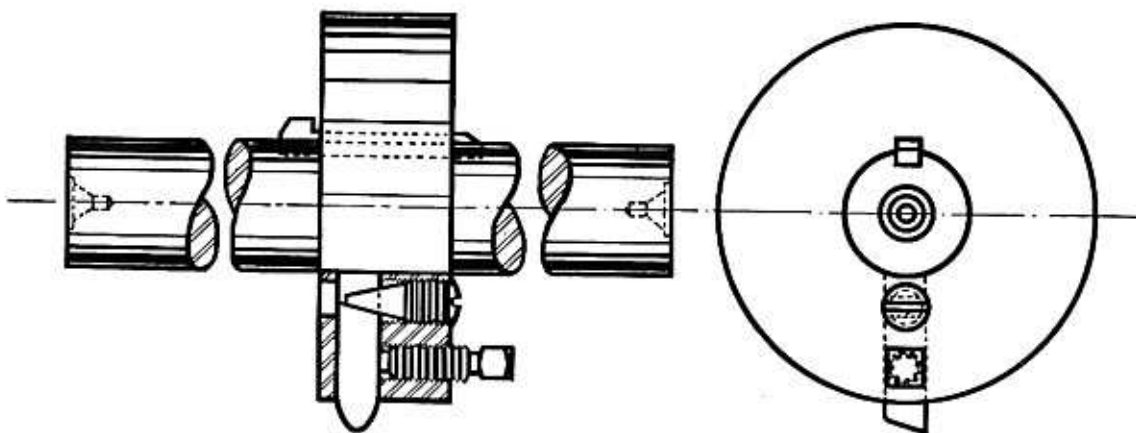

Fig. 615.—Boring Bar Fitted with a Cast Iron Boring Head

Fig. 615 shows a boring bar fitted with a cast iron head. The head is fitted with a fly cutter and is designed for boring work of large diameter.

DRILLING, REAMING AND TAPPING IN THE LATHE

Using the Lathe as a Drill Press

The screw cutting lathe is an excellent machine for drilling work and it is used for this class of work in many manufacturing plants.

Drilling in a lathe has the advantage of the drill operating in a horizontal position which has a tendency to clear itself of chips. When the work is revolving and the drill is held stationary, one can also get a true hole.

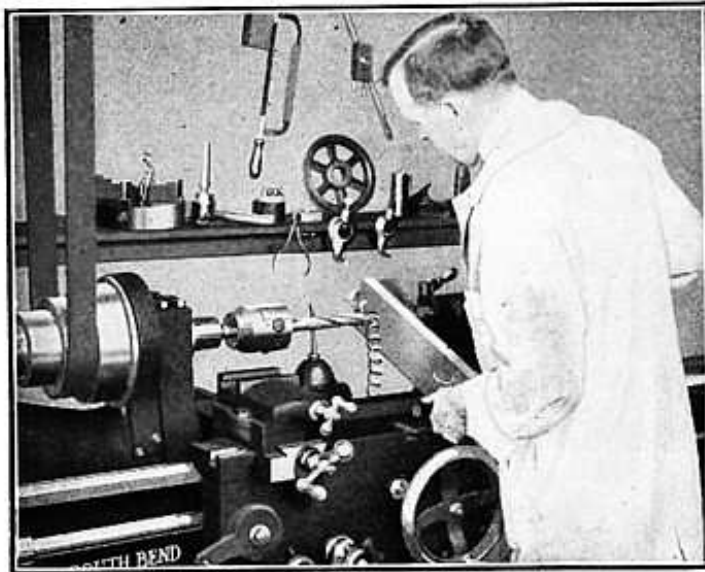

Fig. 619.—Operation of a Drilling Job

Drilling in the Lathe

Fig. 619 shows a drilling operation with a drill chuck in the head spindle. The work being drilled is a steel bar, which is fed to the drill by the hand wheel of the tail stock.

Drill Grinding Gauge

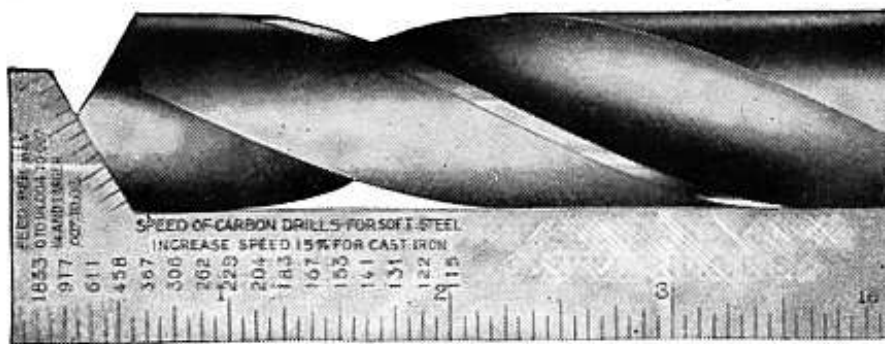

Fig. 620.—Drill Grinding Gauge

Fig. 620 shows a gauge for the grinding of drills. In grinding a drill it is very necessary that the cutting lips be of the same angle and that the angle at the point of the drill be correct.

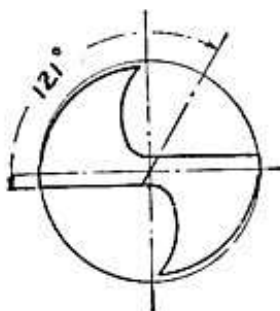

Fig. 621.—Correct Angle of Drill Point

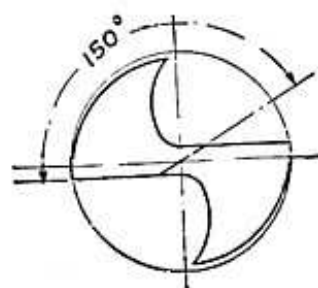

Fig. 622.—Incorrect Angle of Drill Point

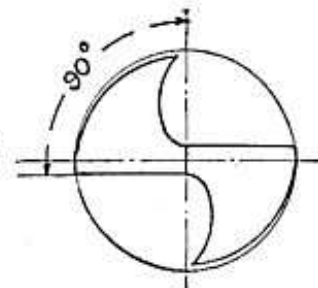

Fig. 623.—Incorrect Angle of Drill Point

REAMING AND TAPPING IN THE LATHE

Fig. 624.—Reaming in the Lathe

Fig. 624 shows the application of the machine reamer in the lathe. The reamer is held in a special holder which has a hand lever control.

USING A MACHINE REAMER IN THE LATHE

Fig. 625.—Using a Machine Reamer in the Chuck

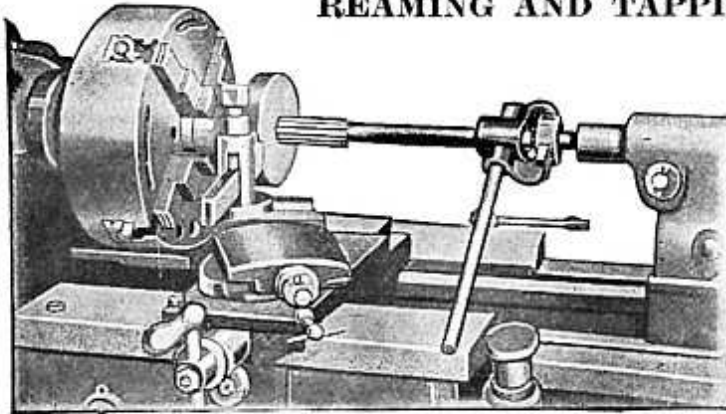
Fig. 625 shows the application of a lathe chuck holding work and a drill chuck in the tail stock spindle holding a machine reamer. The reamer is fed through the work by the tail stock hand wheel.

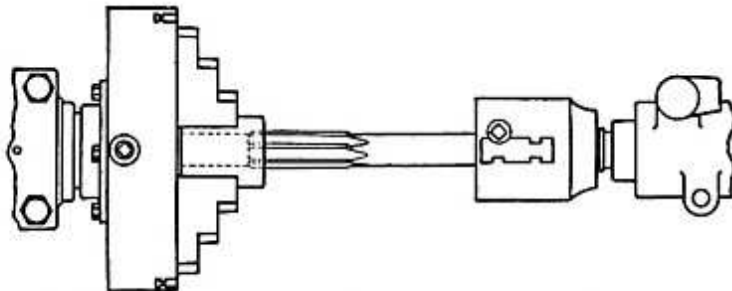
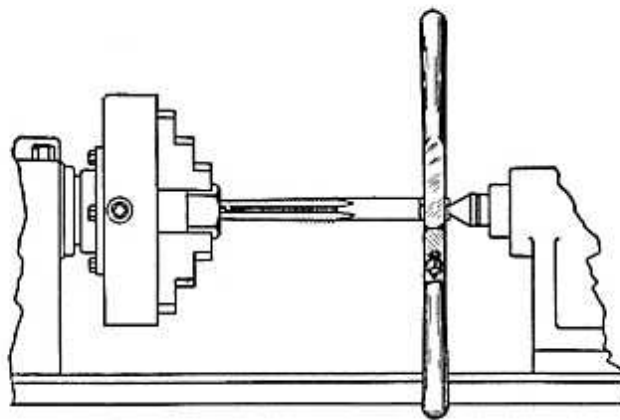

Fig. 626.—Tapping in the Lathe

TAPPING IN THE LATHE

Fig. 626 shows the tapping of a nut in the lathe. The taper end of the tap is placed in the nut which is held in the lathe chuck. A tap wrench is placed on the tap on the tail center. The spindle is started on slow speed and the tap may be fed in with hand wheel of the tail stock, or for light work the entire tail stock may be pushed by hand.

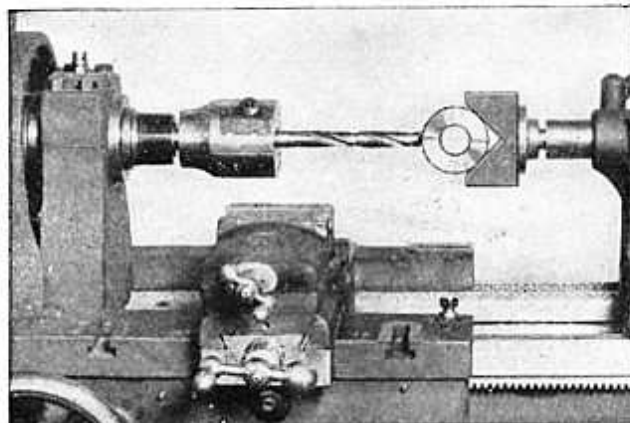

Fig. 627.—Drilling Through the Diameter of a Cylinder

DRILLING THROUGH THE DIAMETER OF A CYLINDER WITH THE AID OF A CROTCH CENTER

Fig. 627 shows the application of a drill chuck in the head stock spindle and a crotch center in the tail spindle, drilling through the diameter of a cylinder or collar.

This is an excellent method of drilling round work.

THE ELECTRIC GRINDER

The illustration shows an Electric Grinder mounted on the Compound Rest of the Lathe and driven from an ordinary light socket. Being attached to the Compound Rest the Grinder can be swiveled to any angle for grinding taper shafts or cutters and for internal grinding in taper holes.

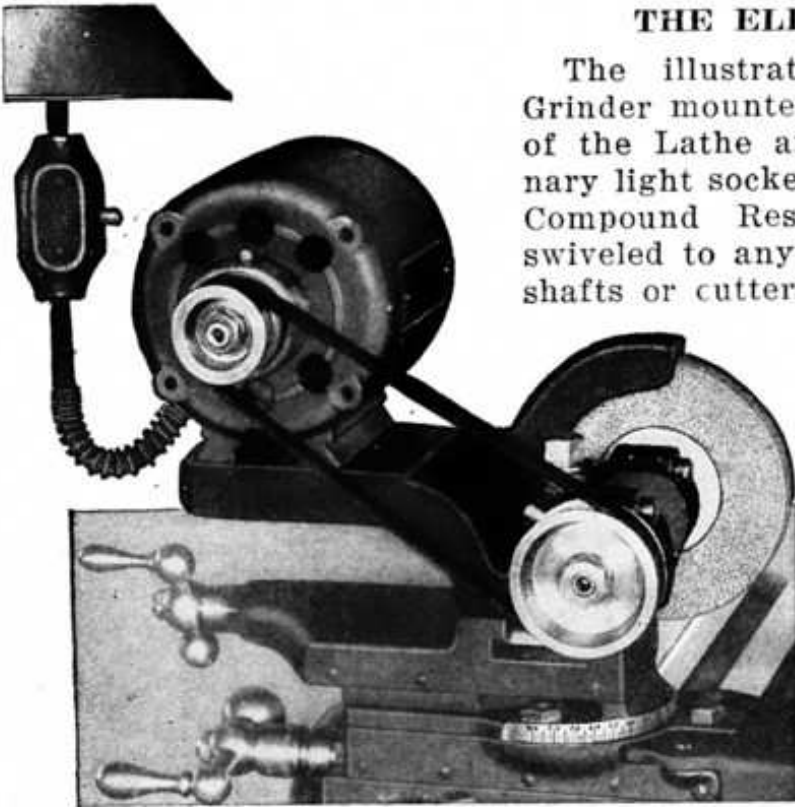

The small Electric Grinder is a useful Attachment for a Lathe, on such work as grinding and sharpening all kinds of reamers, cutters, straight, taper or spiral, also for internal grinding of small hardened bushings, etc.

The operation of a Grinding Attachment on a Lathe presents some problems to the beginner. It is not the purpose of the small Grinder to take heavy cuts on the work or remove excessive stock. On the contrary, the Grinder should be used only to take light or finishing cuts because the emery wheel is small and runs at high speed so that in taking a heavy cut the wear on the wheel is oftentimes greater than the amount of stock removed from the work in each cut.

The Depth of the Grinding Cut

In using the Grinder equipped with a wheel from 4" to 6" in diameter, the depth of the cut should not be more than .001" or .002". That is, the diameter of the work should not be reduced more than .002" to .004" on each cut. On the finishing cut .001" to .0015" on the diameter of the work will leave a better finish. It is sometimes a good plan on cylindrical grinding to take one or two finishing cuts without making any adjustment on the wheel.

Machine the Work Instead of Grind Whenever Possible

Grind the work only when it cannot be machined, for example: when the work has been hardened or tempered such as cutters, reamers, taps, etc., then we must grind, but on material such as soft steel, cast iron and other metals it is much better to machine the work than grind, as it is much quicker, especially with the type of grinder used in the machine shop and service station.

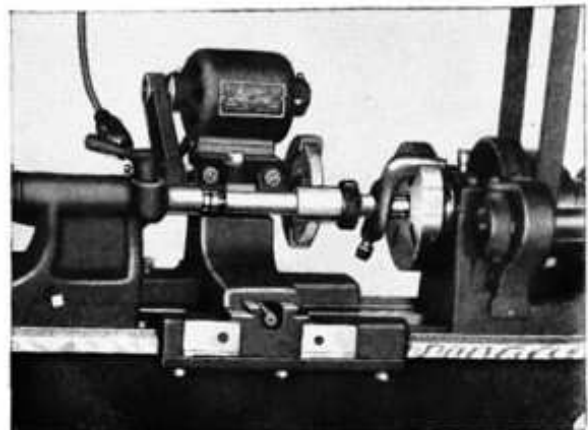

Grinding a Hardened Steel Bushing

TRUING THE GRINDING WHEEL

A Grinding Wheel of 4" to 6" in diameter in continuous work will need truing up at least every half hour and sometimes oftener, depending upon the work. The way to true the wheel is with a black or commercial diamond as shown in the illustration. The diamond is held in a fixture, the revolving wheel is brought up to the diamond point and fed slowly across the face of the diamond. Two or three cuts is sufficient to true the wheel properly.

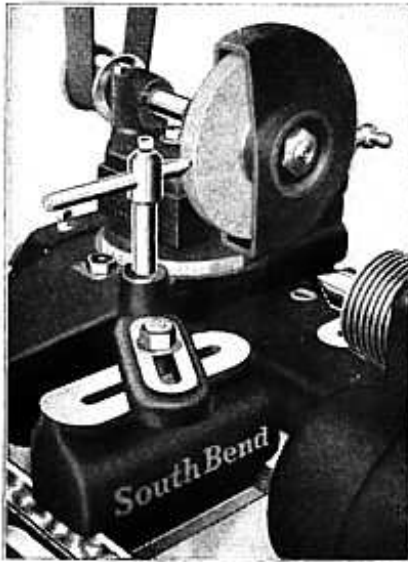

Truing a Grinder Wheel

DIAMOND HOLDER AND SPRING CUTTERSTOP



Diamond Dresser for Truing Emery Wheel

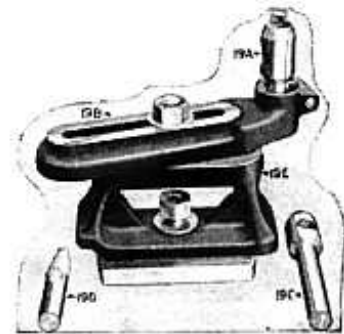

Fixture for Holding Spring Stop and Diamond Dresser

EMERY WHEEL SPEEDS

Grinding wheels are run in actual practice from 4,000 to 6,000 feet surface speed per minute.

Below we give the number of revolutions of wheels of different diameter for 4,000 and 5,000 feet surface speed per minute.

Diam. Wheel	1 in.	2 in.	3 in.	4 in.	5 in.	6 in.	7 in.	8 in.	10 in.	12 in.
R.P.M. for surface Speed of 4,000 ft.....	15,279	7,639	5,093	3,820	3,056	2,546	2,183	1,910	1,529	1,273
R.P.M. for surface Speed of 5,000 ft.....	19,099	9,549	6,366	4,775	3,820	3,183	2,728	2,387	1,910	1,592

GRINDING WHEELS FOR VARIOUS KINDS OF WORK

There are various grades of emery or grinding wheels, all of which are marked for special kinds of work such as cast iron, steel, grinding hardened tools, etc. We herewith show a tabulation showing the grain and grade of wheels for different work.

Kind of Work	Name of Wheel	Grain	Grade
Cast Iron.....	Crystalon	36	K
Steel	Alundum	46	M
Cutting Tools.....	Alundum	19	50-K
Valves	Alundum, Shellac.....	60	3

PRACTICAL GRINDING JOBS

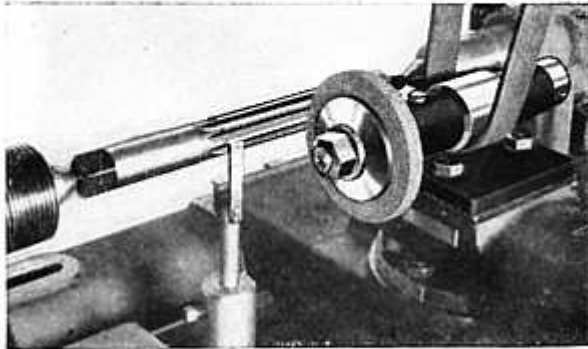

Grinding a Straight Reamer

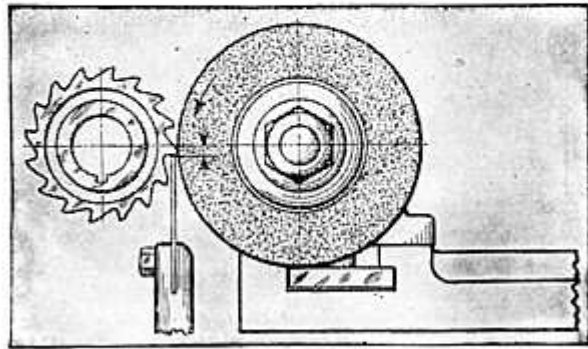

Grinding Clearance on a Milling Cutter

The grinding or sharpening of hardened reamers or cutters, straight and bevel, requires care and skill on the part of the operator. The cut should be light; the adjusting stop that regulates the position of the cutting edge of the reamer flute should be set accurately so as to get the proper clearance on the cutting edge; the emery wheel should be of the right grade and have the proper speed and run true.

Grinding Angular Cutters in the Lathe

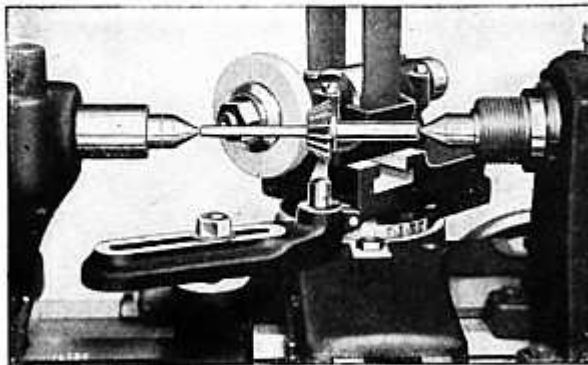

Grinding an Angular Cutter in the Lathe

The illustration shows the method of grinding angular cutters in the Lathe. The Cutter is placed on an arbor that is a snug fit and then mounted between centers in the Lathe. Set the Compound Rest to the proper angle or taper of the cutter. Set the clearance stop to the proper height. Holding the cutter against the stop by one hand. Feed the grinding wheel across the cutting edge of the flute. Repeat the operation on each flute.

Be careful not to take too deep a cut or it may heat the cutter and draw the temper.

Internal Grinding Spindle

The illustration shows the No. 15 Grinder set for internal grinding on the Lathe. Note that for this operation the pulleys of the Grinder have been transposed. This permits higher speed on the internal grinding spindle.

A speed of 10,000 R.P.M. may be obtained by fitting larger pulley on the armature shaft. Internal grinding attachment is used for the grinding of holes in hardened cutters or small bushings of various kinds. Great care should be taken here to see that the wheel does not take too great a cut as the cut should be as light as possible to prevent wear on the grinding wheel.

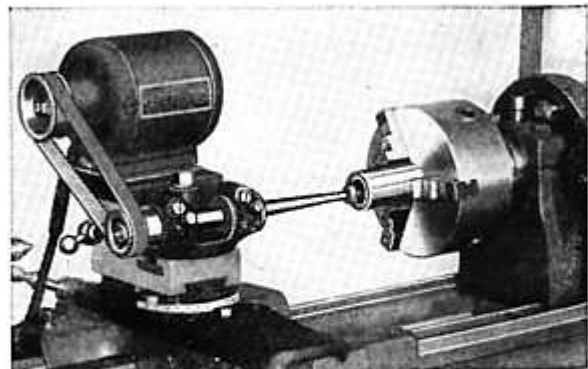

Grinding the inside of a steel bushing

TABLE OF DECIMAL EQUIVALENTS
of 8ths, 16ths, 32nds and 64ths of an inch

8ths.	16ths.	32nds.	
$\frac{1}{8} = .125$	$\frac{1}{16} = .0625$	$\frac{1}{32} = .03125$	$\frac{1}{64} = .015625$
$\frac{1}{4} = .250$	$\frac{2}{16} = .125$	$\frac{2}{32} = .0625$	$\frac{2}{64} = .03125$
$\frac{3}{8} = .375$	$\frac{3}{16} = .1875$	$\frac{3}{32} = .09375$	$\frac{3}{64} = .046875$
$\frac{1}{2} = .500$	$\frac{4}{16} = .250$	$\frac{4}{32} = .125$	$\frac{4}{64} = .0625$
$\frac{5}{8} = .625$	$\frac{5}{16} = .3125$	$\frac{5}{32} = .15625$	$\frac{5}{64} = .078125$
$\frac{3}{4} = .750$	$\frac{6}{16} = .375$	$\frac{6}{32} = .1875$	$\frac{6}{64} = .09375$
$\frac{7}{8} = .875$	$\frac{7}{16} = .4375$	$\frac{7}{32} = .21875$	$\frac{7}{64} = .109375$
	$\frac{8}{16} = .500$	$\frac{8}{32} = .250$	$\frac{8}{64} = .125$
	$\frac{9}{16} = .5625$	$\frac{9}{32} = .28125$	$\frac{9}{64} = .140625$
	$\frac{10}{16} = .625$	$\frac{10}{32} = .3125$	$\frac{10}{64} = .15625$
	$\frac{11}{16} = .6875$	$\frac{11}{32} = .34375$	$\frac{11}{64} = .171875$
	$\frac{12}{16} = .750$	$\frac{12}{32} = .375$	$\frac{12}{64} = .1875$
	$\frac{13}{16} = .8125$	$\frac{13}{32} = .40625$	$\frac{13}{64} = .203125$
	$\frac{14}{16} = .875$	$\frac{14}{32} = .4375$	$\frac{14}{64} = .21875$
		$\frac{15}{32} = .46875$	$\frac{15}{64} = .234375$

64ths

$\frac{1}{64} = .015625$	$\frac{17}{64} = .265625$	$\frac{33}{64} = .515625$	$\frac{49}{64} = .765625$
$\frac{2}{64} = .03125$	$\frac{18}{64} = .28125$	$\frac{34}{64} = .53125$	$\frac{50}{64} = .78125$
$\frac{3}{64} = .046875$	$\frac{19}{64} = .296875$	$\frac{35}{64} = .546875$	$\frac{51}{64} = .796875$
$\frac{4}{64} = .0625$	$\frac{20}{64} = .3125$	$\frac{36}{64} = .5625$	$\frac{52}{64} = .8125$
$\frac{5}{64} = .078125$	$\frac{21}{64} = .328125$	$\frac{37}{64} = .578125$	$\frac{53}{64} = .828125$
$\frac{6}{64} = .09375$	$\frac{22}{64} = .34375$	$\frac{38}{64} = .59375$	$\frac{54}{64} = .84375$
$\frac{7}{64} = .109375$	$\frac{23}{64} = .359375$	$\frac{39}{64} = .609375$	$\frac{55}{64} = .859375$
$\frac{8}{64} = .125$	$\frac{24}{64} = .375$	$\frac{40}{64} = .625$	$\frac{56}{64} = .875$
$\frac{9}{64} = .140625$	$\frac{25}{64} = .390625$	$\frac{41}{64} = .640625$	$\frac{57}{64} = .890625$
$\frac{10}{64} = .15625$	$\frac{26}{64} = .40625$	$\frac{42}{64} = .65625$	$\frac{58}{64} = .90625$
$\frac{11}{64} = .171875$	$\frac{27}{64} = .421875$	$\frac{43}{64} = .671875$	$\frac{59}{64} = .921875$
$\frac{12}{64} = .1875$	$\frac{28}{64} = .4375$	$\frac{44}{64} = .6875$	$\frac{60}{64} = .9375$
$\frac{13}{64} = .203125$	$\frac{29}{64} = .453125$	$\frac{45}{64} = .703125$	$\frac{61}{64} = .953125$
$\frac{14}{64} = .21875$	$\frac{30}{64} = .46875$	$\frac{46}{64} = .71875$	$\frac{62}{64} = .96875$
$\frac{15}{64} = .234375$	$\frac{31}{64} = .484375$	$\frac{47}{64} = .734375$	

TABLE OF METRIC LINEAR MEASURE

- 10 Millimeters = 1 Centimeter
- 10 Centimeters = 1 Decimeter
- 10 Decimeters = 1 Meter
- 1 Centimeter = .3937 inch
- 1 Decimeter = 3.937 inches
- 1 Meter = 39.37 inches

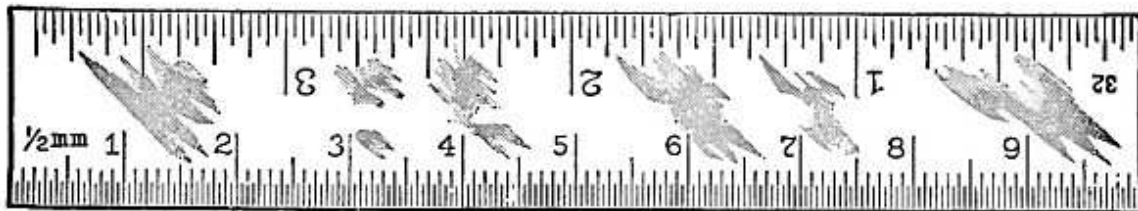

METRIC AND ENGLISH LINEAR MEASURE

The measuring rule herewith is graduated, one edge in the Metric system and the other edge in the English system. This shows at a glance the comparison of the fractions of the Metric and English units, the meter and the inch.

Equivalents of Millimeters in Decimals of Inches

$\frac{1}{16}$ mm = .00394"	8 mm = .31496"	18 mm = .70866"
$\frac{1}{8}$ mm = .00787"	9 mm = .35433"	19 mm = .74803"
$\frac{1}{4}$ mm = .01969"	10 mm = .39370"	20 mm = .78740"
1 mm = .03937"	11 mm = .43307"	21 mm = .82677"
2 mm = .07874"	12 mm = .47244"	22 mm = .86614"
3 mm = .11811"	13 mm = .51181"	23 mm = .90551"
4 mm = .15748"	14 mm = .55118"	24 mm = .94488"
5 mm = .19685"	15 mm = .59055"	25 mm = .98425"
6 mm = .23622"	16 mm = .62992"	26 mm = 1.02362"
7 mm = .27559"	17 mm = .66929"	



DOUBLE BACK GEAR HEAD

The illustration shows the double back geared head stock with gear guards removed. The double back gear, it will be seen, is only an intermediate gear drive of intermediate power between the single back gear and the direct cone drive. In other words the single back gearing develops low speed and greatest power. The double back gear, which is the intermediate set of gears, develops intermediate speed and intermediate power. The direct cone drive develops high speed and minimum power.

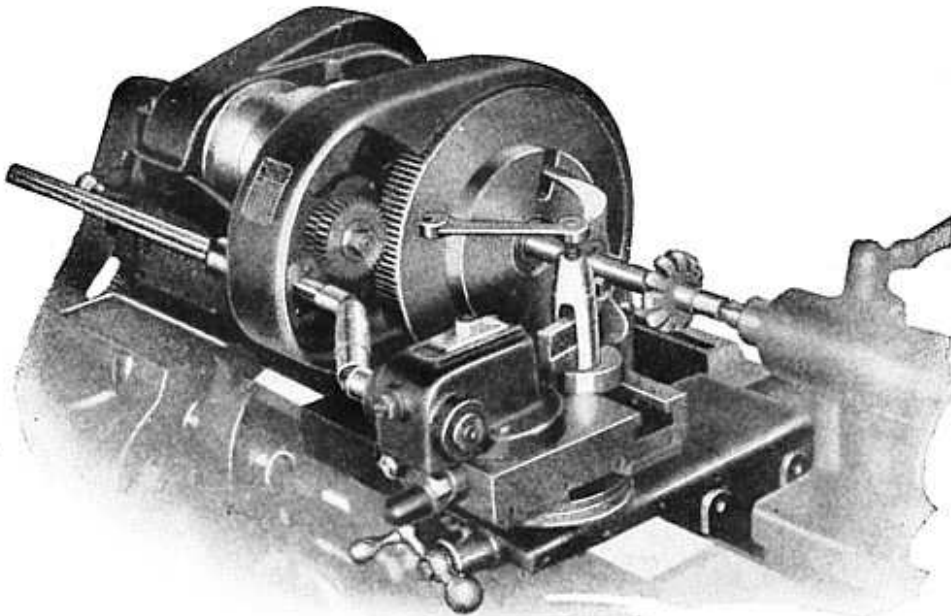

RELIEVING OR BACKING OFF ATTACHMENT FOR THE LATHE

Illustration above shows a relieving or backing off attachment that is attached to the head spindle of a lathe. The attachment is used for the backing off of cutters, taps, etc. It requires very little time to attach to the lathe, and when the required tools are relieved or backed off the attachment can be removed.

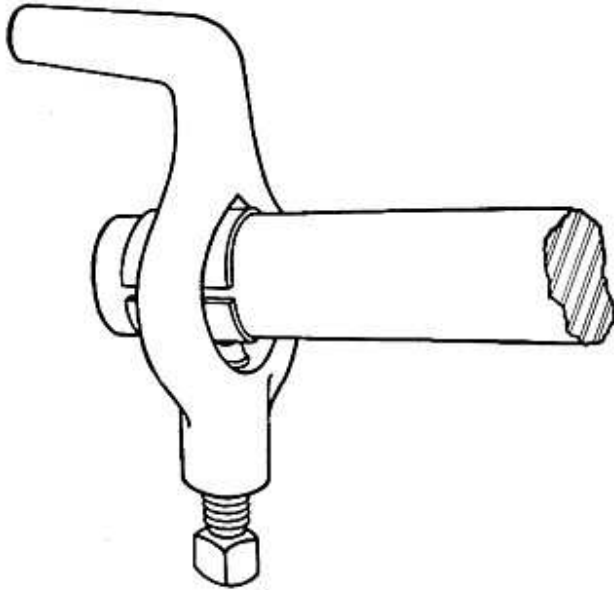

Fig. 644

Fig. 644.—The use of a piece of sheet brass to protect the finished surface from the dog set screw.

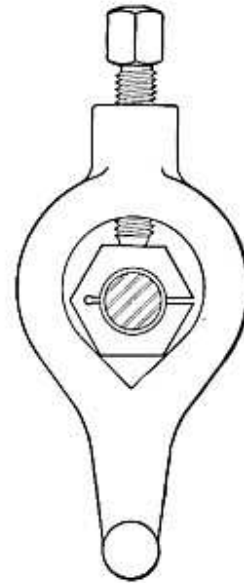

Fig. 645

Fig. 645.—A common nut cut by a hack-saw and clamped by a dog for driving work that has been threaded on one end.

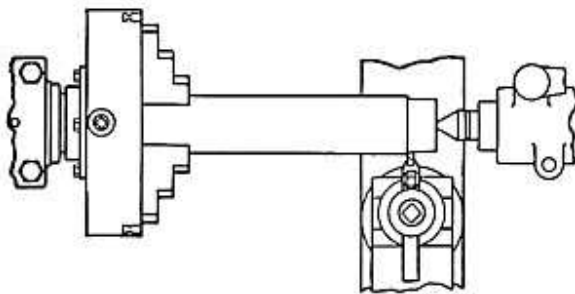

Fig. 646

Fig. 646.—Machining work, one end of which is held and driven by the lathe chuck, the other end on the tail center of the lathe.

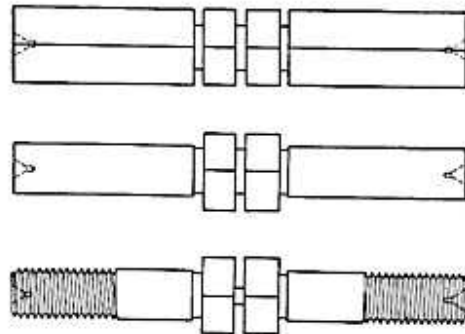

Fig. 647

Fig. 647 shows method of machining bolts or screws in pairs. When many pieces of one kind are required, machining in pairs increases production and reduces the cost.

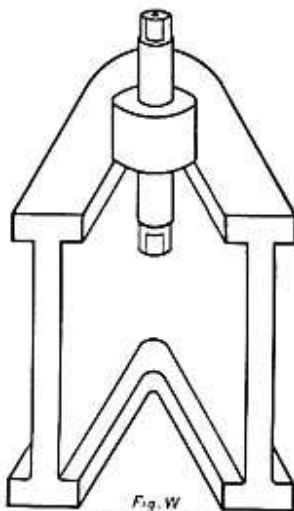

Fig. 648

Fig. 648 is a small cast iron anvil that is handy around the machine shop.

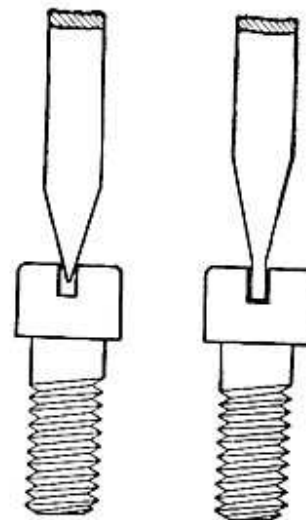

Fig. 649

Fig. 649 shows the proper finish for a screw driver bit in the slot of the screw.

South Bend Machine Shop Course

For Machinist Apprentices

The South Bend Machine Shop Course consists of 52 practical projects covering the fundamental operations of modern machine shop practice. The Course is based on production methods used in the building of machinery in industry. Job Sheets and Blue Prints have been worked out and are furnished for each Project. A Text-Book is used in conjunction with the course.

COPIES OF DRAWINGS AND JOB SHEETS

Shop Instructors desiring to duplicate the Blue Prints or Job Sheets may do so. Additional copies prove valuable for lecture work, with them the Instructor is able to impart information to the class instead of to the individual.

ROUGH CASTINGS FOR PROJECTS

If you are unable to obtain castings for projects in your locality we can supply them at the prices shown in Bulletin No. 55. If you are not equipped for doing planer work on projects we can do it for you charging only the actual expense incurred.

52 PRACTICAL PROJECTS

The 52 Projects in the Course cover a wide range of machine shop work starting with simple elementary jobs and gradually advancing so that the more advanced projects require skill equal to that of the expert mechanic.

We list below a few of the 52 projects:

<p>No. 13. 1" Bolt and Nut 39. Small Bench Vise 44. Jack Screw, heavy duty 29. Boring Bar for the Lathe 7. Drill Chuck Arbor 10. Blacksmith Drill Chuck 20. Machinist's Clamp</p>	<p>No. 6. 60 degree Lathe Centers 68. 8" Bench Lathe for Wood Turning 70. ¼ H.P. Gasoline Engine 31. Morse Taper Standard Test Plug 56. Draw-in Chuck Attachment 66. 8-inch Emery Grinder</p>
---	---

Educators in foreign countries as well as those in the United States have shown much interest in this Machine Shop Course. At the present time there are over 3000 schools and shops using the course.



BULLETIN NO. 55

The South Bend Machine Shop Course

This 16-page Bulletin gives complete detailed information on the South Bend Machine Shop Course and prices of the Projects, Rough Castings, Steel and Hardware parts. The Booklet will be mailed post-paid, no charge, to any supervisor, professor or instructor on request.

South Bend Machine Shop Course

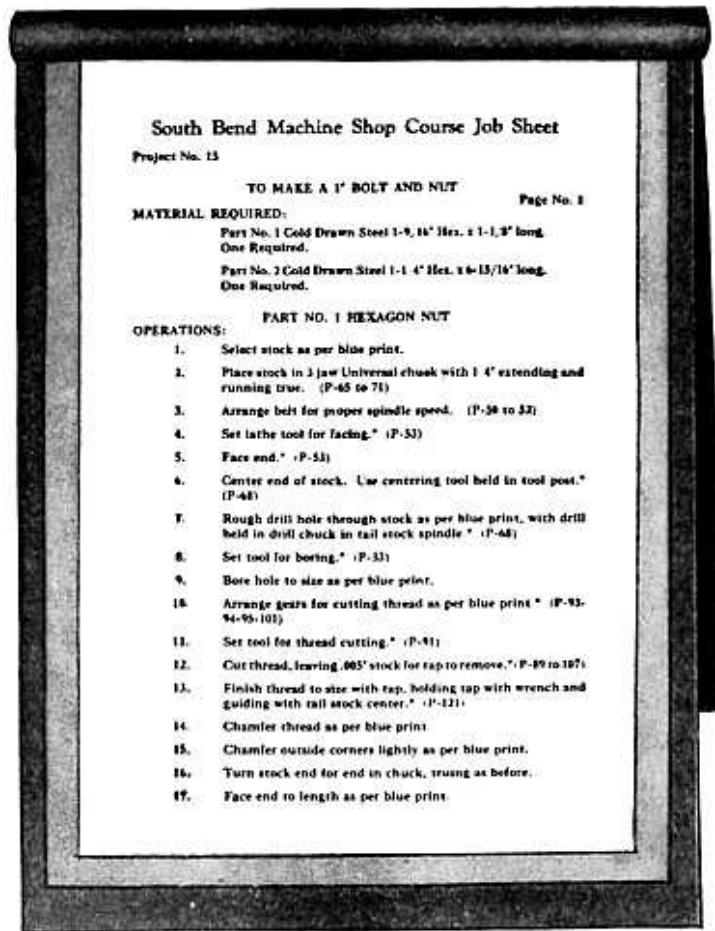

SAMPLE JOB SHEET (Actual Size 8 1/2" x 14") FOR PROJECTS

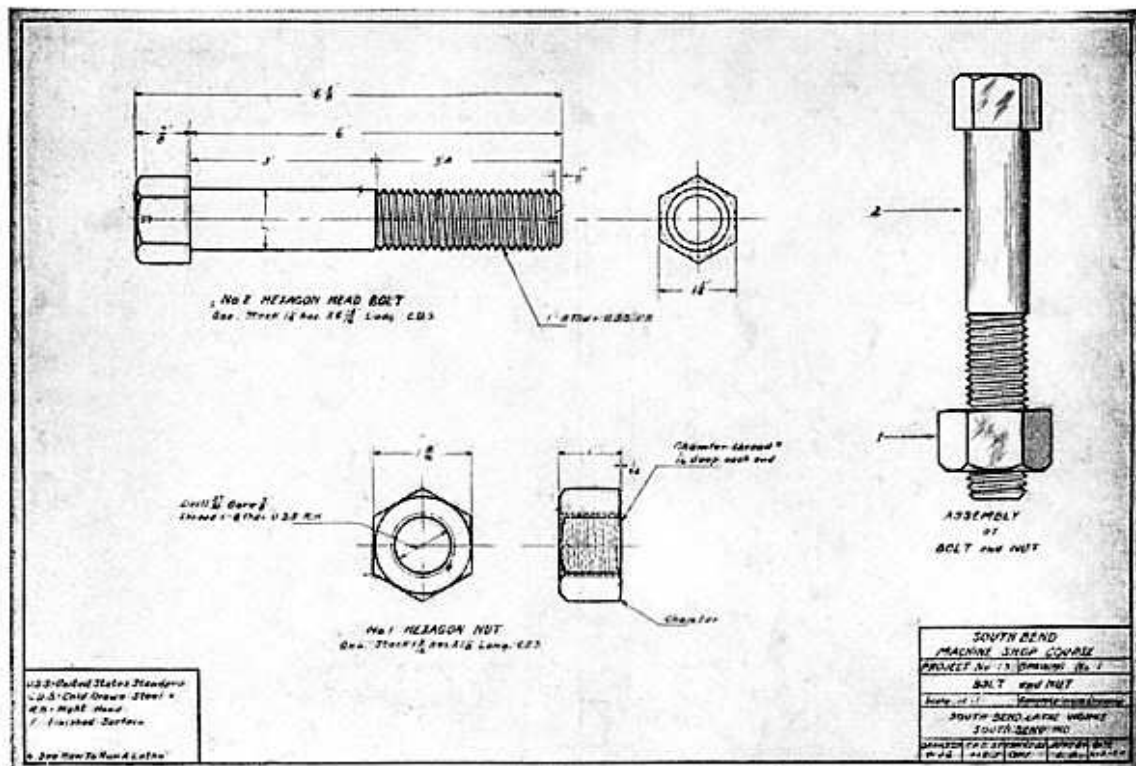

SAMPLE BLUE PRINT (Actual Size 12" x 18") FOR PROJECTS

INFORMATION ON GEARS

Diameter, when applied to gears, is always understood to mean the pitch diameter.

Diametral Pitch is the number of teeth to each inch of the pitch diameter.

Example: If a gear has 40 teeth and the pitch diameter is 4 inches, there are 10 teeth to each inch of the pitch diameter and the diametral pitch is 10, or in other words, the gear is 10 diametral pitch.

Number of Teeth required, pitch diameter and diametral pitch given. Multiply the pitch diameter by the diametral pitch.

Example: If the diameter of the pitch circle is 10 inches and the diametral pitch is 4, multiply 10 by 4 and the product, 40, will be the number of teeth in the gear.

Number of Teeth required, outside diameter and diametral pitch given. Multiply the outside diameter by the diametral pitch and subtract 2.

Example: If the whole diameter is $10\frac{1}{2}$ and the diametral pitch is 4, multiply $10\frac{1}{2}$ by 4 and the product, 42, less 2, or 40, is the number of teeth.

Pitch Diameter required, number of teeth and diametral pitch given. Divide the number of teeth by the diametral pitch.

Example: If the number of teeth is 40 and the diametral pitch is 4, divide 40 by 4, and the quotient, 10, is the pitch diameter.

Outside Diameter or size of gear blank required, number of teeth and diametral pitch given. Add 2 to the number of teeth and divide by the diametral pitch.

Example: If the number of teeth is 40 and the diametral pitch is 4, add 2 to the 40, making 42, and divide by 4; the quotient, $10\frac{1}{2}$, is the whole diameter of gear or blank.

Distance Between Centers of two gears required. Add the number of teeth together and divide one-half the sum by the diametral pitch.

Example: If the two gears have 50 and 30 teeth respectively, and are 5 pitch, add 50 and 30, making 80, divide by 2, and then divide the quotient, 40, by the diametral pitch, 5, and the result, 8 inches, is the center distance.

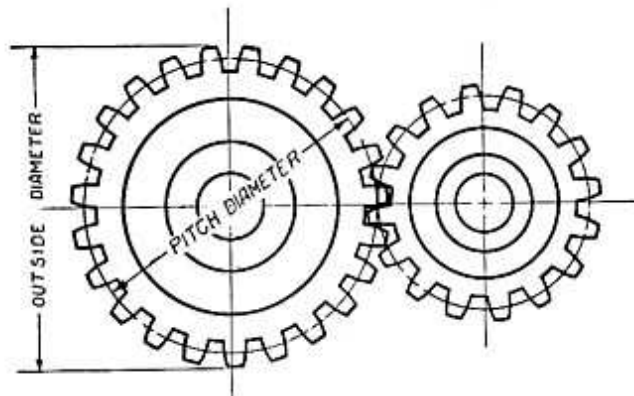

DON'TS FOR MACHINISTS**From "Machinery"**

- Don't run a lathe with the belt too loose.
- Don't run the point of your lathe tool into the mandrel.
- Don't rap the chips out of your file on the lathe shears.
- Don't set a lathe tool below the center for external work.
- Don't start up a lathe without seeing that the tail stock spindle is locked.
- Don't put an arbor or shaft on lathe centers without lubricant on them.
- Don't leave too much stock on a piece of work to take off with the finishing cut.
- Don't try a steel gauge or an expensive caliper on a shaft while it is running.
- Don't put a mandrel into a newly bored hole without a lubricant of some kind on it.
- Don't put a piece of work on centers unless you know that the internal centers are clean.
- Don't try to straighten a shaft on lathe centers, and expect that the centers will run true afterwards.
- Don't put a piece of work on lathe centers unless you know that all your centers are at the same angles.
- Don't take a lathe center out of its socket without having a witness mark on it, and put it back again according to the mark.
- Don't start polishing a shaft on lathe centers without having it loose enough to allow for the expansion by heat from the polishing process.
- Don't run your lathe tool into the faceplate.
- Don't try to knurl a piece of work without oiling it.
- Don't run a lathe an instant after the center begins to squeal.
- Don't forget to oil your machine every morning; it works better.
- Don't forget that a fairly good center-punch may be made from a piece of round file.
- Don't forget that a surface polished with oil will keep clean much longer than one polished dry.
- Don't start to turn up a job on lathe centers unless you know that the centers are both in line with the ways.
- Don't cross your belt laces on the side next the pulley, for that makes them cut themselves in two.
- Don't try to cut threads on steel or wrought iron dry; use lard oil or a cutting compound.
- Don't run a chuck or faceplate up to the shoulder suddenly; it strains the spindle and threads and makes removal difficult.
- Don't screw a tool post screw any tighter than is absolutely necessary; many mechanics have a false idea as to how tight a lathe tool should be to do its work.
- To drive the center out of head spindle use a rod and drive through the hole in spindle.
- When putting a lathe chuck on the head spindle, always remove the center.
- When the center is removed from the head spindle of the lathe, always put a piece of rag in spindle hole to prevent any dirt from collecting.

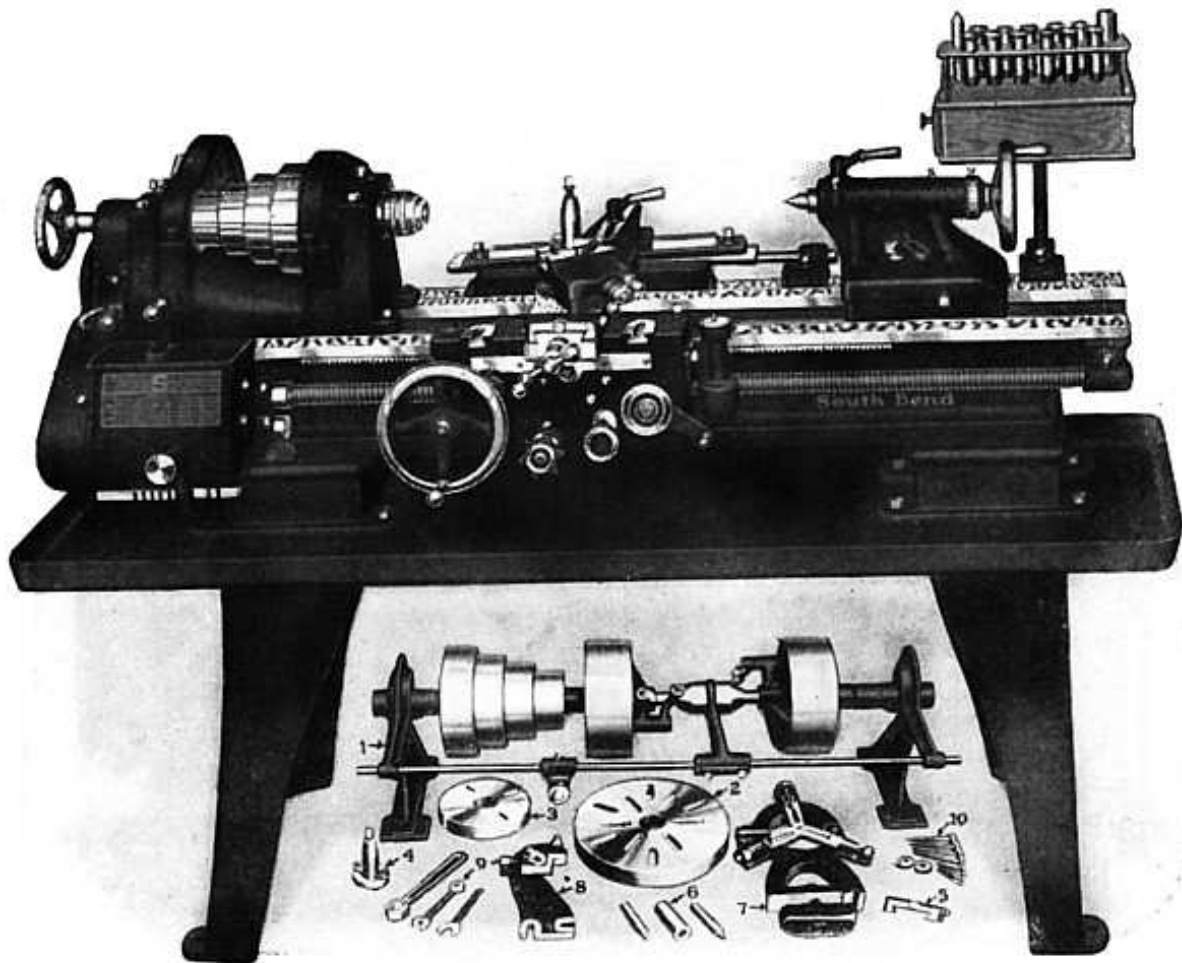

THE TOOL ROOM PRECISION LATHE

The tool room precision lathe, as its name implies, is used in the tool rooms of industrial plants for making fine tools, test and thread gauges, fixtures, etc., used in the making and testing of their manufactured products.

The tool room precision lathe is the modern back geared quick change screw cutting lathe with the addition of such equipment as draw-in collet chuck attachment, taper attachment, thread dial, micrometer stop, etc., and generally an oil pan.

Usually there are four sizes of tool room precision lathes—11"x4', 13"x5', 15"x6', and 16"x6'—countershaft drive or motor drive.

Being a tool room precision lathe does not mean these lathes are not also often used for other work of more general nature. However, in many plants, tool room lathes are used exclusively for fine, accurate tool work. Some tool room lathes are grouped ten, twenty, or thirty to one room, varying of course, according to the size of the plant.

The belt driven spindle cone type of lathe is more popular and considered to be the most practical type of driving power for a tool room lathe. This is because a belt drive transmits no vibration to the spindle. Therefore work produced on a lathe having a belt driven

Description Continued on Following Page

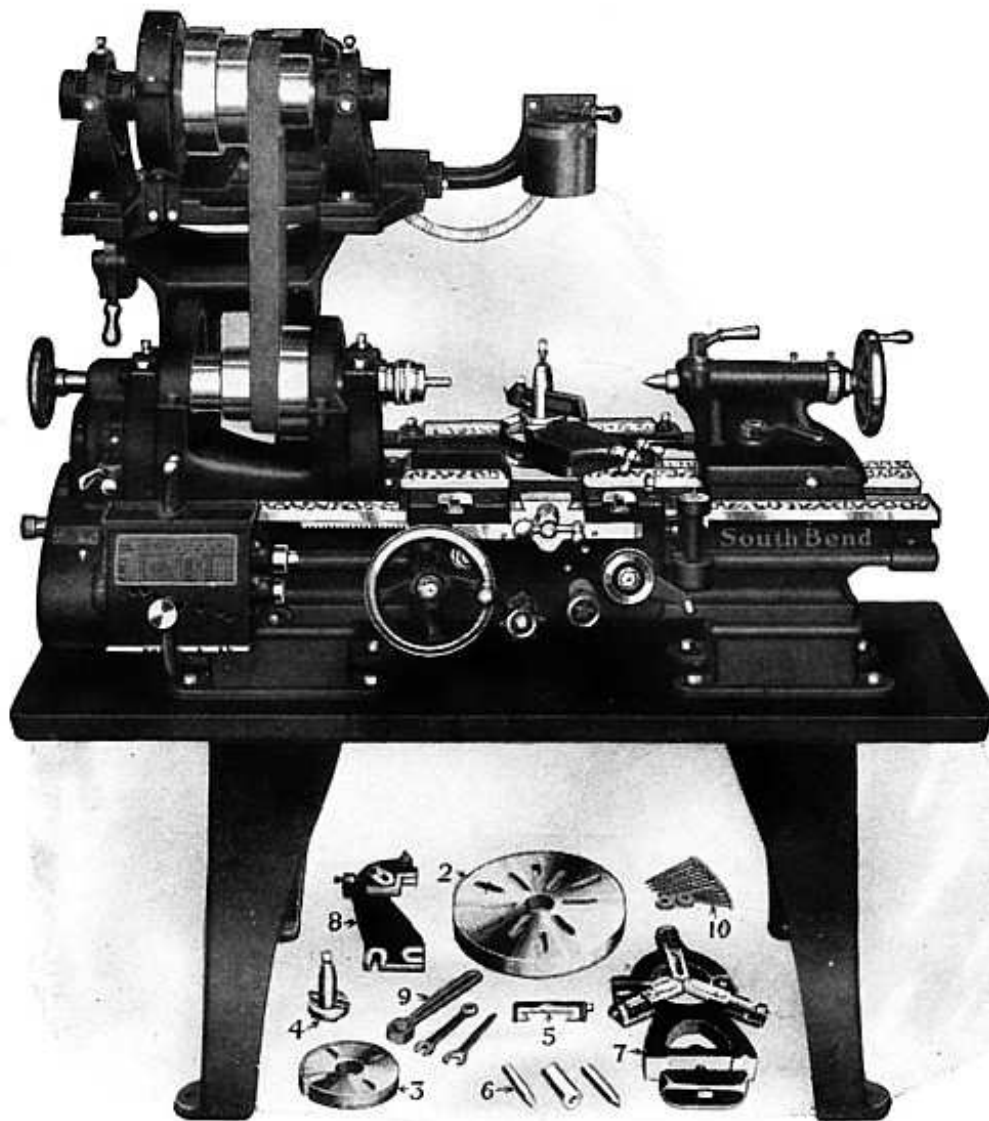

TOOL ROOM PRECISION LATHE WITH SILENT CHAIN MOTOR DRIVE

Description Continued from Page 126

spindle has an extra fine, smooth finish and more accurate surface, so absolutely necessary when taking a finishing cut on master taps, screw and plug gauges, etc.

The new model silent chain motor driven tool room precision lathe, shown above, while deriving its original driving power from a motor unit, has a belt drive between the countershaft and spindle cone. The motor drives the countershaft by a silent chain which eliminates all vibration. For a detailed description of the new model silent chain motor driven lathe, see pages 130 and 131.

Most skilled mechanics, selecting a tool room precision lathe, prefer the smaller lathe of medium weight, rather than the large, heavy type of lathe. Because tool room work is delicate, requiring the utmost accuracy, and at the same time speed in production of work, there usually are as many 11" and 13" lathes in the tool rooms of modern industrial plants as there are 15" and 16" sizes.

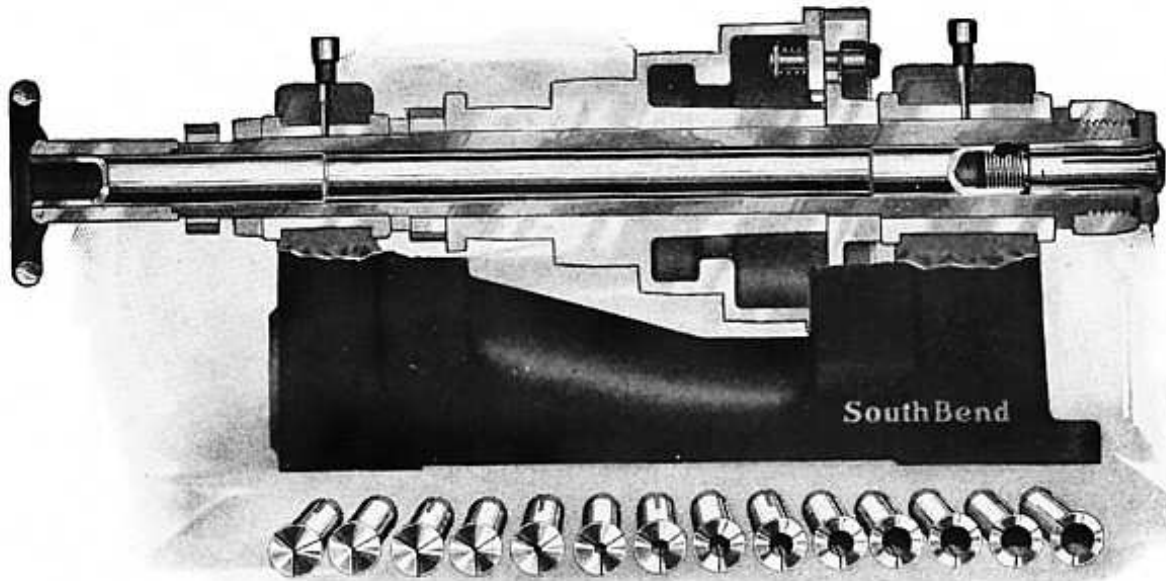

DRAW-IN COLLET CHUCK ATTACHMENT ON THE LATHE

The halftone shows a cross section of the headstock of the lathe in order to show the application of the Draw-in Collet Chuck Attachment. Note the Collets above with various hole sizes.

The Draw-in Collet Chuck Attachment consists of: a split collet chuck, hardened, ground inside and outside; a taper sleeve into which the collet chuck fits, which in turn is fitted to the taper of the lathe spindle; a hand wheel and the hollow draw-bar which enters the spindle from the rear end and screws on the thread of the collet chuck, to tighten or release the work; and a knock-off nut which screws on the spindle nose and is used to remove the taper sleeve and collet.

The Collet Chuck Attachment is used in industry for the production of small metal parts and in the tool room for fine accurate work. Either long or short pieces of material may be held in the chuck for machining.

The Hand Wheel type Draw-in Collet Chuck Attachment is practical for tool work. The Hand Lever type can be operated without stopping lathe spindle.

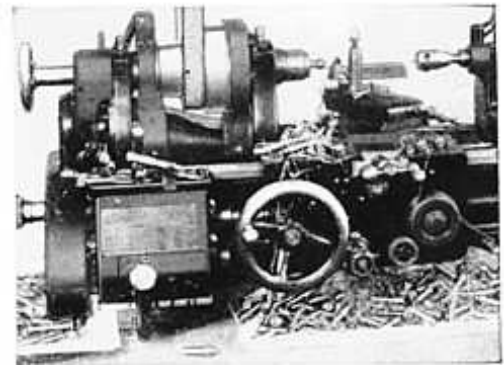

Collets used are steel, hardened and ground inside and outside, furnished from $\frac{1}{16}$ " up to $1\frac{3}{8}$ " in sixty-fourths.

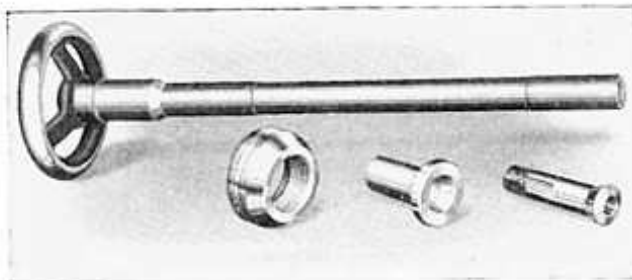

The Hand Wheel Draw-in Collet Chuck Attachment

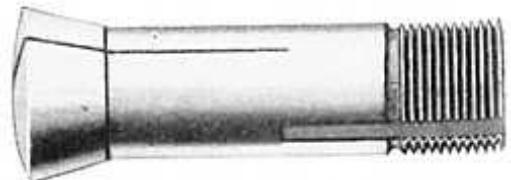

The Collet

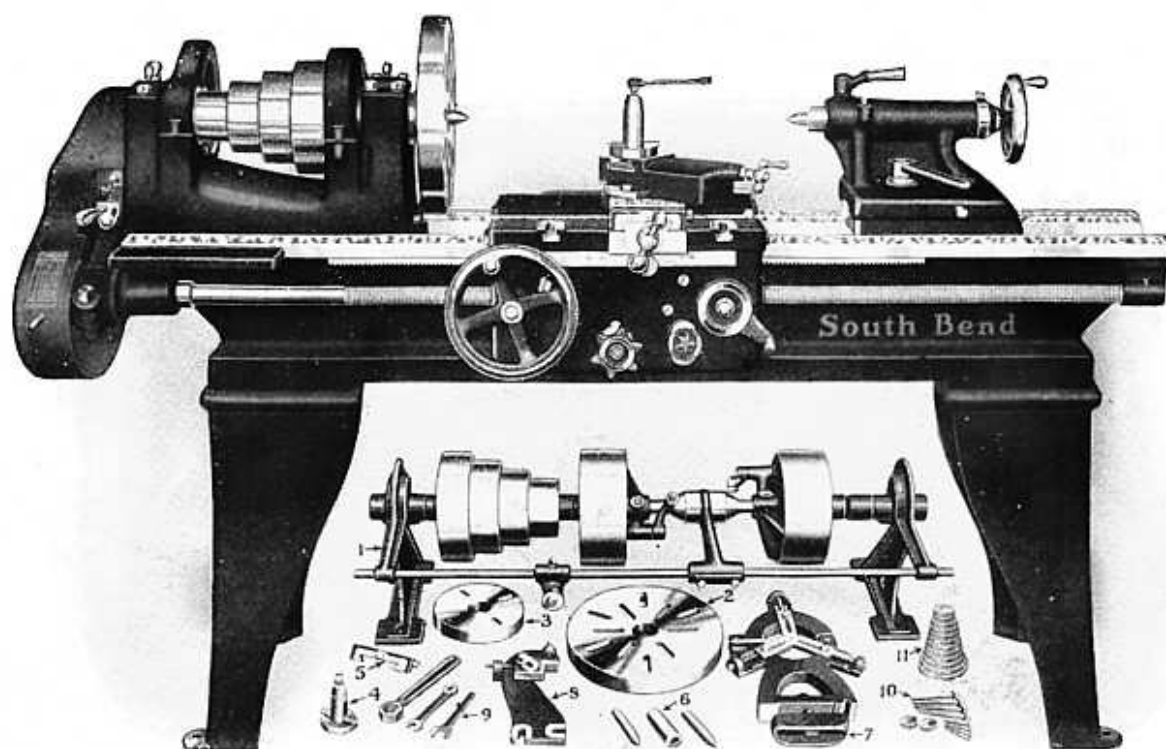

THE NEW MODEL BACK GEARED STANDARD CHANGE SCREW CUTTING LATHE WITH OVERHEAD COUNTERSHAFT DRIVE

The back geared standard change screw cutting lathe is widely used on production work where the pitch of threads to be cut do not vary to much extent. Instead of the quick change gear box, a set of independent gears are provided to obtain the various number of automatic feeds and pitch of screw threads.

The independent change gears do not offer as wide a variety of automatic feeds and screw threads. Except for this feature, the back geared standard change screw cutting lathe is identical in all other features with the quick change gear lathe. The standard change gear lathe is just as finely built, accurate and dependable, and will accommodate all of the modern attachments used on the quick change gear type of lathe.

Standard change gear lathes are less expensive to buy than the quick change gear lathes.

The index plate attached to the standard change gear lathe shows a selection of the proper gears for cutting screw threads of different pitch.

Standard change gear lathes will cut all standard threads, right or left hand, from 2 to 40 threads per inch. Many other threads can be cut by compounding the proper gears.

The various automatic longitudinal and automatic cross feeds are obtained by changing the independent gears. Compounding the automatic feed gears will permit the addition of other feeds, both fine and coarse. A swinging guard permits easy access to these gears.

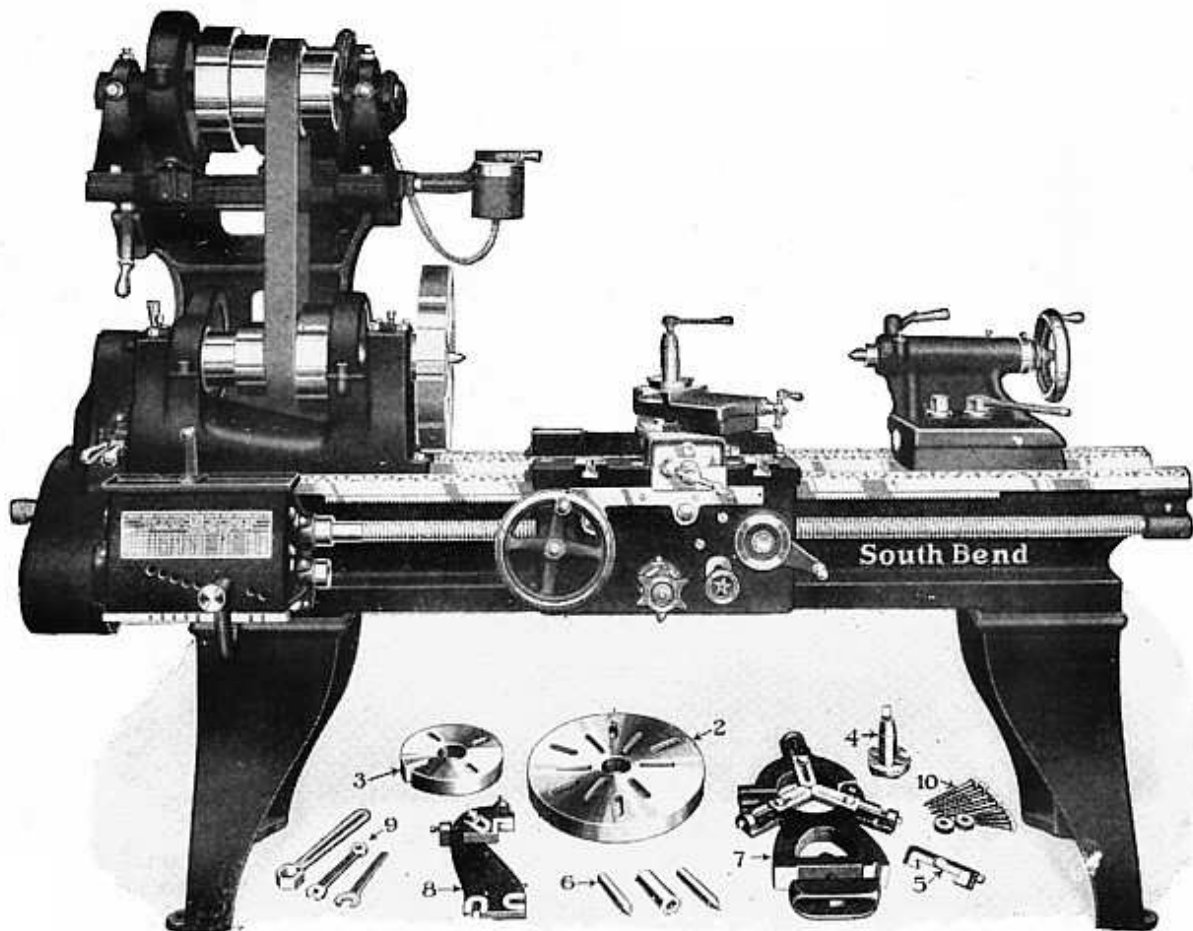

SILENT CHAIN MOTOR DRIVEN LATHE

The new model silent chain motor driven back geared quick change screw cutting lathe is practical, powerful and efficient. The motor drive unit, with its silent chain, eliminating vibration and noise, is the ideal electric drive for the screw cutting lathe.

The spindle is driven by belt from an overhead cone, which receives its power from the motor thru the silent chain. The absence of vibration means the cutting tool will always leave a smooth even surface, so necessary on precision tool work.

The constant speed reversing motor is necessary on account of the numerous start, stop and reverse operations in cutting screw threads. The motor is mounted above the lathe, away from all dirt and chips. A lever tilts table forward for easy, quick belt shifting. Stretch of the belt is taken up by an independent adjustment.

The Reversing Control (Drum Type) switch, has proven the most practical type for lathe work. Located in front of the lathe within easy reaching distance of the operator, it has a rotary motion of three positions—Left, for forward speeds; Center, for neutral, and right, for reverse.

The motor driven lathe is widely used in shops where space is limited because no overhead installation equipment is required—a hook-up with the electric current makes it ready for operation. A 9-inch lathe of this type can be safely operated from any ordinary light socket.

The simplicity of its construction makes the silent chain motor drive unit inexpensive in cost and economical to operate. The General Electric and Westinghouse Electric companies use silent chain motor driven lathes extensively.

INFORMATION ON MOTOR DRIVEN LATHES

A Motor Driven Lathe is a lathe that has an electric motor mounted as a part of the lathe itself. This motor has a Reversing Control Switch of the drum type. The Control Lever has three positions—Left, for Forward Speeds; Right, for Reverse Speeds, and Center, for Neutral.

When installing a motor driven lathe the reversing motor should always conform to the electric current of the locality. Exact current specifications are therefore necessary when ordering. These specifications can be secured from the power company of the locality or taken from the electric meter measuring the power of the shop where the lathe will be set up. These specifications may be:

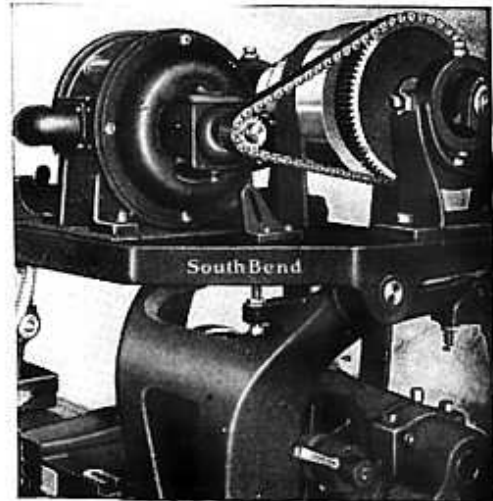

End View of Silent Chain Drive

company of the locality or taken from the electric meter measuring the power of the shop where the lathe will be set up. These specifications may be:

Alternating Current—of Single, Two or Three Phase, any Cycle and any Voltage.

Direct Current—of any Voltage.

ALTERNATING CURRENT

Single Phase Alternating Current is used extensively for lighting purposes. As a rule, ordinary electric light circuits are not of sufficiently heavy voltage to operate more than a One-Half H.P. Motor. Some cities will not permit more than a One-Quarter H.P. Motor to be operated from light circuits. Usually this is covered by a City Ordinance, which also outlines the code of all electric specifications. Larger motors can be operated on Single Phase current by installing special wiring which is safer, more economical, and durable.

DIRECT CURRENT

Direct Current is not widely used. However, there are some localities where it is the only available current. Any Direct Current Motor will operate from any Direct Current Line of the same Voltage Rating. In addition to the Control Switch furnished for Direct Current Motors, for reasons of safety, a special starting equipment is also required on all Direct Current motors of One H.P. or larger capacity. A simple resistance unit, designed to operate the Reversing Type motor, is sufficient for the operation of ordinary screw cutting lathes, and is furnished by motor manufacturers at slight additional cost.

When ordering electric motors for lathes, always state the exact specifications. When installing any motor driven lathe, always make sure the specifications are correspondingly correct. Specifications should definitely show one of the following:

Alternating Current—Phase, Cycle and Voltage.

Direct Current—Voltage only.

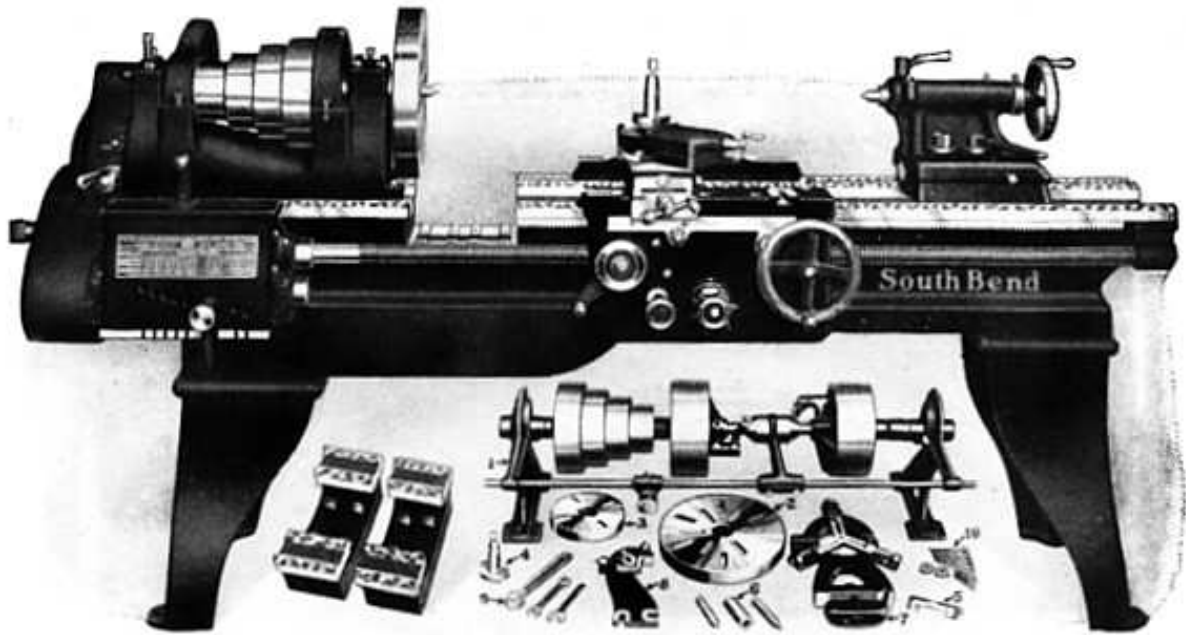

THE IMPROVED GAP LATHE WITH DOUBLE BRIDGE

The illustration shows the improved Gap Lathe with Double Bridge. This Lathe is used for machining work of large diameter. The Gap Lathe permits the swinging of work of large diameter over the gap, but does not increase the machining capacity of the lathe. For example it will swing a flywheel or a brake drum, and permit the hub of the fly wheel to be machined, and the brake drum of the automobile wheel, but will not permit machining of the fly wheel or the auto wheel on the outside diameter, if it is larger than the swing or capacity of the lathe.

On Gap Lathes the control mechanism of the apron is transposed so that the carriage can be fed by hand or power over the gap for machining narrow work. Refer to pages 20 and 129 for other features of this lathe as they are the same as found on the regular Quick Change and Standard Change Gear Lathes.

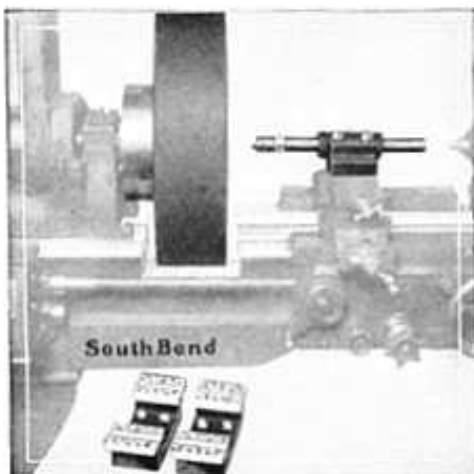

Double Bridge Removed from Gap for Extremely Wide Work

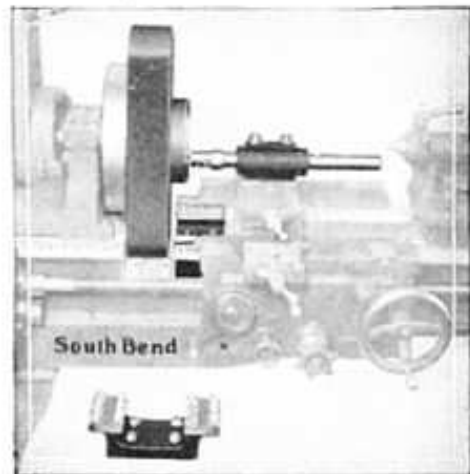

One Bridge Removed for Narrow Work, the Other Bridge Remains to Support Carriage

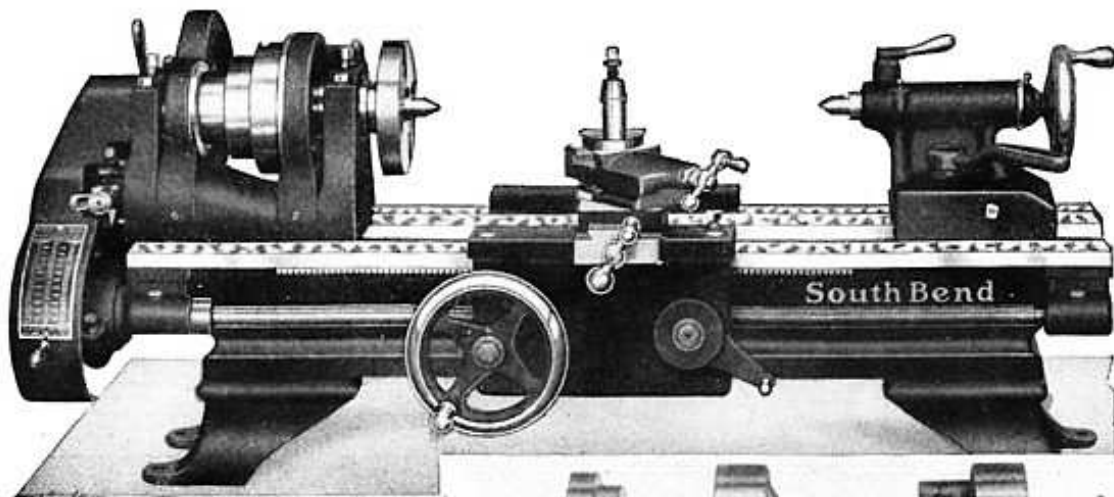

THE 9" JUNIOR BACK GEAR SCREW CUTTING BENCH LATHE

Overhead Countershaft Drive

The Bench Lathe is popular in the small shop and in the factory for large production of small parts.

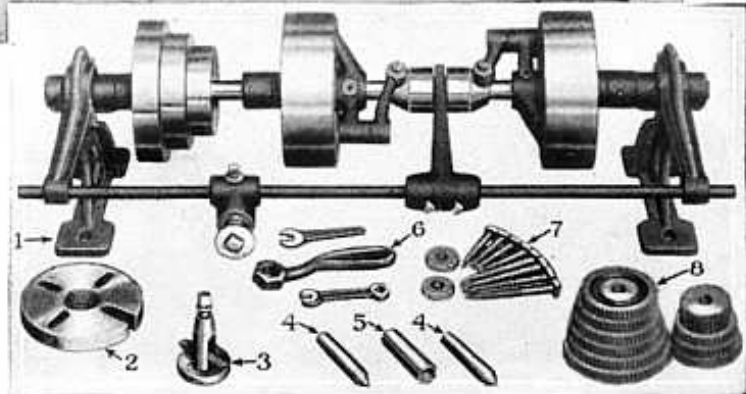

The illustration shows the 9" Junior Bench Lathe with the Countershaft and Equipment. The Junior Lathe is stripped of the automatic friction cross feed and friction longitudinal feed so as to bring the price within the reach of the small shop where these parts are not needed. The large face plate, center rest and follower rest have been omitted from the equipment.

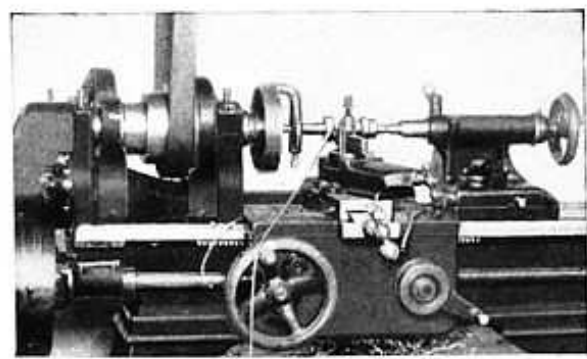
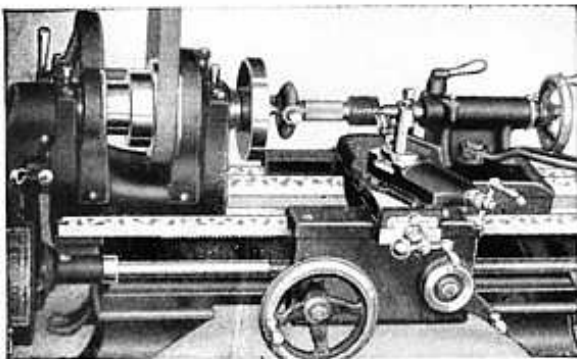

Bench Lathes in Use in a Manufacturing Plant

STANDARD AND QUICK CHANGE BENCH LATHES

Bench Lathes are also made in the 9", 11" and 13" sizes, Quick Change or Standard Change Gear Type. The Bench Lathe is exactly like the floor leg Lathe in every respect except that bench legs have been substituted in place of floor legs.

In addition to the countershaft type of drive Bench Lathes may be driven by the Simplex Motor Drive and the Self-Contained Unit Motor Drive, described on the following pages.

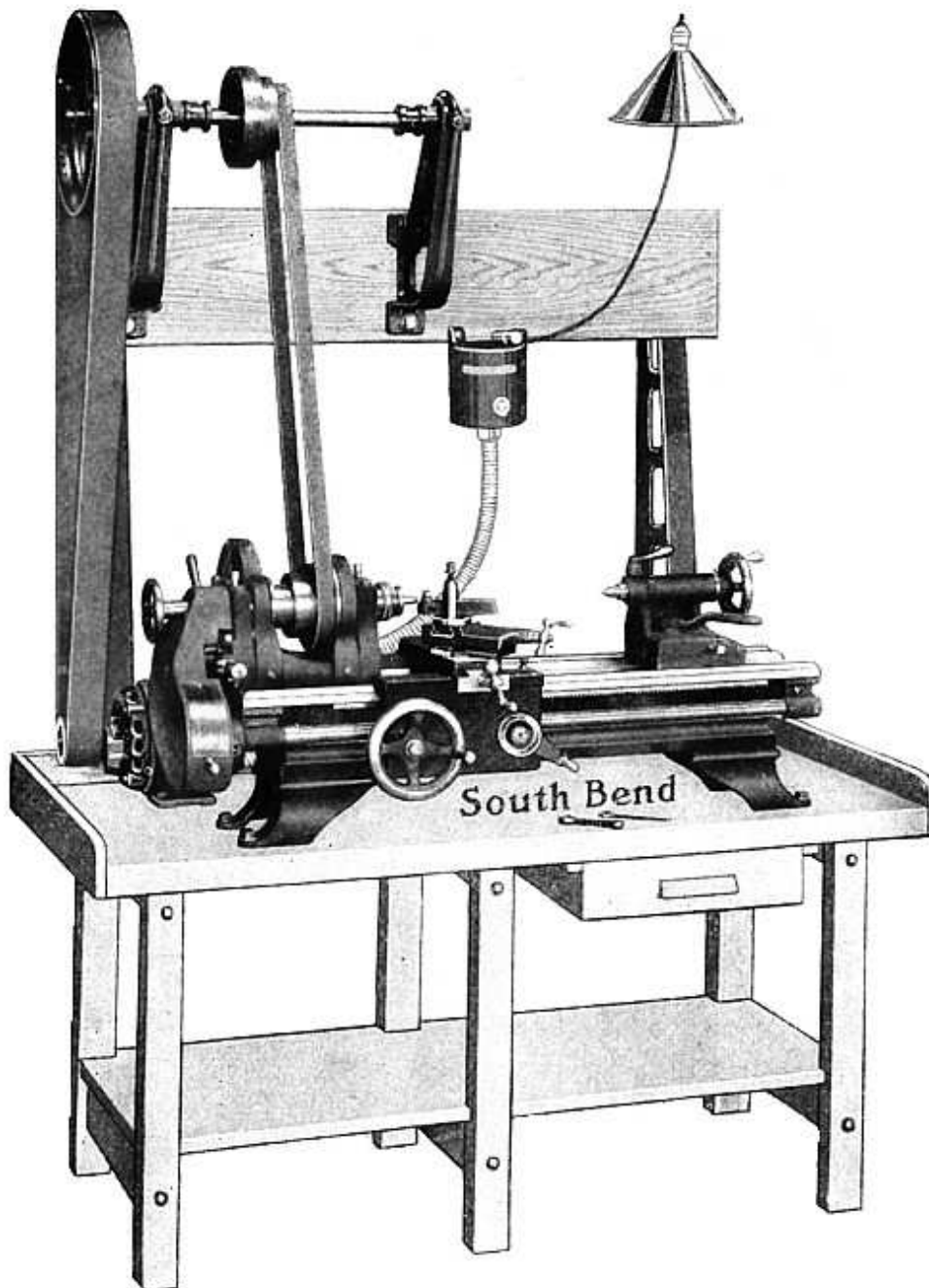

SIMPLEX MOTOR DRIVE FOR BENCH LATHES

Wall Type Simplex Countershaft Used

The illustration shows the Simplex Motor Drive method for the operation of Bench Lathes. A $\frac{1}{4}$ H.P. Reversing Motor operated from light socket, rests on the bench behind the Lathe and drives the countershaft which is supported above the Lathe by special countershaft standards bolted to the bench. A Reversing Switch (drum type) conveniently located within easy reach of the operator, controls the operation of the Lathe for starting, stopping and reversing the head spindle.

The Motor should be of the reversing type having a constant speed, 1,200 R.P.M. Either A. C. or D. C. Motors may be used.

The Simplex Motor Drive method can be applied to 9", 11" and 13" Quick Change Gear or Standard Change Gear Bench Lathes and is practical and efficient for the lathe used for doing small accurate work.

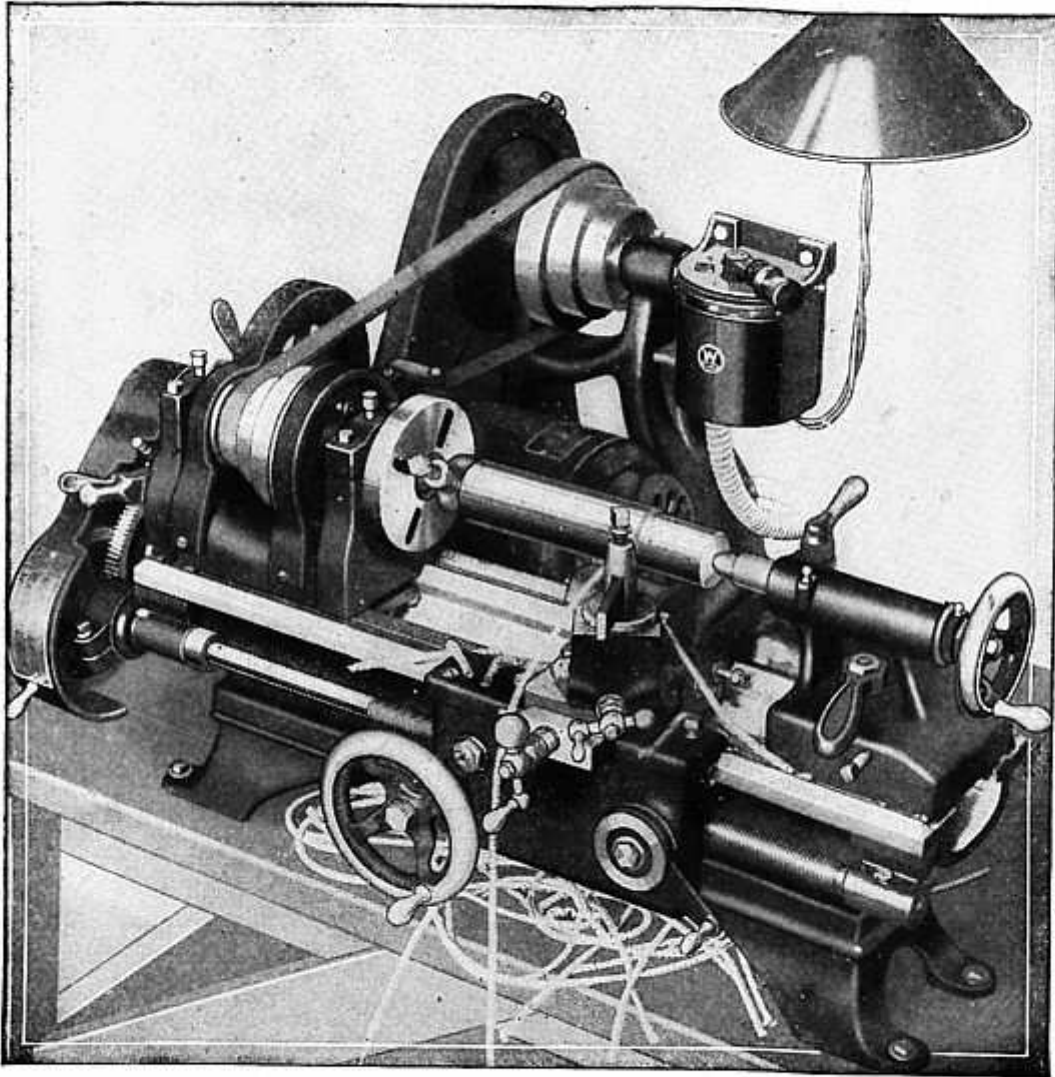

THE SELF-CONTAINED MOTOR DRIVE FOR BENCH LATHES

The Self-Contained Motor Drive for Bench Lathes is shown above applied to a 9" Bench Lathe. The Motor Drive Unit is mounted directly behind the lathe on the bench and when connected to the current it is ready for operation. It is a practical drive for the 9", 11" and 13" Quick Change Gear and Standard Change Gear Bench Lathes.

A Reversing Motor either A. C. or D. C. having a constant speed of 1200 R.P.M. rests on the special base and drives the counter-shaft cone through a chain and sprocket which gives a noiseless, efficient drive for a screw cutting lathe. The Spindle Cone of the lathe is driven by a leather belt.

The Reversing Switch (drum type) is conveniently located so that the operator can start, stop or reverse the Motor from an easy working position in front of the Lathe.

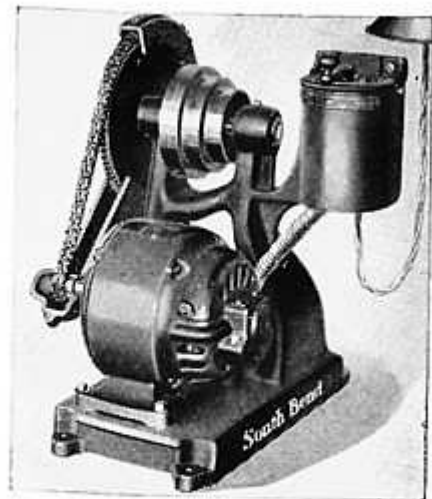

End View of Self-Contained Motor Drive Unit

ERECTION PLAN FOR BENCH LATHES

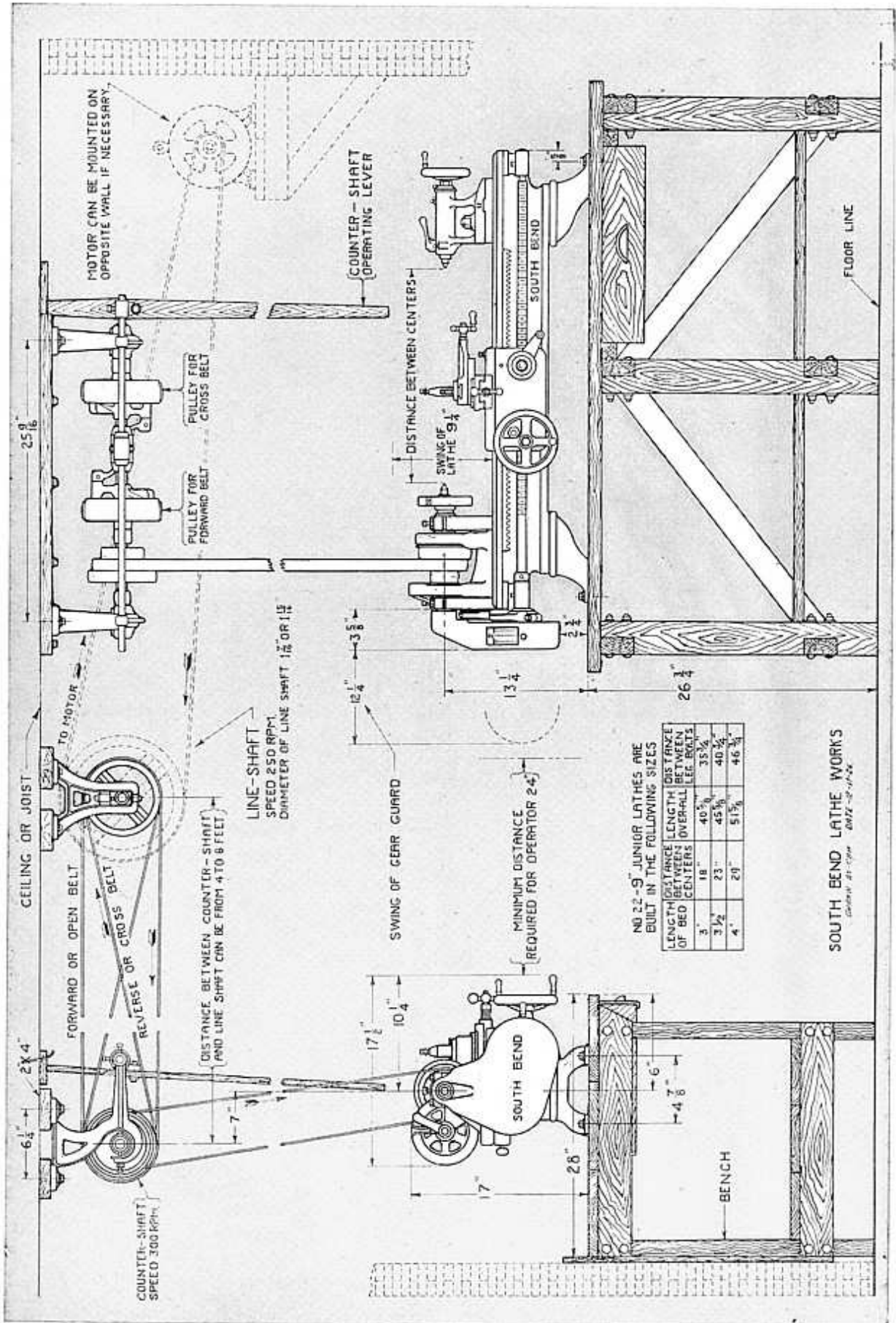

FOUNDATION PLAN FOR LATHES

Plan No. 16.
for 9 to 12 Lathes

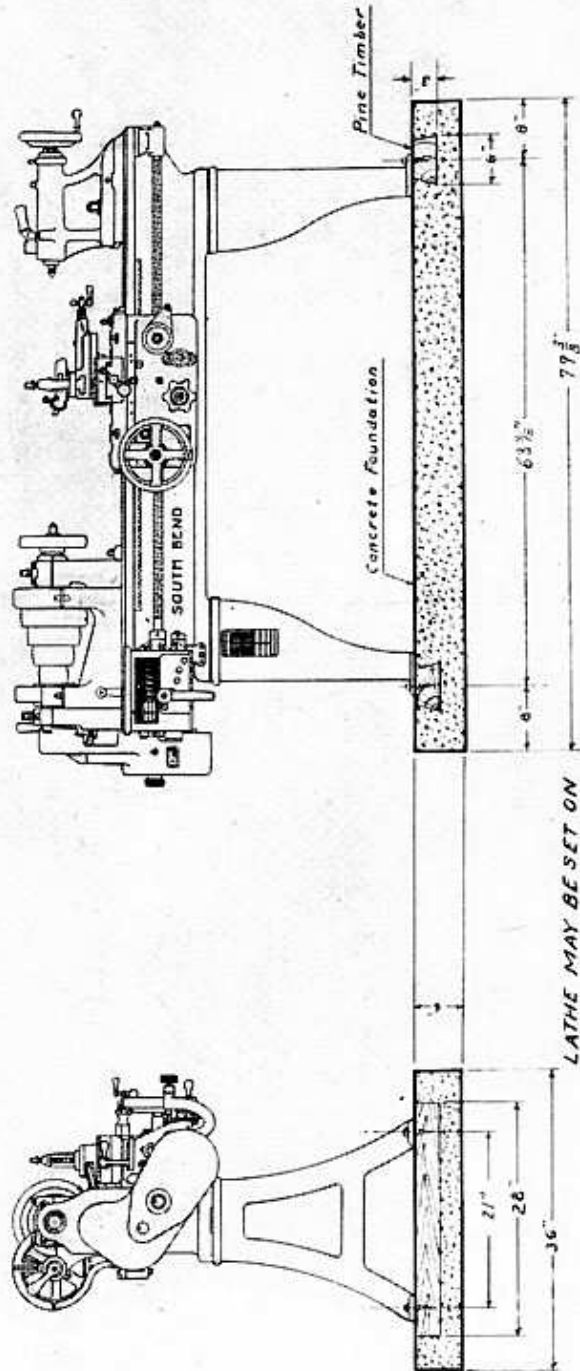
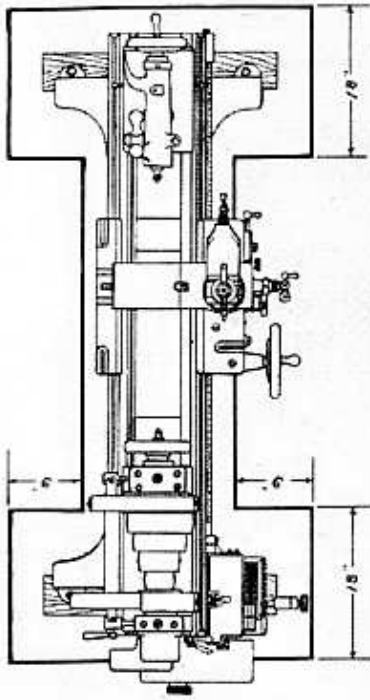

FOUNDATION PLAN
 FOR SOUTH BEND LATHE
 16" SWING 6' BED
 SOUTH BEND LATHE WORKS
 SOUTH BEND, IND.
 Drawn by -D.D.A. Traced by -D.D.A. Checked by -

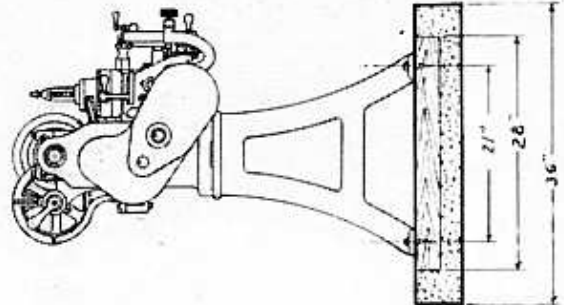

LATHE MAY BE SET ON
 CONCRETE FOUNDATION
 AS ILLUSTRATED OR ON
 SOLID WOOD FLOOR.



Size of Catalog 8½"x11", 72 Pages,
120 Illustrations

NEW LATHE CATALOG No. 88

Our New General Catalog No. 88 contains complete and up-to-date information on the entire line of South Bend New Model Back Gear Screw Cutting Lathes. Each size lathe is illustrated, described and priced in the various Countershaft and Motor Drive types. A complete line of Attachments, Tools, Chucks, and Accessories for the lathe is also shown and priced.

This valuable reference catalog will be mailed postpaid, free of charge, to Foremen or Supervisors, upon request. Include street number in address to insure safe delivery.

THE SMALL LATHE FOR PRODUCTION WORK

The Small Screw Cutting Lathe is used extensively in modern production work to excellent advantage, especially in plants manufacturing small articles in large quantities, such as typewriters, sewing machines, radio parts, telephones, electrical parts, etc.

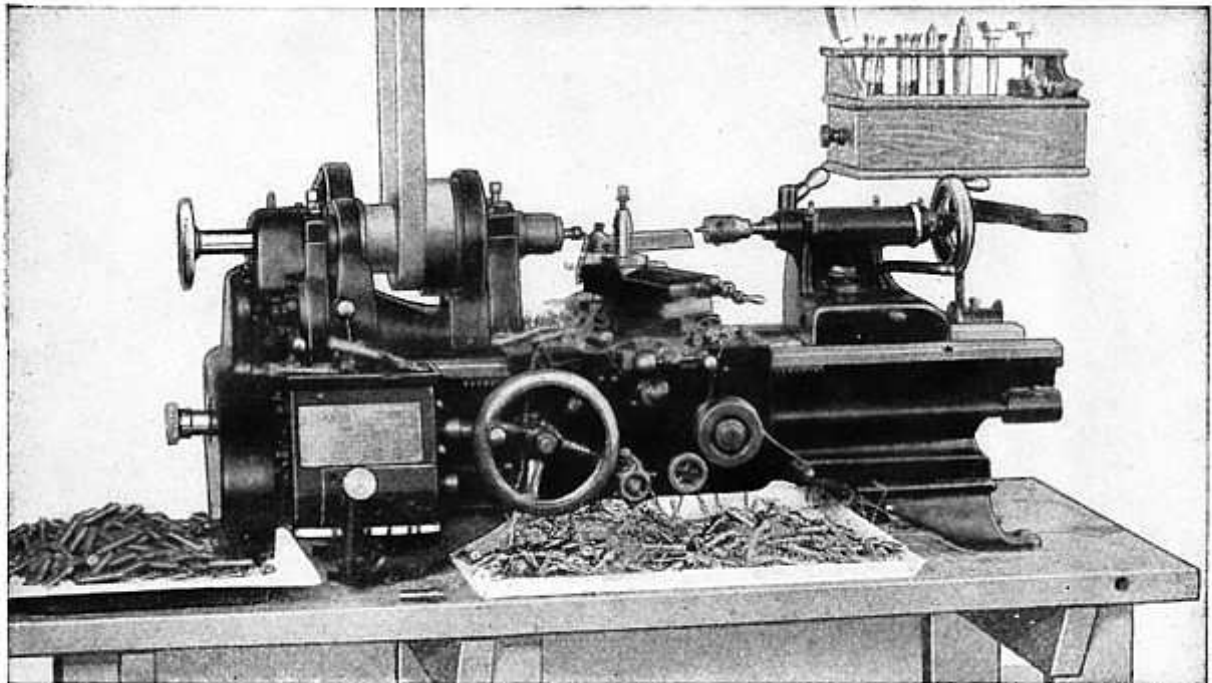

AN 11" SOUTH BEND BENCH LATHE IN USE
ON A MANUFACTURING JOB

The Bench Lathe shown above is equipped with a Draw-in Collet Chuck attachment. The operation is machining small steel studs where accuracy and precision is desired. A drill chuck is mounted in the tail spindle of the lathe and a forming and cutting off tool is mounted in the tool post. The lathe is driven by an overhead countershaft.

A LINE OF BACK GEAR SCREW CUTTING LATHES

A few of the Principal Specifications covering 210 sizes and types of South Bend Quick Change Gear and Standard Change Gear Lathes are shown below.

Swing Over Bed	Length of Bed	Distance Between Centers	Hole Thru Spindle	Swing Over Carriage	Width of Cone Belt	H.P. of Motor Required	Weight Crated Pounds
No. 22—9-inch Junior Lathes—Standard Change Gear							
9¼ in.	2½ ft.	11 in.	¾ in.	6⅞ in.	1 in.	¼	415
9¼ in.	3 ft.	18 in.	¾ in.	6⅞ in.	1 in.	¼	440
9¼ in.	3½ ft.	23 in.	¾ in.	6⅞ in.	1 in.	¼	465
9¼ in.	4 ft.	29 in.	¾ in.	6⅞ in.	1 in.	¼	490
9¼ in.	4½ ft.	26 in.	¾ in.	6⅞ in.	1 in.	¼	515
9-inch Lathes—Quick Change and Standard Change Gear							
9¼ in.	2½ ft.	11 in.	¾ in.	6⅞ in.	1 in.	¼	470
9¼ in.	3 ft.	18 in.	¾ in.	6⅞ in.	1 in.	¼	490
9¼ in.	3½ ft.	23 in.	¾ in.	6⅞ in.	1 in.	¼	510
9¼ in.	4 ft.	29 in.	¾ in.	6⅞ in.	1 in.	¼	530
9¼ in.	4½ ft.	36 in.	¾ in.	6⅞ in.	1 in.	¼	550
11-inch Lathes—Quick Change and Standard Change Gear							
11¼ in.	3 ft.	12 in.	⅞ in.	7⅞ in.	1½ in.	½	675
11¼ in.	3½ ft.	18 in.	⅞ in.	7⅞ in.	1½ in.	½	700
11¼ in.	4 ft.	24 in.	⅞ in.	7⅞ in.	1½ in.	½	725
11¼ in.	5 ft.	36 in.	⅞ in.	7⅞ in.	1½ in.	½	805
11¼ in.	5½ ft.	42 in.	⅞ in.	7⅞ in.	1½ in.	½	845
13-inch Lathes—Quick Change and Standard Change Gear							
13¼ in.	4 ft.	16 in.	1 in.	9 in.	1¾ in.	¾	1060
13¼ in.	5 ft.	28 in.	1 in.	9 in.	1¾ in.	¾	1110
13¼ in.	6 ft.	40 in.	1 in.	9 in.	1¾ in.	¾	1160
13¼ in.	7 ft.	52 in.	1 in.	9 in.	1¾ in.	¾	1210
13¼ in.	8 ft.	64 in.	1 in.	9 in.	1¾ in.	¾	1260
15-inch Lathes—Quick Change and Standard Change Gear							
15¼ in.	5 ft.	24½ in.	1⅛ in.	10⅝ in.	2 in.	1	1475
15¼ in.	6 ft.	36½ in.	1⅛ in.	10⅝ in.	2 in.	1	1550
15¼ in.	7 ft.	48½ in.	1⅛ in.	10⅝ in.	2 in.	1	1625
15¼ in.	8 ft.	60½ in.	1⅛ in.	10⅝ in.	2 in.	1	1735
15¼ in.	10 ft.	84½ in.	1⅛ in.	10⅝ in.	2 in.	1	1900
16-inch Lathes—Quick Change and Standard Change Gear							
16¼ in.	6 ft.	34 in.	1⅜ in.	11⅞ in.	2¼ in.	1	1875
16¼ in.	7 ft.	46 in.	1⅜ in.	11⅞ in.	2¼ in.	1	1955
16¼ in.	8 ft.	58 in.	1⅜ in.	11⅞ in.	2¼ in.	1	2035
16¼ in.	10 ft.	82 in.	1⅜ in.	11⅞ in.	2¼ in.	1	2195
16¼ in.	12 ft.	106 in.	1⅜ in.	11⅞ in.	2¼ in.	1	2355
18-inch Lathes—Quick Change and Standard Change Gear							
18¼ in.	6 ft.	29½ in.	1⅞ in.	12⅝ in.	2½ in.	2	2440
18¼ in.	7 ft.	41½ in.	1⅞ in.	12⅝ in.	2½ in.	2	2540
18¼ in.	8 ft.	53½ in.	1⅞ in.	12⅝ in.	2½ in.	2	2640
18¼ in.	10 ft.	77½ in.	1⅞ in.	12⅝ in.	2½ in.	2	2840
18¼ in.	12 ft.	101½ in.	1⅞ in.	12⅝ in.	2½ in.	2	3140
18¼ in.	14 ft.	125½ in.	1⅞ in.	12⅝ in.	2½ in.	2	3540
21-inch Lathes—Quick Change and Standard Change Gear							
21¼ in.	10 ft.	72 in.	1½ in.	15⅞ in.	3 in.	3	3940
21¼ in.	12 ft.	96 in.	1½ in.	15⅞ in.	3 in.	3	4300
24-inch Lathes—Quick Change and Standard Change Gear							
24¼ in.	10 ft.	67 in.	1¾ in.	17⅞ in.	3½ in.	3	4740
24¼ in.	12 ft.	91 in.	1¾ in.	17⅞ in.	3½ in.	3	5140

Note: For Descriptions see pages 20 and 129.

AUTO MECHANIC'S SERVICE BOOK NO. 66

For the Auto Machinist and Apprentice

Price 25c Postpaid

Service Book No. 66 contains 120 halftones illustrating and describing the modern methods of machining the important parts of the automobile motor in the Auto Service Station, Garage and Electrical Shop.

This Service Book is recommended by the automobile manufacturers for use in their Service Stations throughout the world, to guide the auto mechanic in servicing the motor with accuracy, precision, speed and at the lowest cost, which after all is the real meaning of "service."



The Principal Jobs Described in Service Book No. 66

Finishing Pistons
 Truing Commutators
 Testing Armatures
 Refacing Valves
 Testing Valves
 Making Bushings
 Machining Fly Wheels
 Machining Axles and Drive Shafts
 Testing Crankshafts

Reboring Cylinders
 Regrinding Cylinders
 Boring Connecting Rods
 Truing Brake Drums
 Grinding Reamers
 Cutting Screw Threads
 Making Radio Parts
 Hundreds of other Jobs

BELOW—A HALF PAGE FROM SERVICE BOOK NO. 66

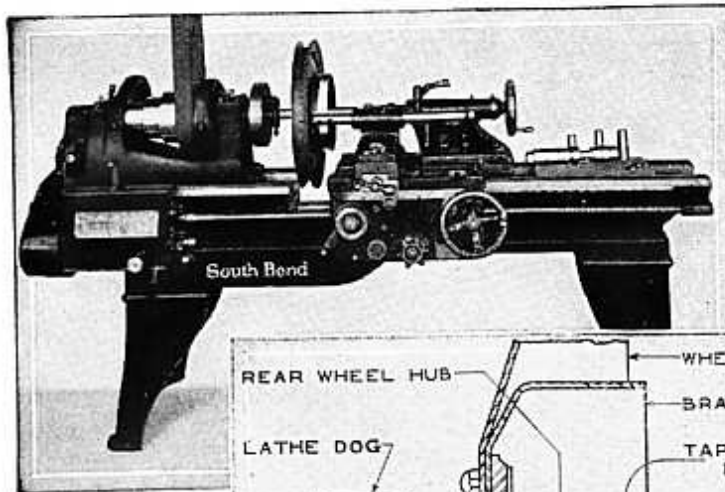

Gap Lathe with Double Bridge Truing a Brake Drum

Left—The Rear Wheel of an Automobile mounted on a Special Arbor between Centers in the Lathe for the purpose of truing the Brake Drum

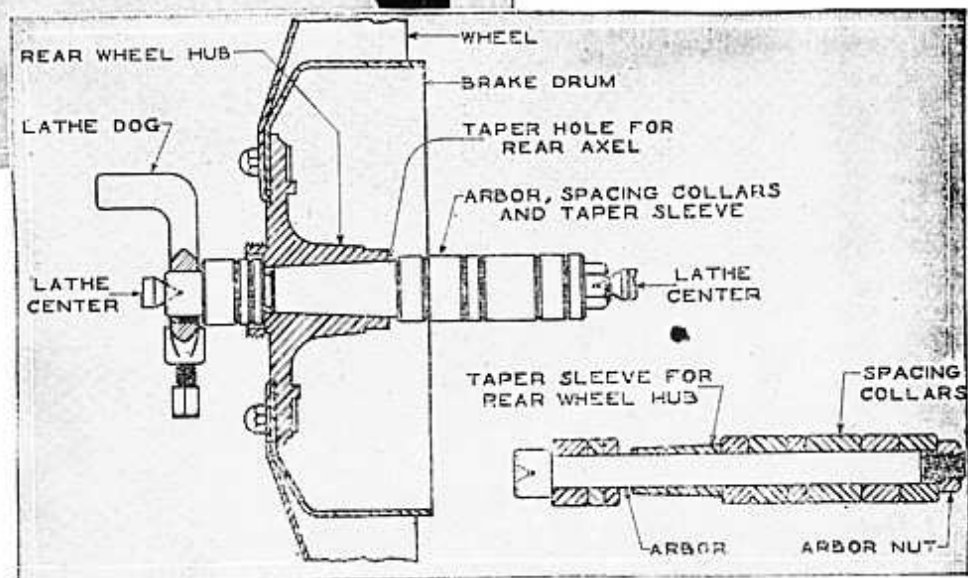

Right — The drawing shows the application of a Special Hub Arbor for holding and driving the rear auto wheel of all makes and sizes in the lathe

THREE PRACTICAL SERVICE JOBS DESCRIBED IN AUTO MECHANIC'S SERVICE BOOK NO. 66

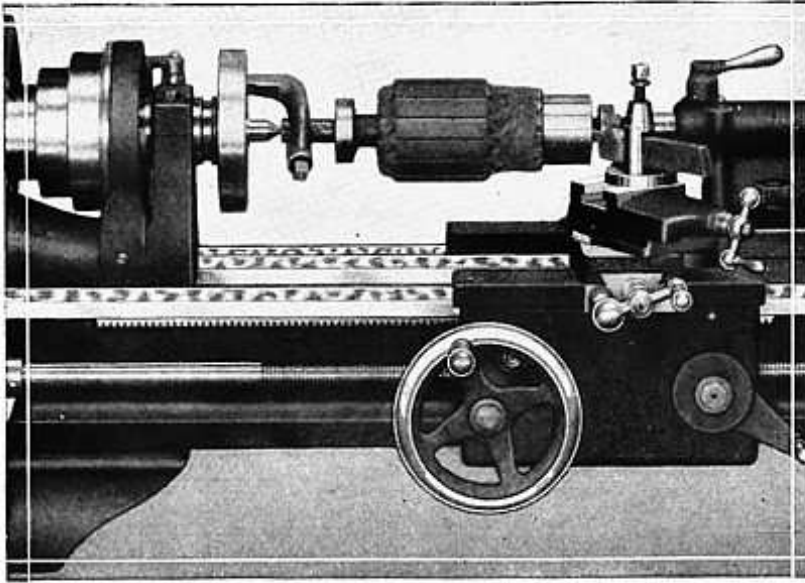

Armature Truing in the Lathe

The Lathe is the practical tool for truing armature commutators and for general machine work in the electrical service station. Machining the commutator smooth and true is a precision job and must be done on a screw cutting Lathe with power feed, if satisfactory results are to be obtained.

Finish Turning Semi- machined Pistons in the Lathe

The correct way to machine semi-machined pistons is to turn them to finished size in the Lathe instead of grinding, because turning is four times faster and produces just as good a job. The Lathe can be used for hundreds of other jobs.

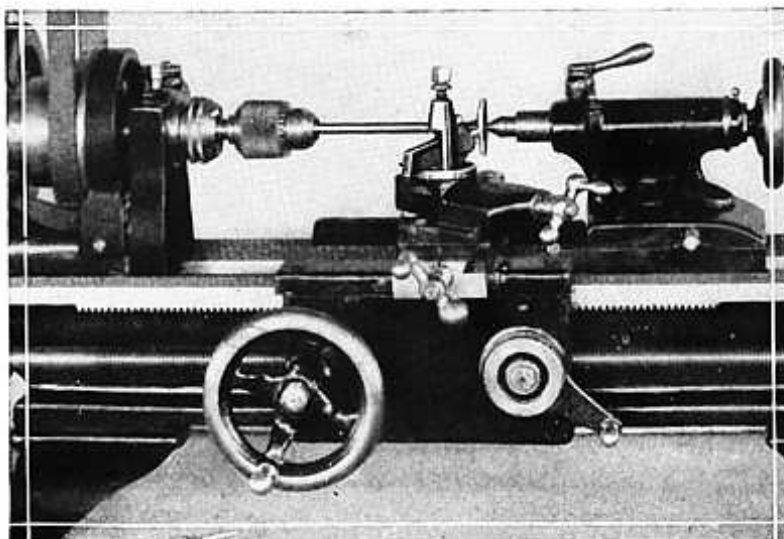
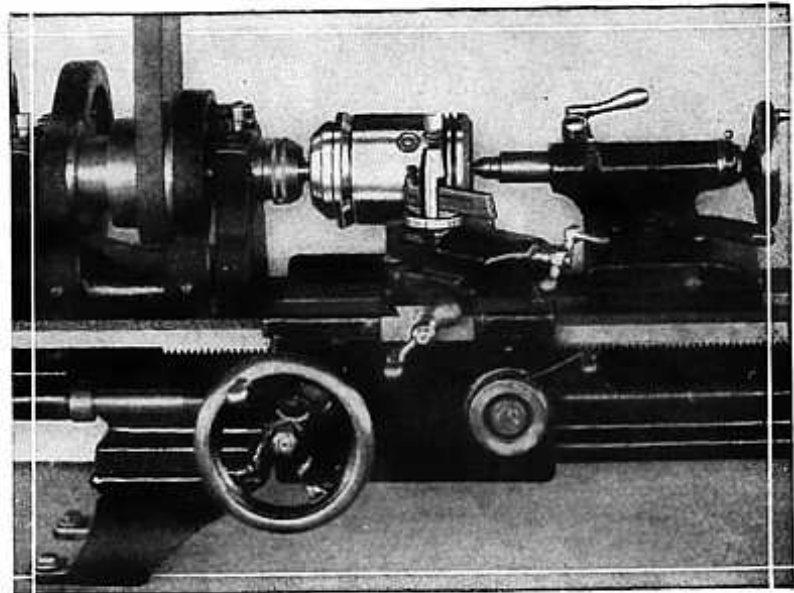

Refacing Valves in the Lathe

The Screw Cutting Lathe is the ideal tool for refacing Valves by turning, because the Compound Rest of the Lathe can be set to the exact angle desired. The Valve can be refaced by turning four times faster than grinding and yet produce a better job.

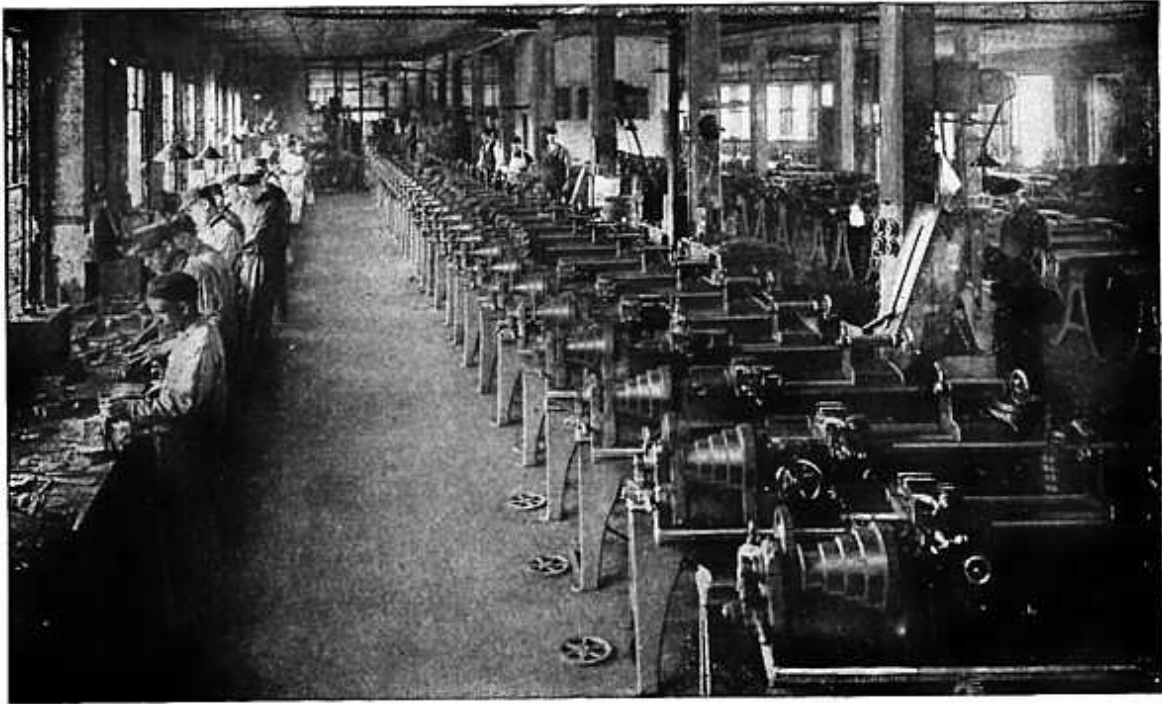

ASSEMBLING LATHES IN GROUPS OF TWENTY-FIVE

The illustration shows an assembly room in the factory of the South Bend Lathe Works where lathes are assembled and tested in groups of twenty-five. Then each lathe is set under belt, operated and tested before leaving the factory.

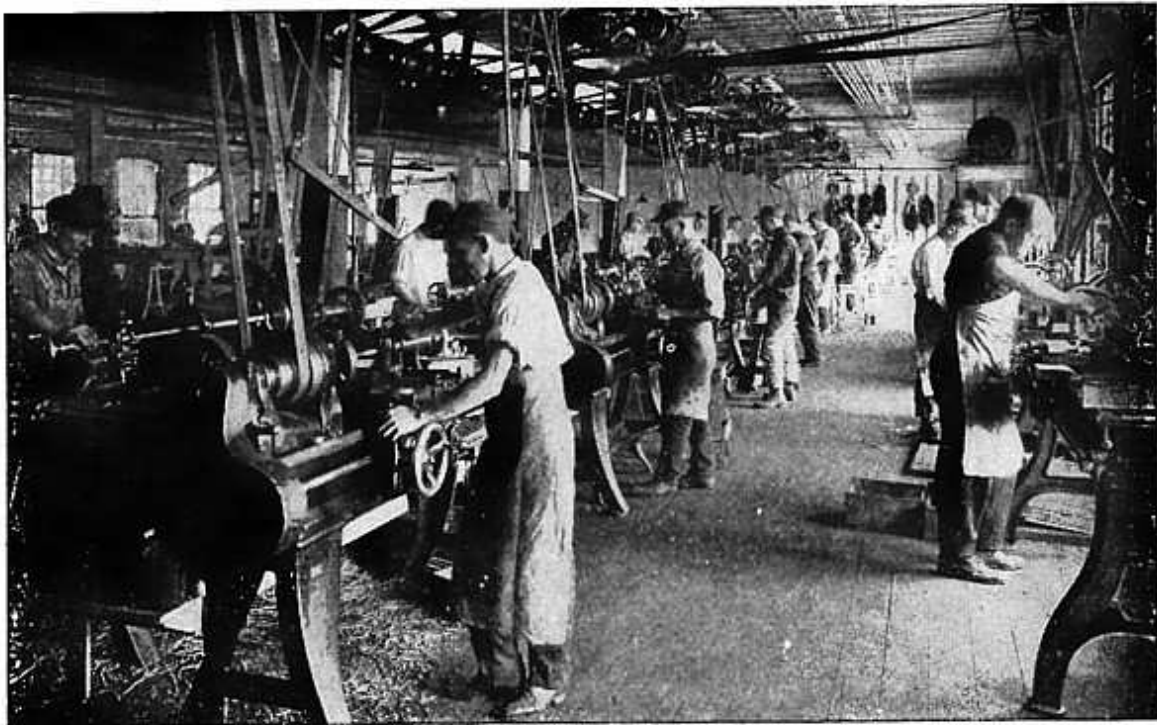

A GROUP OF SIXTEEN LATHES IN OPERATION IN A FACTORY

The illustration above shows a group of sixteen Lathes that are being used in a manufacturing plant, producing metal parts. These Lathes are all driven by overhead countershafts, which are driven from an overhead line shaft. One 15 H.P. Motor supplies sufficient power to drive all of these Lathes. The Motor can be seen on the side wall.

INDEX

	PAGE
Acme Threads.....	100
Auto Repair Work, Examples, etc.....	141
Auto Mechanic's Service Book.....	140
Backing Off Attachment.....	120
Bench Lathe.....	133
Boring in the Lathe.....	113
Brown & Sharpe Tapers.....	79
Caliper in Measuring.....	31
Catalog on Lathes, Attachments, etc.....	138
Centering Work.....	35-36
Chucks for Lathes.....	61
Chuck Plate Threading and Fitting.....	63
Chucking Work.....	66
Collets, Spring.....	128
Countersinking Center Holes.....	38-39
Compound Rest.....	80
Countershaft, Speed of.....	11
Cutting Screw Threads.....	87
Cutting Speed for Different Metals.....	47
Decimal Equivalents.....	119
Don'ts for Machinists.....	125
Draw-in Collet Chuck Attachment.....	128
Drill Grinding Gauge.....	114
Emery Wheel Speeds.....	117
Erection and Foundation Plans.....	136-137
Face Plate Work.....	69-70
Fitting and Testing Screw Threads.....	97
Follower Rest and Center Rest.....	59
Gap Bed Lathe.....	132
Gearing a Lathe for Cutting Screw Threads.....	99
Gears, Information on.....	124
Grinding and Setting the Threading Tool.....	97
Grinding in the Lathe.....	116-118
Index Plates for Quick Change and Standard Change Gear Lathes.....	92-93
Keyways, Standard Sizes.....	108
Knurling in the Lathe.....	52
Lacing a Belt.....	14
Lathe, Automatic Feeds.....	23
Lathe Centers.....	44
Lathe Dogs for Driving Work.....	41
Lathe Equipment.....	21
Lathe, Quick Change Gear.....	20
Lathe, Standard Change Gear.....	129

INDEX—Continued

	PAGE
Lathe Specifications.....	139
Lathe Tools.....	25-30
Machine Shop Course.....	122-123
Machining in the Chuck.....	61
Machining Work on a Mandrel.....	53
Measuring Screw Threads.....	89
Measuring with Calipers.....	31
Mechanism of Lathe Apron.....	24
Metric Linear Measure.....	119
Metric Threads.....	104
Milling and Keyway Cutting Attachments.....	105-106
Milling Cutters for Keyways.....	107
Morse Tapers.....	76
Motor Drive Lathes, Silent Chain.....	130-131
Motor Drive Lathes, Bench.....	134-135
Mounting Lathe Centers in Spindles.....	42
Mounting Work in a Center Rest.....	58
Oiling the Lathe and Countershaft.....	16-17
Pitch and Lead of Screw Threads.....	103
Quick Change Gear Box for Turning Feeds.....	94
Reaming and Tapping.....	115
Screw Thread Cutting.....	86-104
Screw Thread Pitches—U.S.S., A.S.M.E., S.A.E.....	88
Setting Thread Tool.....	90
Simple Geared Lathe for Thread Cutting.....	91
Size of Lathe Chuck for a Lathe.....	62
Speed and Size of Pulleys, Rules for Calculating.....	12
Spindle Speeds of Lathes.....	48
Standard Keyways for Pulley and Shafts.....	108
Table of Decimal Equivalents.....	119
Tap Drill Sizes.....	88
Taper Attachment.....	82
Taper Turning and Boring.....	75
Test Dial Indicator, Factory Test Card.....	72-74
Testing Alignment of Centers.....	50
Testing and Truing Lathe Centers.....	81
Thread Cutting.....	86-104
Thread Dial.....	98
Turret Work.....	109
Tool Room Lathe.....	126-127
Transposing Gears for Metric Threads.....	104
Turning Taper with Taper Attachment.....	83-84
Turrets, Turnstile, Tool Post, Hand Lever, etc.....	111
U. S. Standard Tool Gauge for Screw Threads.....	89
Woodruff Keyway.....	103
Wood Turning on Lathes.....	85

How to Become a Machinist

1. Keep your cutting tools sharp.
2. Look at your drawing carefully before starting your job.
3. Be sure your machine is set up right before starting the work.
4. Take your measurements accurately.
5. Keep your machine well oiled, clean and neat. Personal neatness will give you personality.
6. Take an interest in your job; don't feel that you are forced to work.
7. Learn the fundamentals of mechanical drawing.
8. Keep your belts tight and free from oil.
9. Take as heavy a cut as the machine and cutting tool will stand until you are near the finished size; then finish carefully and accurately.
10. Try to understand the mechanism of the machine you are operating.
11. Hold yourself responsible for the job you are working on.
12. Keep your eyes on the man ahead of you: you may be called on to take his place some day.
13. Have a place for everything, and keep everything in its place.
14. Read one or two of the technical magazines relating to your line of work.
15. If a boy learns a trade properly he becomes a first-class mechanic, but if he has ability he need not stop at that. Henry Ford, George Westinghouse and others got their start because they were mechanics.
16. If you have spoiled a job, admit your carelessness to your foreman, and don't offer any excuses.

SOUTH BEND LATHE WORKS

NOTE: A Blue Print (12"x18") of the above sixteen suggestions, suitable for wall display, will be mailed upon the receipt of 10c to cover cost of mailing.

SOUTH BEND LATHE WORKS

435 E. Madison Street

SOUTH BEND, INDIANA, U. S. A.